

Tork Craft™

Tools for every job

2020/2021

Edition

www.torkcraft.com



Index

Abrasives	76 - 87	Leather Hole Punch	137
Allen Keys	72 - 73	Lighting	114 - 115
Ammunition Cases	106	Lock Mortiser	125
Annular Cutters	36	MAD-BIT Titanium	46
Auger Bits	48 - 49	Magnetic Core Drills	35
Axes	143	Magnetic Tools	132, 144
Backpacks	106	Measuring	95 - 96, 99, 100
Bicycle Repair Stand & Bicycle Storage	116	Mini Rotary Tool & Accessories	117 - 120
Biscuit Jointing / Dowelling	128	Mortar & Grout Gun	139
Caulking Guns / Caulking Tools	139	Mortice Chisels	126
Centre Punches	127	NIBBLER Sheet Metal Cutter	97
Chucks	54	Oscillating Multi-function Tool & Blades	13 - 14
Circular Saw Blades	1 - 7	Paint Markers	98
Clamps / Vices	129 - 131	Paint Mixers	137
Clothing / Caps / Shoes	150 - 152	Palm Wrench	137
Cooler Boxes	101	Pipe Cutters	150
Countersinks	51	Pipe Wrenches / Bolt Cutters	144
Cutting & Grinding Discs	75	Planer Blades	11
Decking Tools	59	Pliers	141 - 143
Diamond Blades / Diamond Polishing	20 - 25	Plug Cutters	49
Diamond Tools	50	Polishing & Sanding	88 - 94
Display Stands	153 - 154	Power Tools Cordless	135 - 136
Drill Bits	41 - 47	Precision Tools	70
Drill Saws Titanium	53	Riveters	74
Dustmasks	110	Rotary Burrs, Files & Rasps	52 - 53
Ear Clamps	15	Router Bits / Routing	16 - 19
Ear Plugs	109	Safety Eyewear	110
Educational Wooden Toys	155	Screwdriving	55 - 71
Electric Engraver	118	Screw Extractors / Thread Lock	40
Foam Guns	139	Scroll Saw Blades	12
Forstner Bits	48	Spade Bits	45 - 46
Glass & Tile Drill Bits	50	Spanners - Combination & Shifting	140 - 141
Gloves	108	Standing Desks	134
Glue Guns & Glue Sticks Hot Melt	98	Staple Guns	137
Grease Guns	138	Step Drills	51
Grinding Wheels	80	Storage Cases	102 - 106
Hacksaws	149	Taps & Dies	37 - 38
Hammers	145	Thread Repair Kits	39
Hand Saws	146	Tool Belts, Bags, Pouches & Knee Pads	107
Hard Storage Cases / Micro Cases	102 - 106	Tool Boxes & Trolleys	147 - 148
Hole Saws	26 - 34	Torches & Batteries	111 - 113
Hollow Core Bits	32	Torque Wrenches Digital & Mechanical	148
Hose Clamps	15	Vice Jaws	144
Impact Sockets	121 - 124	Wire Brushes	77 - 79
Jigsaw Blades	8 - 11	Wood Chisels	126 - 127
Knives & Multi Tools	109	Work Station 4-in-1	133
Laser Distance Meters	99	Wood Storage Racks	101
Letter & Number Punches	97		



CIRCULAR SAW BLADE PRODUCT KNOWLEDGE

Features and Information

Our product selection consists of high-quality circular saw blades available for use in portable, cordless and stationary saws. Saw blades are available in configurations for most applications, from general purpose blades to highly specialized designs. Everything depends on how much blade you want, and that's often a question of construction material and amount of use.

Circular Saw Blade and Dado Terms:

Below is a list of Circular Saw Blade terms and illustrations to assist you in selecting the right blade for the right job:

Anti-kick Saw Blades: A particular Circular Saw Blade's (CSB) shoulder design that is engineered to improve the ease of cut and reduce the effect of the saw blade kicking back due to overfeeding.

Arbor: The saw motor shaft that rotates the saw blade. Often referred to as the mandrel.

Bore: The arbor by which the saw blade is mounted on the saw. Available in various sizes. Bore size on the blade.

Bevel: Angles on a carbide tooth CSB. Teeth can have a single bevel, two bevel or no bevel at all. Types of bevels can alternate from tooth to tooth on a given blade. The bevel is what gives the blade its specific cutting pattern.

Chipper: A cutting tool that is placed between the outside blades of a dado set to adjust the width of the cut.

Chipping: The condition caused when the saw blade lifts and tears the wood fibers as it exits the material. This causes the edges to be ragged.

Coating: Specially formulated coatings that stay slick. Coating a blade reduces heat in 2 ways. It minimises friction and binding and resists pitch and gum buildup.

Combination Saw Blade: Saw blades used for both ripping (cutting with the grain of the wood) and crosscutting (cutting across the grain).

Crosscut: To cut or saw against/across the grain of the wood.

Cutter: Outside blades used in dado blades.

Expansion slots: The spaces that allow a blade to expand as it heats up during cutting. It eliminates warpage by cooling the blade.

Ferrous: Metals or materials of or containing iron.

Nonferrous: Materials or metals not of or containing iron, such as aluminium, copper, brass and lead.

Finishing Saw Blade: A saw blade with a higher tooth count to provide smoother cuts. Typically refers to 7 1/4 inch blades with more than 40 teeth and 10 inch blades with more than 60 teeth.

Framing Saw Blade: Carbide tipped saw blades used to make fast cuts in all types of wood (the fastest cutting is achieved with lower tooth count saw blades).

General Purpose Saw Blades: Lower tooth count saw blades. Used primarily for fast cross cutting and ripping.

Gullet: The space between teeth that clears the work piece or chips after the cut.

Grind: There are many types of tooth grinds, a few of the basic ones are:



Flat Top Grind (FTG) Best for ripping



Alternate Top Bevel (ATB) for crosscutting, cutoff and trimming



Triple Chip Grind (TCG) perfect for hard abrasive materials like non-ferrous metals, hard woods and plastics



Tri-Grind (TRI) Combination grind

Hollow Ground: A concave bevel edge on a tool.

Hook angle: The "attack angle" of the teeth. Harder, more brittle materials need a shallower angle to ease pressure against the materials and reduce chip out. Softer materials require a sharper angle to reduce chip out.

Miter: The process of cutting material for an equal angle joint.

Plate: The steel body of the carbide blade on which the teeth are welded.

Plane: In woodworking, to make a surface smooth or even.

Rabbit: An open-ended cut made along the edge of a work piece that receives or interlocks with another piece to form a joint.

Ripping: The process of sawing a board in the direction of the grain of the board.

Run out: The amount of left to right movement a saw blade makes during operation. Often referred to as wobble or warp.

Stiffening Collar: A flat collar that mounts on the saws arbor directly next to the blade. They are used to make more accurate cuts and dampen the sound the saw generates.

Shim: A thin, often tapered piece of material such as metal or wood used to fill in space between things. In dado operations, a round disk used to make a wider cut.

Tear-out: A condition in which the saw blade tears out the grain of a work piece.

Tempered: To bring the steel plate of a saw blade to a desired hardness by reheating and cooling.

Kerf: This is the width of the cut, including the steel plate thickness plus any overhang on a carbide blade.

Thin kerf saw blades: A saw blade with a reduced kerf, <2.2mm or cut width.

TCT circular saw blades general purpose, contractor quality for cutting wood & plastics.
( ATB) Positive



TCP



Wood



Plastic

Part No.	Diameter	Bore / Bushings	No of Teeth	Kerf	RPM
TCP10008	100mm	22.23mm	8T	4.0mm	16000
TCP15040	150mm	20/16mm	40T	2.3mm	12000
TCP16020	160mm	20/16mm	20T	2.3mm	11500
TCP16040	160mm	20/16mm	40T	2.3mm	11500
TCP16060	160mm	20/16mm	60T	2.3mm	11500
TCP16524-20	165mm	20/16mm	24T	2.3mm	11000
TCP17024	170mm	20/16mm	24T	2.3mm	9500
TCP17040	170mm	20/16mm	40T	2.3mm	9500
TCP17060	170mm	20/16mm	60T	2.3mm	9500
TCP18024	180mm	20/16mm	24T	2.3mm	9000
TCP18024-30	180mm	30/20/16mm	24T	2.3mm	9000
TCP18040	180mm	20/16mm	40T	2.3mm	9000
TCP18040-30	180mm	30/20/16mm	40T	2.3mm	9000
TCP18060	180mm	20/16mm	60T	2.3mm	9000
TCP18060-30	180mm	30/20/16	60T	2.3mm	9000
TCP18524-16	185mm	16mm	24T	2.3mm	9000
TCP18524-20	185mm	20/16mm	24T	2.3mm	9000
TCP18524-30	185mm	30/25.4/20/16mm	24T	2.3mm	9000
TCP18540	185mm	20/16mm	40T	2.3mm	9000
TCP18540-16	185mm	16mm	40T	2.3mm	9000
TCP18540-30	185mm	30/25.4/20/16mm	40T	2.3mm	9000
TCP18560	185mm	20/16mm	60T	2.3mm	9000
TCP18560-30	185mm	30/25.4/20/16mm	60T	2.3mm	9000
TCP19024	190mm	30/20/16mm	24T	2.3mm	8500
TCP19040-16	190mm	16mm	40T	2.3mm	8500
TCP19040-30	190mm	30/20/16mm	40T	2.3mm	8500
TCP19060	190mm	30/25.4/20/16mm	60T	2.3mm	8500
TCP19072	190mm	30/20/16mm	72T	2.3mm	8500
TCP20024	200mm	30/25.4/20/16mm	24T	2.8mm	8000
TCP20040	200mm	30/20/16mm	40T	2.8mm	8000
TCP20060	200mm	30/20/16mm	60T	2.8mm	8000
TCP21024	210mm	30/20/16/25.4mm	24T	2.8mm	7800
TCP21040-16	210mm	16mm	40T	2.8mm	7800
TCP21040-30	210mm	30/20/16mm	40T	2.8mm	7800
TCP21060	210mm	30/20/16/25.4mm	60T	2.8mm	7800
TCP23024	230mm	30/20/16/25.4mm	24T	3.0mm	7000
TCP23024-16	230mm	16mm	24T	3.0mm	7000
TCP23040	230mm	30/25.4/20/16mm	40T	3.0mm	7000
TCP23040-16	230mm	16mm	40T	3.0mm	7000
TCP23060-16	230mm	16mm	60T	3.0mm	7000
TCP23060-30	230mm	30/20/16mm	60T	3.0mm	7000
TCP23524-16	235mm	16mm	24T	3.0mm	7000
TCP23540-16	235mm	16mm	40T	3.0mm	7000
TCP25024	250mm	30/20/16/25.4mm	24T	3.0mm	6000
TCP25040	250mm	30/25.4/20/16mm	40T	3.0mm	6000
TCP25040-16	250mm	16mm	40T	3.0mm	6000
TCP25060-16	250mm	16mm	60T	3.0mm	6000
TCP25060-30	250mm	30/20/16mm	60T	3.0mm	6000
TCP25080	250mm	30/20/16mm	80T	2.8mm	6000
TCP26024-30	260mm	30/25.4/20/16mm	24T	3.0mm	5800
TCP26040-30	260mm	30/25.4/20/16mm	40T	3.0mm	5800
TCP30024	300mm	30/20/16mm	24T	3.2mm	5000
TCP30040	300mm	30/20/16mm	40T	3.2mm	5000
TCP30060	300mm	30/25.4/20/16mm	60T	3.2mm	5000
TCP30080	300mm	30/25.4/20/16mm	80T	3.2mm	5000
TCP30096	300mm	30/20/16mm	96T	3.2mm	5000
TCP31548	315mm	30/20/16mm	48T	3.2mm	4800
TCP31560	315mm	30/20/16mm	60T	3.2mm	4800
TCP35030	350mm	30/20/16mm	30T	3.4mm	4800
TCP35060	350mm	30mm	60T	3.4mm	4800
TCP35096	350mm	30/20/16mm	96T	3.4mm	4800
TCP400100	400mm	30/25.4/20/16mm	100T	3.4mm	3300
TCP40030	400mm	30/20/16/25.4mm	30T	3.4mm	3300
TCP450120	450mm	30/25.4/20/16mm	120T	3.8mm	3300
TCP45036	450mm	30/20/16/25.4mm	36T	3.8mm	3300
TCP500120	500mm	30/20/16mm	120T	4.0mm	3300
TCP60036	600mm	40/30/25.4/20/16	36T	4.0mm	2500
TCP60060	600mm	40/30/25.4/20/16	60T	4.0mm	2500
TCP60072	600mm	40/30/25.4/20/16	72T	4.0mm	2500

CONTRACTOR

TCP - TCG

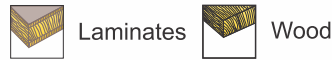

TCT circular saw blades for wood and laminates. Triple chip grind (TCG). Positive.



CONTRACTOR

Part No.	Diameter	Bore / Bushings	No of Teeth	Kerf	RPM
TCP25080TCG	250mm	30/25.4/20/16mm	80T	3.0mm	6000
TCP30096TCG	300mm	30/25.4/20/16mm	96T	3.2mm	5000



TCP - AL



TCT circular saw blades for aluminium and non-ferrous metal cutting. Triple chip grind (TCG). Negative.



Note:
Non-ferrous metal must be clamped down before cutting

Part No.	Diameter	Bore / Bushings	No of Teeth	Kerf	RPM
TCP16060AL	160mm	20/16mm	60T	2.3mm	11500
TCP17060AL	170mm	20/16mm	60T	2.3mm	9500
TCP18560AL	185mm	20/16mm	60T	2.3mm	9000
TCP18560AL-30	185mm	30mm	60T	2.3mm	9000
TCP19060AL	190mm	30/20/16mm	60T	2.3mm	8500
TCP20060AL	200mm	30/20/16mm	60T	2.6mm	8000
TCP21060AL	210mm	30/16mm	60T	2.6mm	7800
TCP23060AL	230mm	30/16mm	60T	2.8mm	7500
TCP250100AL	250mm	30/25.4/20/16mm	100T	3.0mm	6000
TCP25080AL	250mm	30/25.4/20/16mm	80T	3.0mm	6000
TCP30096AL	300mm	30/25.4/20/16mm	96T	3.2mm	5500
TCP31596AL	315mm	30/25.4/20/16mm	96T	3.2mm	4800
TCP350100AL	350mm	30/25.4/16mm	100T	3.4mm	4500

CONTRACTOR



TCE



TCT circular saw blades. Professional quality, Euro style. For cutting wood & plastics. Alternate bevel grind teeth (ATB). Positive. Heavy body and large tips.



Note:
TCE blades have large teeth that can be resharpened more often thereby lengthening the life of the blade

Part No.	Diameter	Bore / Bushings	No of Teeth	Kerf	RPM
TCE16048	160mm	20/16mm	48T	2.8mm	9500
TCE16060	160mm	20/16mm	60T	2.8mm	9500
TCE18524-20	185mm	20/16mm	24T	2.8mm	9000
TCE18548	185mm	20/16mm	48T	2.8mm	9000
TCE19048	190mm	20/16mm	48T	2.8mm	8500
TCE23024-30	230mm	30/25.4/20/16mm	24T	2.8mm	7000
TCE23048	230mm	30/25.4/20/16mm	48T	3.0mm	7000
TCE25024-30	250mm	30/25.4/20/16mm	24T	2.8mm	6900
TCE25048	250mm	30/25.4/20/16mm	48T	2.8mm	6900
TCE25460	254mm	30/25.4/20/16mm	60T	3.0mm	6900
TCE30072	300mm	30/16mm	72T	3.0mm	5500
TCE30528-30	305mm	30/25.4/20/16mm	28T	3.2mm	5500
TCE30572-30	305mm	30/1/20/16mm	72T	3.2mm	5500
TCE30596-30	305mm	30/25.4/20/16mm	96T	3.2mm	5500

INDUSTRIAL



TCE - AL



Professional quality euro style TCT circular saw blades for aluminium and non-ferrous metal cutting. Triple chip grind (TCG). Negative.

Part No.	Diameter	Bore / Bushings	No of Teeth	Kerf	RPM
TCE16060AL	160mm	20/16mm	60T	2.8mm	9500
TCE23060AL	230mm	30/25.4/20/16mm	60T	3.0mm	7000
TCE25080AL	250mm	30/25.4/20/16mm	80T	3.0mm	6000
TCE305100AL	305mm	30/20mm	100T	3.2mm	5500

INDUSTRIAL



TCD



Wood



Plastic

TCT circular saw blades general purpose, for cutting wood, plastics. Alternate bevel grind teeth. (ATB). Positive.



Part No.	Diameter	Bore / Bushings	No of Teeth	Kerf	RPM
TCD12516-16	125mm	16/13mm	16T	2.0mm	12000
TCD12516-20	125mm	20/13mm	16T	2.0mm	12000
TCD13016	130mm	16/13mm	16T	2.2mm	12000
TCD13030	130mm	16/13mm	30T	2.2mm	12000
TCD14016	140mm	20/16/13mm	16T	2.2mm	12000
TCD14030	140mm	20/16/13mm	30T	2.2mm	12000
TCD15024	150mm	20/16mm	24T	2.2mm	12000
TCD15040	150mm	20/16mm	40T	2.2mm	12000
TCD16020	160mm	20/16mm	20T	2.2mm	11500
TCD16030	160mm	20/16mm	30T	2.2mm	11500
TCD16040	160mm	20/16mm	40T	2.2mm	11500
TCD16060	160mm	20/16mm	60T	2.2mm	11500
TCD16524-20	165mm	20/16mm	24T	2.2mm	11000
TCD16540-20	165mm	20/16mm	40T	2.2mm	11000
TCD17024	170mm	20/16mm	24T	2.2mm	9500
TCD17040	170mm	20/16mm	40T	2.2mm	9500
TCD17060	170mm	20/16mm	60T	2.2mm	9500
TCD18024	180mm	30/20/16mm	24T	2.2mm	9000
TCD18040	180mm	30/20/16mm	40T	2.2mm	9000
TCD18060	180mm	30/20/16mm	60T	2.2mm	9000
TCD18060-30	180mm	30/20/16mm	60T	2.2mm	9000
TCD18524	185mm	20/16mm	24T	2.2mm	9000
TCD18524-30	185mm	30/25.4/20/16mm	24T	2.2mm	9000
TCD18540-16	185mm	16mm	40T	2.2mm	9000
TCD18540-20	185mm	20/16mm	40T	2.2mm	9000
TCD18540-30	185mm	30/25.4/20/16	40T	2.2mm	9000
TCD18560	185mm	20/16mm	60T	2.2mm	9000
TCD18560-16	185mm	16mm	60T	2.2mm	9000
TCD19040-16	190mm	16mm	40T	2.2mm	8500
TCD19040-30	190mm	30/20/16mm	40T	2.2mm	8500
TCD19060	190mm	30/20mm	60T	2.2mm	8500
TCD19072	190mm	30/20/16mm	72T	2.2mm	8500
TCD20024	200mm	30/20/16mm	24T	2.2mm	8000
TCD21024-16	210mm	16mm	24T	2.2mm	7800
TCD21024-30	210mm	30/25.4/20/16mm	24T	2.2mm	7800
TCD21040	210mm	30/25.4/20/16mm	40T	2.2mm	7800
TCD21040-16	210mm	16mm	40T	2.2mm	7800
TCD21060	210mm	30/25.4/20/16mm	60T	2.2mm	7800
TCD23024	230mm	30/25.4/20/16mm	24T	2.6mm	7000
TCD23024-16	230mm	16mm	24T	2.6mm	7000
TCD23040	230mm	30/25.4/20/16mm	40T	2.6mm	7000
TCD23060	230mm	30/25.4/20mm	60T	2.6mm	7000
TCD23524-16	235mm	16mm	24T	2.6mm	7000
TCD23524-30	235mm	30/20/16mm	24T	2.6mm	7000
TCD23540-16	235mm	16mm	40T	2.6mm	7000
TCD23540-30	235mm	20/16mm	40T	2.6mm	7000
TCD25024	250mm	30/16mm	24T	2.8mm	6000
TCD25040-16	250mm	16mm	40T	2.8mm	6000
TCD25040-30	250mm	30/25.4/20/16mm	40T	2.8mm	6000
TCD25080	250mm	30/25.4/20mm	80T	2.8mm	6000

DADO Sets

Cuts grooves from 3.4mm to 25.4mm

Part No. TC324311

DADO Set 203mm/8" in Wooden Case, Bore 16mm

- » 2 x 203mm/8" x 24T Outside blades
- » 4 x 4.1mm Twin tooth chippers
- » 1 x 2.5mm Twin tooth chippers
- » Dado Shim Set

Part No. TC324312

DADO Set 150mm/6" in Aluminium Case, Bore 16mm

- » 2 x 150mm/6" x 24T Outside blades
- » 4 x 4.1mm Twin tooth chippers
- » 1 x 2.5mm Twin tooth chippers
- » Dado Shim Set



TCTK



Wood



Plastic

Thin kerf blades. Thinner blades put less drag on the saw motors and also reduce wastage during cutting. (ATB).

SPECIALISED Thin Kerf

Part No.	Diameter	Bore / Bushings	No of Teeth	Kerf	RPM
TCTK18440	185mm	20/16mm	40T	2.2mm	9000
TCTK18460	185mm	20/16mm	60T	2.2mm	9000
TCTK25060	250mm	30/16mm	60T	2.0mm	5500

INDUSTRIAL



TCNC



Wood with Nails

Special nail cutting blade. For use in old lumber with embedded nails or when remodeling old trusses etc.

SPECIALISED Nail Cutting

Part No.	Diameter	Bore / Bushings	No of Teeth	Kerf	RPM
TCNC18514	185mm	20/16mm	14T		8000

INDUSTRIAL



TCNF



Wood



Laminates

Low noise blade. Great for closed workshop environments. Precision laser cut wave for accurate work. (ATB).

SPECIALISED Low Noise

Part No.	Diameter	Bore / Bushings	No of Teeth	Kerf	RPM
TCNF18540	185mm	20/16mm	40T	2.2mm	8000
TCNF25448	254mm	30/25.4/20/16mm	48T	2.0mm	5500

INDUSTRIAL



TCMB



Wood



Laminates

Anti-kick back blades specially designed for hand held circular power saws. "J" slots help reduce noise and allow for heat expansion and body vents help keep the blade cool. (ATB).

SPECIALISED Thin Kerf Anti Kickback

Part No.	Diameter	Bore / Bushings	No of Teeth	Kerf	RPM
TCMB18524	185mm	20/16mm	24T	2.0mm	8000
TCMB18540	185mm	20/16mm	40T	2.0mm	8000

INDUSTRIAL



Anti-kick back blades specially designed for hand held circular power saws



TCS



Mild Steel

TCT circular saw blades for cutting ferrous metals. Replacement blades for machine specific tools, for use on machines designed for cutting ferrous metal.

SPECIALISED Steel Cutting

Part No.	Diameter	Bore / Bushings	No of Teeth	Kerf	RPM
TCS18532-20	185mm	20/16mm	32T	2.2mm	8500
TCS18550	185mm	20/16mm	50T	3.2mm	3600
TCS18568	185mm	20/16mm	68T	2.0mm	3600
TCS30080	300mm	25.4mm	80T	2.4mm	2500
TCS30080-30	300mm	30mm	80T	2.4mm	2500
TCS30560	305mm	30mm	60T	2.8mm	2500
TCS30580	305mm	30mm	80T	2.8mm	2500

CONTRACTOR





TCPR - LM



Double-sided laminates

TCT circular saw blades for cutting double-sided laminated board and medium density fibreboard. (ATB) Positive.

Part No.	Diameter	Bore / Bushings	No of Teeth	Kerf	RPM
TCPR16048LM	160mm	20/16mm	48T	2.4mm	9500
TCPR18548LM	185mm	20/16mm	48T	2.4mm	8500
TCPR19048LM	190mm	30/20/16mm	48T	2.8mm	7500
TCPR23080LM	230mm	30/25.4/16mm	80T	3.0mm	6600
TCPR25080LM	250mm	30/25.4/20/16mm	80T	3.2mm	6000
TCPR30096LM	300mm	30/25.4/20mm	96T	3.2mm	5000

INDUSTRIAL



TCPR - AL TCG



Alum

TCT circular saw blades for cutting aluminium. Triple chip grind (TCG) Negative.

Part No.	Diameter	Bore / Bushings	No of Teeth	Kerf	RPM
TCPR16056AL	160mm	20/16mm	56T	2.4mm	9500
TCPR25080AL	250mm	30mm	80T	3.2mm	6000
TCPR305100AL	305mm	30mm	100T	3.2mm	5000

INDUSTRIAL



TCPR - SC



Wood

TCT scoring saw blades.

Part No.	Diameter	Bore / Bushings	No of Teeth	Kerf	RPM
TCPR12012SC	120mm	20mm	12T	2.8 - 3.6	12000
TCPR12024SC	120mm	20mm	24T	3.1 - 4.2	12000

INDUSTRIAL



TCPR



Wood

TCT circular saw blades for crosscut and universal use for all types of wood.

Part No.	Diameter	Bore / Bushings	No of Teeth	Kerf	RPM
TCPR18524-20	ATB Positive	185mm	20/16mm	24T	2.6mm 8500
TCPR18540-20	ATB Positive	185mm	20/16mm	40T	2.6mm 8500
TCPR18560-20	ATB Positive	185mm	20/16mm	60T	2.6mm 8500
TCPR19024-30	ATB Positive	190mm	30/20/16mm	24T	2.6mm 8500
TCPR19040-30	ATB Positive	190mm	30/20/16mm	40T	2.6mm 8500
TCPR19060-30	ATB Positive	190mm	30/20/16mm	60T	2.6mm 8500
TCPR23024-30	ATB Positive	230mm	30/25.4/20/16mm	24T	3.2mm 6600
TCPR23040-30	ATB Positive	230mm	30/25.4/20/16mm	40T	2.8mm 6600
TCPR23540	ATB Positive	235mm	30/25/16mm	40T	2.8mm 6600
TCPR23560	ATB Positive	235mm	30/25.4/16mm	60T	2.8mm 6600
TCPR25040	ATB Positive	250mm	30/25.4/20/16mm	40T	3.2mm 6000
TCPR25060	ATB Positive	250mm	30/25.4/20/16mm	60T	3.2mm 6000
TCPR30040	ATB Positive	300mm	30/25.4/20mm	40T	3.2mm 5000
TCPR30060	ATB Positive	300mm	30/25.4/20mm	60T	3.2mm 5000
TCPR35030-30	ATB Positive	350mm	30/25.4mm	30T	3.2mm 4500
TCPR35096-30	ATB Positive	350mm	30/25.4mm	96T	3.5mm 4500
TCPR40030-30	ATB Positive	400mm	30/25.4mm	30T	3.8mm 3800
TCPR400100-30	ATB Positive	400mm	30/25.4mm	100T	3.6mm 3800

INDUSTRIAL

The TCPR range of blades are designed for operation in industrial shops, & have large tips. Hardened steel body runs truer & provides accurate cuts.



Blade Bushings

Part No.	Size
TCBB1612C	16 - 12mm
TCBB2016C	20 - 16mm
TCBB3016C	30 - 16mm
TCBB301C	30mm - 1"
TCBB3020C	30 - 20mm



Replacement blade bushings for circular saw blades

Quick Cut Universal TCT Saw Blade

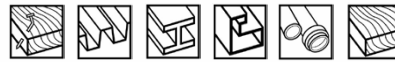

Part No.	Diameter	Bore / Bushings	No of Teeth	Kerf	RPM
TCQ16042-20	160mm	20mm	42T	2.2mm	6000
TCQ18542-20	185mm	20mm	42T	2.2mm	5000
TCQ19048-30	190mm	30/25.4/20/16mm	48T	2.2mm	5000
TCQ23054-30	230mm	30mm	54T	2.2mm	4200
TCQ25060-30	250mm	30/20/16mm	60T	2.2mm	3800

INDUSTRIAL

- Universal Saw blade for hand and table saw machines.
- Can be resharpened!
- Quicker and finer cut.
- Thinnest possible cut, with very little resistance.
- No burring, no afterwork.
- Steel • Sheet metal • Pipes • Iron • Wood • Wood with nails
- Plastics • PVC • Aluminium • Laminates



Biscuit Joiner Blades



CONTRACTOR

Designed to fit all popular makes of Biscuit Joining Machines.
Tungsten teeth can be resharpened.
Anti-kick design.

For use on BJ02 TorkCraft Biscuit Joiner

Part No. TCP10008
100 x 22.23 x 4mm - 6T
Max. RPM 16000



Angle Grinder Wood Blade

Part No.	Description	Bore	Kerf	RPM
TC911504	Saw Blade for 115mm Angle Grinder	22.23mm	2.0mm	14000

Use the Tork Craft Angle Grinder Wood blades on your angle grinder to cut and shape wood.



Push Stick

TCPS001

2 Pce Push Stick : 205mm Long/125mm High
"V" Groove on the bottom

A Push Stick is a safety device that helps you to control the movement of working piece/s when operating power tools, especially when working on tablesaws, jointers, router tables or bandsaws. The push stick keeps your hands away from the machines cutting zone, it also helps to produce smoother cuts. It is especially useful for feeding narrow stock across the table of a woodworking machine.



JIGSAW BLADE PRODUCT KNOWLEDGE



T-Shank Jigsaw blade - Fits the following saw brands; AEG (Atlas Copco), Bosch®, ELU, Flex, Hitachi®, Dewalt®, Holz-Her, Mafel, Makita®, Sparky, Milwaukee®, Metabo®
U-Shank Jigsaw blade - Fits the following saw brands; Skil®, Black & Decker®, Kress, Porter Cable®, Ryobi®

6TPI — 10TPI — 14TPI — 21TPI — 24TPI — 36TPI

Faster/Rougher ← Type of Cut → Slower/Smother

WOOD			METAL		
Teeth per Inch	Type of Cut	Materials	Teeth per Inch	Type of Cut	Materials
6 - 8	Rough	Hard & Soft Wood, Particleboard	14 - 18	Smooth	Thick Material
10 - 14	Fine	Wood & Plastics	24	Smooth	Thin Material
16 - 20	Very Fine	Plywood, Laminated Particleboard	36	Very Smooth	Very Thin Material

How to use a Jig Saw.

The jig saw works along the same principles as a sewing machine.

The cutting speed of the upwards/downwards movements can be adjusted in degrees, or can be regulated electronically.

The cutting speed ranges from 200 to 3000 cut/minute.*

When using harder materials, for example metals, lower cutting speeds are used. With softer materials like woods, higher cutting speeds are more appropriate.

The clamped sawing blade is designed to cut during the upward movement. This is aided by the so-called pendulum cut.

The pendulum cut ensures that the blade is pressed against the material with extra force during the upward movement. In this way, it is possible to saw faster, while using the same amount of energy.

* Determined by machine and manufacturer.

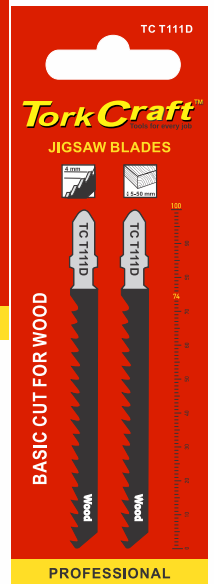
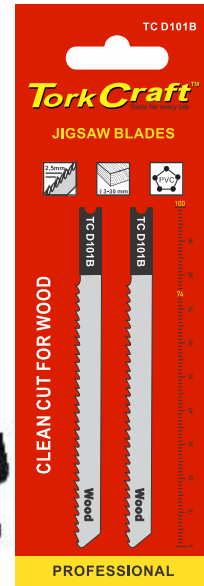

T-Shank Jigsaw Blades

Part No. TC T101B-2 / TC T101B-5

Ideal for fine cuts in hardwood, softwood, plywood, laminated particleboard and plastics.

A 2,5 mm / 10 t.p.i. **B** 75 mm **C** 100 mm

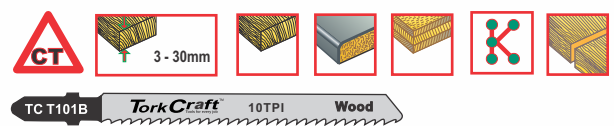

Part No. TC T101BR-2 / TC T101BR-5

Reverse tooth. For splinter-free cutting of hardwood, softwood, plywood, laminated particleboard and plastics.

A 2,5 mm / 10 t.p.i. **B** 75 mm **C** 100 mm

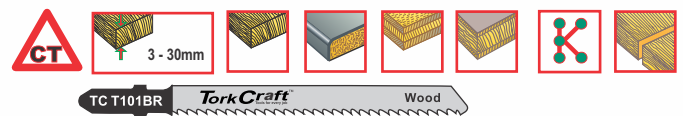

Part No. TC T101AO-2 / TC T101AO-5

For precise, splinter-free cuts on both sides of the material. For curved cuts in hardwoods, softwoods, plywood, wooden fibreboard and plastic.

A 1,3 mm / 20 t.p.i. **B** 50 mm **C** 75 mm



Part No. TC T101D-2 / TC T101D-5

Ideal for fast, clean cuts in hardwood, softwood, particleboard and plastics.

A 4 mm / 6 t.p.i. **B** 75 mm **C** 100 mm

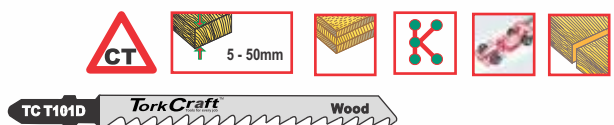

Part No. TC T111C-2

For fast, coarse cuts in hardwood, softwood and plastics.

A 3 mm / 8 t.p.i. **B** 75 mm **C** 100 mm

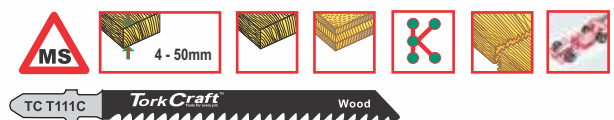

T-Shank Jigsaw Blades

Part No. TC T111D-2

Ideal for fast, rough cuts in hardwood, softwood and plastic.

A 4 mm / 6 t.p.i. **B** 75 mm **C** 100 mm

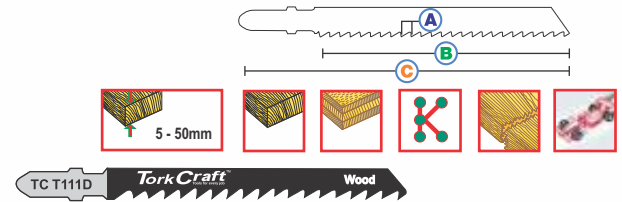

Part No. TC T144D-2 / TC T144D-5

Ideal for straight and parallel cuts. Very fast, clean cuts in hardwood, softwood and particleboard.

A 4 mm / 6 t.p.i. **B** 75 mm **C** 100 mm

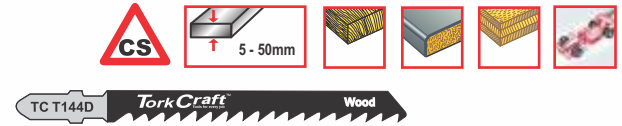

Part No. TC T244D-2

For very fast, clean curve cutting in hardwood, softwood and particleboard.

A 4 mm / 6 t.p.i. **B** 75 mm **C** 100 mm

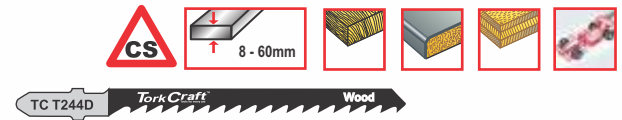

Part No. TC T118A-2 / TC T118A-5

Ideal for thin material. Straight cuts in metal, non-ferrous metal, sheet metal and aluminium.

A 1.2 mm / 21 t.p.i. **B** 50 mm **C** 75 mm

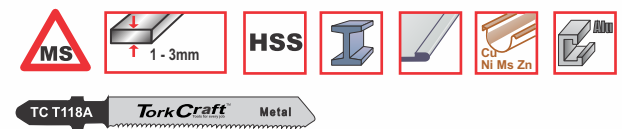

Part No. TC T118AF-2

For thin materials. Straight cuts (flexible and shatter-proof) in soft steel, aluminium, steel, stainless steel and acrylic glass.

A 1.2 mm / 21 t.p.i. **B** 50 mm **C** 75 mm

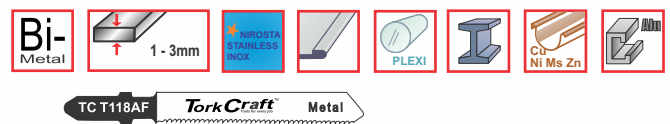

Part No. TC T118B-2

Ideal for thick material. Straight cuts in metal, non-ferrous metal and aluminium.

A 2 mm / 12 t.p.i. **B** 50 mm **C** 75 mm

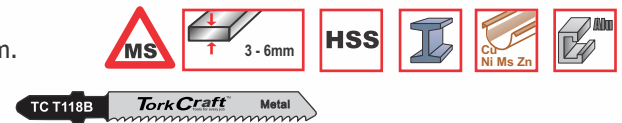

Part No. TC T118BF-2

For thick materials. Straight cuts (flexible and shatter-proof) in metals, non-ferrous metal, aluminium and acrylic glass.

A 2 mm / 12 t.p.i. **B** 50 mm **C** 75 mm

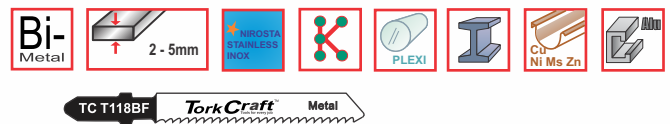

Part No. TC T118G-2

Ideal for very thin material. Straight cuts in metal, non-ferrous metal, sheet metal and aluminium.

A 0.9 mm / 28 t.p.i. **B** 50 mm **C** 75 mm



Part No. TC T101A-2

Clean cut for acrylic, non-ferrous metal, perspex and polycarbonate

A 2 mm / 12 t.p.i. **B** 75 mm **C** 100 mm

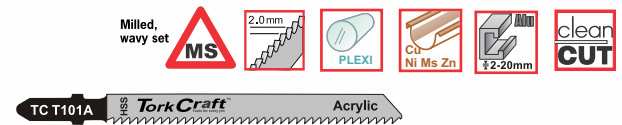

Part No. TC T101AIF-2

Clean cut wood(1.5 - 15mm) hardwood, laminates and plastics

A 1.7 mm / 14 t.p.i. **B** 75 mm **C** 100 mm

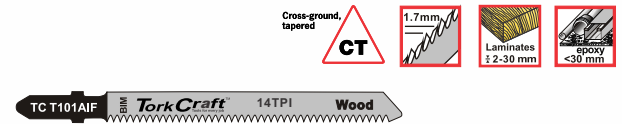

Part No. TC T101AOF-2

Clean cut for hardwood, laminate boards, plastics and epoxy

A 1.4 mm / 18 t.p.i. **B** 50 mm **C** 75 mm

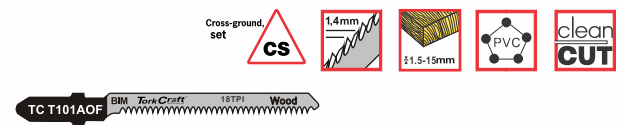

Part No. TC T101BO

Clean cut wood, laminates (3 - 65mm) & plastic. Suitable for curve cuts.

A 2,5 mm / 10 t.p.i. **B** 75 mm **C** 100 mm

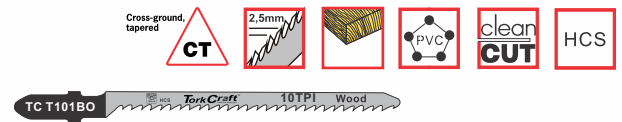

What regulates the cut speed and performance?

- » The motor power (wattage) of the machine / The effort output when sawing / The quality and accuracy of blade selection / The accurate selection of pendulum cut. When using a high pendulum cut, cracks may appear on the cutting edge.



T-Shank Jigsaw Blades

Part No. TC T150RIFF-2

Special cut for ceramics, wall tiles, glass, fibreglass, reinforced plastics and cast iron

A - mm / - t.p.i. **B** 50 mm **C** 77 mm

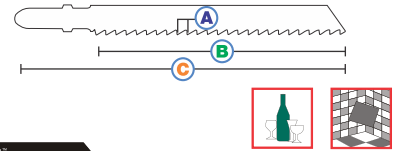

Part No. TC T123X-2

Progressor cut for metal, thick metal plate, pipes, profiles & aluminium.

A 1.2-2.6mm/10 t.p.i. **B** 75 mm **C** 100 mm

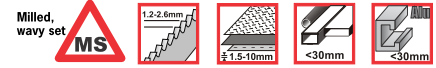

Part No. TC T102H

Clean cut wood, laminates & plastic.

A 2.3 mm / 11 t.p.i. **B** 75 mm **C** 100 mm

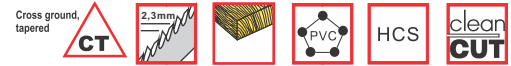

Part No. TC T234X-2

Progressor cut for soft wood, chipboard, plywood and fibreboard

A 2.3 mm / 9 t.p.i. **B** 95 mm **C** 116 mm

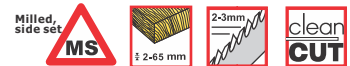

Part No. TC T301CDF-2

Clean cut in hardwood, softwood (4 - 65mm), & laminates

A 3 mm / 8 t.p.i. **B** 95 mm **C** 116 mm



Part No. TC T345XF-2

Progressor cut for wood and metal. Construction timber with nails, wood, plastics, metal plate, pipes, profiles and aluminium

A 2.4 - 5 mm / 5 t.p.i. **B** 107 mm **C** 132 mm

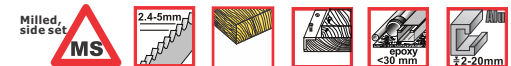

Part No. TC T344CB-2

Fast cut in thick hardwood, and softwood (5 - 100mm), all types of boards & laminates

A 4 mm / 6 t.p.i. **B** 120 mm **C** 152 mm



Part No. TC T744D-2

Speed cut for wood, thick timber construction

A 4 mm / 6 t.p.i. **B** 154 mm **C** 180 mm



Part No. TC T1044D-2

Fast cut in softwood (3 - 200mm), chipboard, wood core plywood & fibre boards

A 4 mm / 6 t.p.i. **B** 224 mm **C** 250 mm

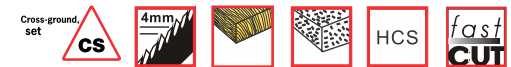

Jigsaw Blade Sets



TC T5-1
5 Pce Assorted
Jigsaw Blades



TC SET2
10 Pce Assorted
Jigsaw Blades
Metal & Wood



TC D5-1
5 Pce Assorted
Jigsaw Blades



Part No. TC T16-1
16 Pce Universal Fit
Jigsaw Blade Set

U-Shank Jigsaw Blades

Part No. TC D101B-2 / TC D101B-5

Ideal for fine cuts in hardwood, softwood, plywood, laminated particleboard and plastics.

A 2.5 mm / 10 t.p.i. **B** 75 mm **C** 100 mm

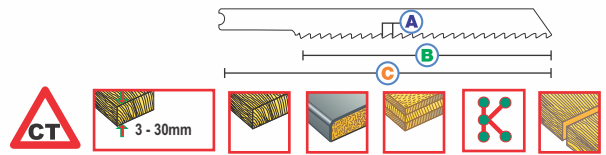

Part No. TC D101BR-2 / TC D101BR-5

Reverse tooth. For splinter-free cutting of hardwood, softwood, plywood, laminated particleboard and plastics.

A 2.5 mm / 10 t.p.i. **B** 75 mm **C** 100 mm

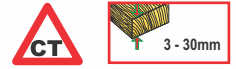

Part No. TC D101AO-2 / TC D101AO-5

For precise, splinter-free cuts on both sides of the material. For curved cuts in hardwoods, softwoods, plywood, wooden fibreboard and plastic.

A 1.4 mm / 20 t.p.i. **B** 50 mm **C** 75 mm



Part No. TC D101D-2

Ideal for fast, clean cuts in hardwood, softwood, particleboard and plastics.

A 4 mm / 6 t.p.i. **B** 75 mm **C** 100 mm

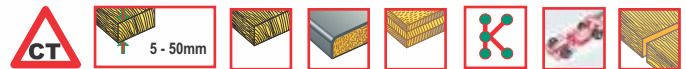

Part No. TC D118A-2 / TC D118A-5

Ideal for thin material. Straight cuts in metal, non-ferrous metal, sheet metal and aluminium.

A 1,2 mm / 21 t.p.i. **B** 50 mm **C** 75 mm



Part No. TC D118AF-2

For thin materials. Straight cuts (flexible and shatter-proof) in soft steel, aluminium, steel, stainless steel and acrylic glass.

A 1.2 mm / 21 t.p.i. **B** 50 mm **C** 75 mm



Part No. TC D118B-2

Ideal for thick material. Straight cuts in metal, non-ferrous metal and aluminium.

A 2 mm / 12 t.p.i. **B** 50 mm **C** 75 mm



Part No. TC D118BF-2

For thick materials. Straight cuts (flexible and shatter-proof) in metals, non-ferrous metal, aluminium and acrylic glass.

A 2 mm / 12 t.p.i. **B** 50 mm **C** 75 mm



Part No. TC D119BO-2

For narrow curve cutting in hardwood, softwood, plywood, particleboard, plastics and perspex.

A 2 mm / 12 t.p.i. **B** 50 mm **C** 75 mm



Planer Blades

Part No.	Description
TC CUT2902	Planer Blades Tungsten 82mm (2/pk)
TC CUT2903	Planer Blades Tungsten 60mm (2/pk)
TC CUT2904	Quick change Planer Blades plus holder
TC CUT2905	Carbide Electric Planer Blades 82 x 5.5 x 1.1mm (2/pk)
TC CUT2906	HSS Planer Blades 82 x 5.5 x 1.1mm (2/pk)
CUT29.2	Planer Blade Tungsten 82mm (2/pk)

Fits most makes and brands of electric hand planers.
Reversible blades give two sharp edges. 2 Pce/pack

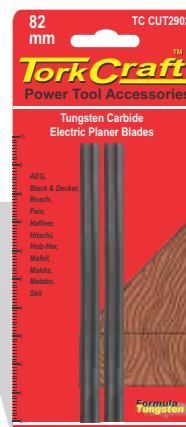

Scroll Saw Blades



Wood



Plastic



Non-ferrous Metal

Part No.	Length & TPI	Pack Size
SSB40501	20TPI with pins	6/pack
SSB41001	7TPI with pins	6/pack
SSB41101	15TPI with pins	6/pack
SSB41201	10TPI with pins	6/pack
SSB42003	9TPI with pins Reverse Tooth	6/pack
SSB42401	18.5TPI with pins	6/pack
SSB42701	25TPI with pins	6/pack
SSB427	25TPI plain	12/pack
SSB48700	25TPI Metal cutting	12/Pack

Application/Material

- For sawing wood, plastic and non-ferrous metals

Features/Benefit

- Precision sharpened to cut fine intricate shapes
- Pinned-end styles to fit most popular machines



Part No.	Length & TPI	Pack Size
SSB402DZ	125mm 25TPI Wood Plain end	6/pack
SSB405DZ	125mm 20TPI Wood Plain end	6/pack
SSB406DZ	125mm 20TPI Metal Plain end	6/pack
SSB411DZ	125mm 15TPI Wood Plain end	6/pack
SSB412DZ	125mm 10TPI Wood Plain end	6/pack
SSB46300	125mm 41TPI Spiral Cut Wood Plain end	6/pack
SSB46500	125mm 36TPI Spiral Cut Wood Plain end	6/pack
SSB47500	61TPI Jewelers Metal Piercing Plain End	6/pack
SSB47600	56TPI Jewelers Metal Piercing Plain End	6/pack
SSB47900	48TPI Jewelers Metal Piercing Plain End	6/pack
SSB48000	43TPI Jewelers Metal Piercing Plain End	6/pack
SSB47800	51TPI Jewelers Metal Piercing Plain End	6/pack

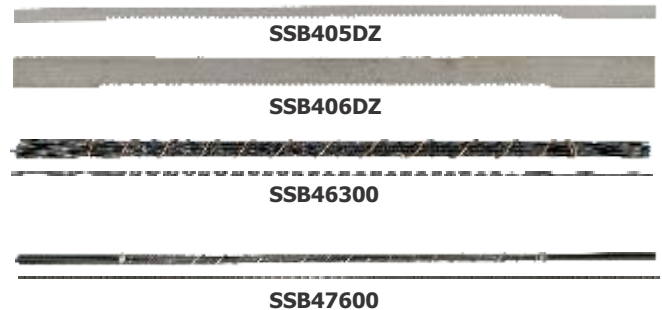

SSB63507	Scroll/Fret Saw Frame 250mm Deep Plain End	6/pack
----------	--	--------



SSB63507



Scroll Saw Sander

Part No.	Length & TPI	Pack Size
SSB1212BL	125mm x 1/4" 120G Pin End	4/pack
SSB1218BL	125mm x 1/4" 180G Pin End	4/pack
SSB1222BL	125mm x 1/4" 220G Pin End	4/pack
SSB1508BL	125mm x 1/2" 80G Pin End	4/pack
SSB1512BL	125mm x 1/2" 120G Pin End	4/pack
SSB1518BL	125mm x 1/2" 180G Pin End	4/pack
SSB1522BL	125mm x 1/2" 220G Pin End	4/pack
SSB2212BL	125mm x 1/4" 120G Plain End	4/pack
SSB2218BL	125mm x 1/4" 180G Plain End	4/pack
SSB2222BL	125mm x 1/4" 220G Plain End	4/pack
SSB2508BL	125mm x 1/2" 80G Plain End	4/pack
SSB2512BL	125mm x 1/2" 120G Plain End	4/pack
SSB2518BL	125mm x 1/2" 180G Plain End	4/pack
SSB2522BL	125mm x 1/2" 220G Plain End	4/pack



Oscillating Blades - Universal Fitting

Part no.	Description
TCOA001	Quick Change Carbide Grit Delta Rasp 80mm (3-1/8")
TCOA002	Quick Change Carbide Grit Radial Saw Blade 65mm (2-9/16")
TCOA003	Quick Change Diamond Boot Saw Blade 65mm (2-9/16")
TCOA004	Quick Change Flush Cut Metal Saw Blade 10mm (3/8") 18TPI
TCOA005	Quick Change Flush Cut Metal Saw Blade 22mm (7/8") 18TPI
TCOA006	Quick Change Flush Cut Metal Saw Blade 28mm (1-1/8") 18TPI
TCOA007	Quick Change Flush Cut Universal Saw Blade 45mm (1-3/4") 18TPI
TCOA008	Quick Change Flush Cut Universal Saw Blade 65mm (12-1/2") 18TPI
TCOA009	Quick Change Flush Cut Wood Saw Blade 28mm (1-1/8") 18TPI CRV
TCOA010	Quick Change Flush Cut Wood Saw Blade 34mm (1-5/16") 14TPI CRV
TCOA011	Quick Change Flush Cut Wood Saw Blade 68mm (2-11/16") 14TPI CRV
TCOA012	Quick Change Radial Saw Blade 87mm (3-7/16") CRV Wood Saw
TCOA013	Quick Change Radial Saw Blade 87mm (3-7/16") M42 Metal Saw
TCOA014	Quick Change Rigid Scraper 52x26mm (2-1/16" x 1")
TCOA015	Quick Change Sharp Scraper 28x50mm (1-1/8" x 2")
TCOA105	Quick Change Flexible Scraper 52 x 45mm (2-1/16" x 1 - 3/4")
TCOA016	Quick Change Grout And Mortar Remover 65mm (2-9/16")
TCOA017	Quick Change Segment Saw Blade 80mm (3-1/8") Ferrous & Non-ferrous



Part No. TCOT001
Oscillating Multi-Function Tool
Cordless 12V Li-ion 1.3AH
Includes charger & battery

TCBP001

Fast Charger for 12V Li-ion 1.3AH & 1.5AH
Battery Pack

TCBP001-1

12V Li-ion 1.3AH Spare Battery for
TORKCRAFT Cordless Tools

TCBP001-2

12V Li-ion 1.5AH Spare Battery for
TORKCRAFT Cordless Tools



TCOA001



TCOA002



TCOA003



TCOA004



TCOA005



TCOA006

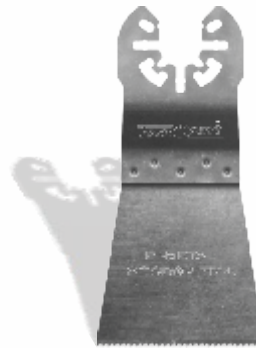

TCOA007



TCOA008



TCOA009

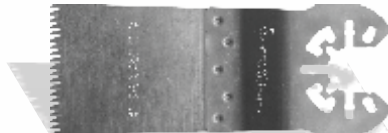

TCOA010

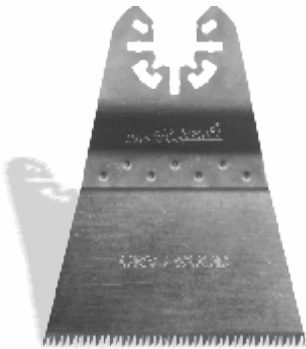

TCOA011



TCOA012



TCOA013

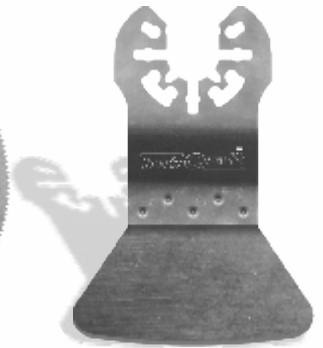

TCOA014



TCOA015



TCOA105



TCOA016



TCOA017

Oscillating Blade Sets



Part No. TCOA101
2 Pce Quick Change Oscillating Carbide Grit Accessory Kit



Part No. TCOA102
4 Pce Quick Change Oscillating Floor Working Accessory Kit



Part No. TCOA103
4 Pce Quick Change Oscillating General Purpose Accessory Kit



Part No. TCOA104
4 Pce Quick Change Oscillating Tile Working Accessory Kit

Part No. TCOA100
10 Pce Quick Change Oscillating Multi Purpose Accessory Kit



Oscillating Sandpaper

Part no.	Description
TCOA018-80	10 Pce - 93mm Delta Shape 80 Grit
TCOA018-120	10 Pce - 93mm Delta Shape 120 Grit
TCOA018-180	10 Pce - 93mm Delta Shape 180 Grit
TCOA018-240	10 Pce - 93mm Delta Shape 240 Grit
TCOA019-80	10 Pce - 80mm Delta Shape 80 Grit
TCOA019-120	10 Pce - 80mm Delta Shape 120 Grit
TCOA019-180	10 Pce - 80mm Delta Shape 180 Grit
TCOA019-240	10 Pce - 80mm Delta Shape 240 Grit
TCOA020-80	10 Pce - 35 x 50mm Fingertip 80 Grit
TCOA020-120	10 Pce - 35 x 50mm Fingertip 120 Grit
TCOA020-180	10 Pce - 35 x 50mm Fingertip 180 Grit
TCOA020-240	10 Pce - 35 x 50mm Fingertip 240 Grit
TCOA021-80	10 Pce - 115mm Round 80 Grit
TCOA021-120	10 Pce - 115mm Round 120 Grit
TCOA021-180	10 Pce - 115mm Round 180 Grit
TCOA021-240	10 Pce - 115mm Round 240 Grit



TCOA018



TCOA019



TCOA020



TCOA021



TCOA201

Backing & Felt Pads

Part no.	Description
TCOA201	Quick Change 115mm Micro Sanding Velcro Backing Pad
TCOA202	Quick Change 35mm Fingertip Felt Polishing Pad
TCOA203	Quick Change 80mm Delta Micro Velcro Backing Pad
TCOA204	Quick Change 80mm Delta Felt Polishing Pad
TCOA205	Quick Change 93mm Delta Micro Velcro Backing Pad
TCOA206	Quick Change 35mm Fingertip Felt Polishing Pad
TCOA207	Quick Change 35mm Micro Velcro Backing Pad
TCOA208	Quick Change 35mm Fingertip Micro Velcro Backing Pad



TCOA202



TCOA201



TCOA205

Hose Clamps

Part No.	Description
HC6-17	6 - 17mm ea (10/Box GM4)
HC6-22	6 - 22mm ea (10/Box GM6)
HC8-27	8 - 27mm ea (10/Box GM7)
HC11-20	11 - 20mm ea (10/Box K6)
HC11-23	11 - 23mm ea (10/Box K8)
HC14-27	14 - 27mm ea (10/Box KM10)
HC17-32	17 - 32mm ea (10/Box K12)
HC19-38	19 - 38mm ea (10/Box K16)
HC21-44	21 - 44mm ea (10/Box K20)
HC27-51	27 - 51mm ea (10/Box K24)
HC33-57	33 - 57mm ea (10/Box K28)
HC40-64	40 - 64mm ea (10/Box K32)
HC46-70	46 - 70mm ea (10/Box K36)
HC52-76	52 - 76mm ea (10/Box K40)
HC59-83	59 - 83mm ea (10/Box K44)
HC65-89	65 - 89mm ea (10/Box K48)
HC71-95	71 - 95mm ea (10/Box K52)
HC78-102	78 - 102mm ea (10/Box K56)
HC6-17P	6 - 17mm ea (2Pce Packaged GM4)
HC6-22P	6 - 22mm ea (1Pce Packaged)

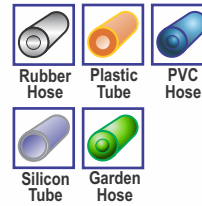

Band, housing and screw made from AISI 101 Stainless Steel

Heavy Duty Hose Clamps

Part No.	Description
HCHD29-31	29 - 31mm (10/bag)
HCHD32-35	32 - 35mm (10/bag)
HCHD36-39	36 - 39mm (10/bag)
HCHD23-26	23 - 26mm (10/bag)
HCHD26-28	26 - 28mm (10/bag)
HCHD40-43	40 - 43mm (10/bag)
HCHD44-47	44 - 47mm (10/bag)
HCHD48-51	48 - 51mm (10/bag)
HCHD56-59	56 - 59mm (10/bag)
HCHD60-63	60 - 63mm (10/bag)
HCHD64-67	64 - 67mm (10/bag)
HCHD68-73	68 - 73mm (10/bag)
HCHD74-79	74 - 79mm (10/bag)
HCHD80-85	80 - 85mm (10/bag)
HCHD86-91	86 - 91mm (10/bag)
HCHD92-97	92 - 97mm (10/bag)
HCHD98-103	98 - 103mm (10/bag)

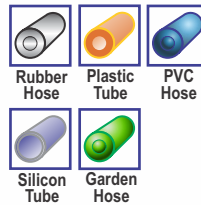

Band and housing made from AISI 101 Stainless Steel and screw 5/16" made from zinc plated carbon steel

Stainless Steel Hose Clamps

Part No.	Description	Part No.	Description
HCSS11-20	11 - 20mm Bulk	HCSS33-57	33 - 57mm Bulk
HCSS11-23	11 - 23mm Bulk	HCSS40-64	40 - 64mm Bulk
HCSS14-27	14 - 27mm Bulk	HCSS46-70	46 - 70mm Bulk
HCSS17-32	17 - 32mm Bulk	HCSS65-89	65 - 89mm Bulk
HCSS19-38	19 - 38mm Bulk	HCSS71-95	71 - 95mm Bulk
HCSS21-44	21 - 44mm Bulk	HCSS78-102	78 - 102mm Bulk
HCSS27-51	27 - 51mm Bulk		

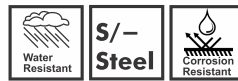

Double Ear Clamps

Part No.	Description
EC9-12	Carbon Steel 9 - 12mm (10pce / pack)
EC11-13	Carbon Steel 11 - 13mm (10pce / pack)
EC13-15	Carbon Steel 13 - 15mm (10pce / pack)
EC15-18	Carbon Steel 15 - 18mm (10pce / pack)
EC17-20	Carbon Steel 17 - 20mm (10pce / pack)



Use crimp plier to fasten



TCT ROUTER BITS PRODUCT KNOWLEDGE

- ✦ Router bits are for use with router machines only.
- ✦ Always wear ear and eye protection.
- ✦ Follow all safety and use instructions included with your router.
- ✦ Never use bits that are dull and damaged.
- ✦ Do not force the bit or overload the router.
- ✦ Be sure that at least ¾ of the shaft length is inserted into the router collet.
- ✦ Do not "bottom-out" the bit in the collet. The shank should be 1/8" from the bottom of the collet.
- ✦ Use a router table and fence whenever possible. In general, any large diameter bit should be used in a router table.
- ✦ Route in two or more passes when large amounts of stock must be removed.
- ✦ Use reduced speeds for large diameter bits.
- ✦ Failure to follow all safety instructions and warnings can result in serious bodily injury.

SUGGESTED SPEEDS	
BIT DIAMETER	MAX RPM
1" _____	24,000 RPM
1.25" _____	18,000 RPM
2.25" to 2.5" _____	16,000 RPM
3" to 3.5" _____	12,000 RPM

INCH / METRIC CONVERSION CHART

INCH	MM	INCH	MM	INCH	MM
3/32	2.40	9/16	14.30	1 1/2	38.10
1/8	3.20	5/8	15.90	1 37/64	40.00
5/32	4.00	11/16	17.50	1 5/8	41.30
3/16	4.80	3/4	19.00	1 3/4	44.50
7/32	5.60	7/8	22.20	1 7/8	47.60
1/4	6.35	15/16	23.80	2	50.80
5/16	7.90	1	25.40	2 1/8	54.00
3/8	9.50	1 1/8	28.60	2 1/4	57.20
7/16	11.10	1 3/16	30.20	2 1/2	63.50
1/2	12.70	1 1/4	31.80	2 3/4	69.90
		1 3/8	34.90	3	76.20

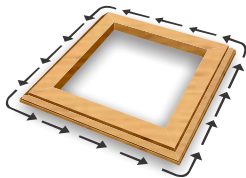

Always feed **anti-clockwise** when profiling on the **outside** of a frame or component, using a portable routing machine.



Always feed **clockwise** when profiling on the **inside** of a frame or component, using a portable routing machine.

Router Table

RT001

Router Table w/Fence & Featherboard
(for 16cm or smaller Base Routers)



Router Bits



Wood

Tork Craft Tungsten Carbide Router Bits are specially engineered to provide smooth accurate cutting for craftsmen, carpenters and hobbyists

STRAIGHT BIT	PART NO.	A	B	C	D
SINGLE FLUTE	CKP101	1/8"	1/2"	1/4"	32
SINGLE FLUTE	CKP102	3/16"	1/2"	1/4"	32
TWO FLUTE	CKP201	1/4"	3/4"	1/4"	32
TWO FLUTE	CKP202	5/16"	3/4"	1/4"	32
TWO FLUTE	CKP203	3/8"	1"	1/4"	32
TWO FLUTE	CKP204	7/16"	1"	1/4"	32
TWO FLUTE	CKP205	1/2"	1"	1/4"	32
TWO FLUTE	CKP206	9/16"	1"	1/4"	32
TWO FLUTE	CKP207	5/8"	3/4"	1/4"	32
TWO FLUTE	CKP208	3/4"	3/4"	1/4"	32
TWO FLUTE	CKP209	7/8"	3/4"	1/4"	32
TWO FLUTE	CKP210	1"	3/4"	1/2"	32
SINGLE FLUTE METRIC	CKP3MM	3MM	13	1/4"	32
SINGLE FLUTE METRIC	CKP4MM	4MM	13	1/4"	32
ONE FLUTE METRIC	CKP5MM	5MM	13	1/4"	32
TWO FLUTE METRIC	CKP6MM	6MM	20	1/4"	32
TWO FLUTE METRIC	CKP8MM	8MM	24	1/4"	32
TWO FLUTE METRIC	CKP10MM	10MM	25	1/4"	32
TWO FLUTE METRIC	CKP12MM	12MM	25	1/4"	32
TWO FLUTE METRIC	CKP16MM	16MM	20	1/4"	32
TWO FLUTE METRIC	CKP17MM	17MM	20	1/4"	32
TWO FLUTE METRIC	CKP19MM	19MM	20	1/4"	32



TRIM BIT BOTTOM BEARING

PART NO.	A	B	C	D	BEARING
CKP302	3/8"	1"	1/4"	32	KP100 3-8
CKP303	1/2"	1 1/2"	1/4"	32	KP100 1-2
CKP304	1/2"	1"	1/4"	32	KP100 1-2
CKP305	16	20	1/4"	32	Kp100 5-8

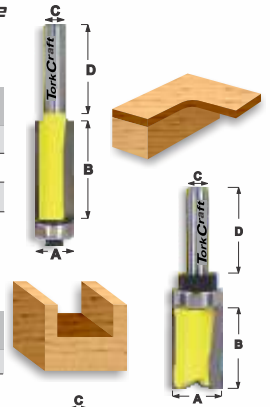

PATTERN FLUSH TRIM BIT WITH SHANK MOUNTED TOP BEARING

PART NO.	A	B	C	D	BEARING
CKP152007	1/2"	1"	1/4"	32	KP580061

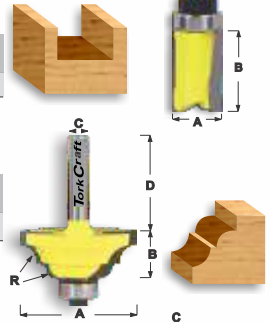

CLASSIC BIT

PART NO.	A	B	C	D	BEARING
CKP3401	1 1/4"	1 1/2"	1/4"	32	KP100 1-2
CKP3403	1 1/2"	5/8"	1/4"	32	KP100 1-2

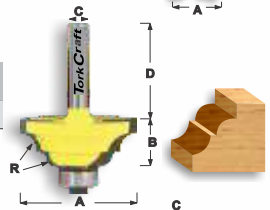

SLOT CUTTER TWO FLUTE

PART NO.	A	B	C	D	BEARING
CKP1101	1 1/4"	1 1/8"	1/4"	32	KP100 1-2
CKP1102	1 1/4"	3/16"	1/4"	32	KP100 1-2
CKP1103	1 1/4"	1/4"	1/4"	32	KP100 1-2
CKP1104	1 1/4"	5/16"	1/4"	32	KP100 1-2

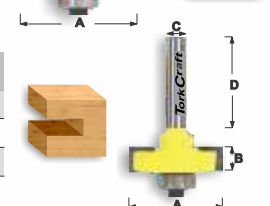

BEADING BIT

PART NO.	A	B	C	D	BEARING	RADIUS
CKP2801	7/8"	3/8"	1/4"	32	KP100 3-8	3/16"
CKP2802	1"	7/16"	1/4"	32	KP100 3-8	1/4"
CKP2803	1 1/8"	1/2"	1/4"	32	KP100 3-8	5/16"
CKP2804	1 1/4"	5/8"	1/4"	32	KP100 3-8	3/8"
CKP2805	1 1/2"	3/4"	1/4"	32	KP100 3-8	1/2"



BISCUIT SLOT CUTTER - FOUR FLUTE

PART NO.	A	B	C	D
CKP7004	2"	4	1/4"	32

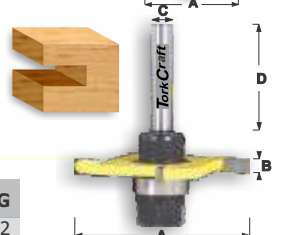

SLOT CUTTER - T-TYPE

PART NO.	A	B	C	D	BEARING
CKP903	1-1/4"	1/2"	1/2"	32	KP100 1-2



ROMAN OGEE BIT

PART NO.	A	B	C	D	BEARING	RADIUS
CKP1601	1 1/16"	1/2"	1/4"	32	KP100 3-8	5/32"
CKP1602	1 3/8"	5/8"	1/4"	32	KP100 3-8	1/4"
CKP1603	1 1/16"	3/8"	1/2"	38	KP100 3-8	5/32"

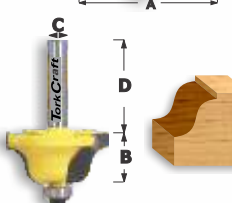

45 DEGREE CHAMFER BIT

PART NO.	A	B	C	D	BEARING
CKP901	1"	3/8"	1/4"	32	KP100 1-2
CKP902	1-3/16"	1/2"	1/4"	32	KP100 1-2

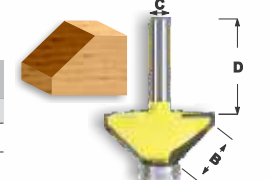

COVE BIT

PART NO.	A	B	C	D	BEARING	RADIUS
CKP1001	7/8"	3/8"	1/4"	32	KP100 3-8	1/4"
CKP1002	1-1/8"	1/2"	1/4"	32	KP100 3-8	1/4"
CKP1003	1-3/8"	5/8"	1/4"	32	KP100 3-8	1/4"
CKP1004	1-3/8"	5/16"	1/2"	32	KP100 3-8	1/2"
CKP1005	1-3/8"	1/2"	1/2"	32	KP100 3-8	1/2"

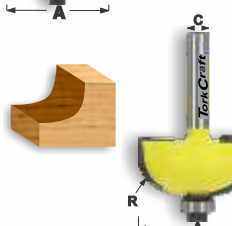

RABBETING BIT

PART NO.	A	B	C	D	BEARING	DEPTH
CKP3501	1-1/4"	3/8"	1/4"	32	KP100 1-2	3/8"
CKP3503	1-1/2"	1/2"	1/4"	32	KP100 1-2	1/2"

ALTERNATIVE BEARINGS WITH LARGER OUTSIDE DIAMETER TO REDUCE DEPTH OF CUT

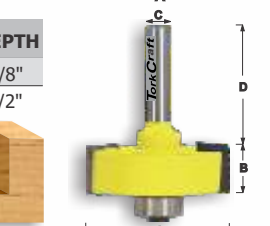

CORNER ROUND BIT

PART NO.	A	B	C	D	BEARING	RADIUS
CKP1201	7/8"	3/8"	1/4"	32	KP100 1-2	3/16"
CKP1202	1"	7/16"	1/4"	32	KP100 1-2	1/4"
CKP1203	1-1/8"	1/2"	1/4"	32	KP100 1-2	5/16"
CKP1204	1-1/4"	5/8"	1/4"	32	KP100 1-2	3/8"
CKP1205	1-1/2"	3/4"	1/4"	32	KP100 1-2	1/2"
CKP1206	7/8"	1/2"	1/2"	38	KP100 1-2	3/16"
CKP1207	1"	1/2"	1/2"	38	KP100 1-2	1/4"
CKP1208	1-1/8"	1/2"	1/2"	38	KP100 1-2	5/16"
CKP1209	1-1/4"	5/8"	1/2"	38	KP100 1-2	3/8"

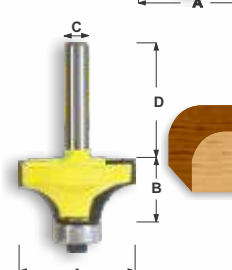

CORE BOX BIT

PART NO.	A	B	C	D	RADIUS
CKP801	1/4"	1/4"	1/4"	32	1/8"
CKP802	3/8"	3/8"	1/4"	32	3/16"
CKP803	1/2"	3/8"	1/4"	32	1/4"
CKP804	5/8"	5/8"	1/4"	32	5/16"
CKP1210	3/8"	3/4"	1/2"	38	1/2"
CKP1211	1/2"	3/4"	1/2"	38	5/8"

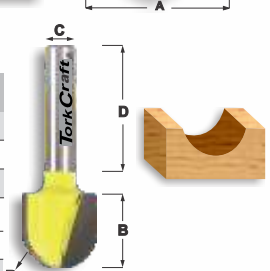

"V" GROOVE BIT 90 DEGREE

PART NO.	A	B	C	D
CKP701	3/8"	1 1/2"	1/4"	32
CKP702	1/2"	1 1/2"	1/4"	32
CKP703	5/8"	5/8"	1/4"	32



DOVETAIL BIT

PART NO.	A	B	C	D
CKP402	1/2"	1/2"	1/4"	32

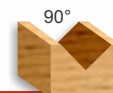

Router Bit Sets



Part No. DY012B AG
12 Pce Set in aluminium case
1/4" Shank
(w/transparent top)
Part No. TC20505
12 Pce Set in aluminium case
1/4" Shank



Part No. TC20507
24 Pce Set in aluminium case 1/4" Shank
Part No. DY024A AL
24 Pce Set in aluminium case 1/4" Shank
Part No. DY024A AG
24 Pce Set in aluminium case 1/4" Shank
(with transparent top)
Part No. DY024A-2 AL
24 Pce Set in aluminium case 1/2" Shank



Part No. DY030 WB
30 Pce Set in wooden case "B"
1/4" Shank



Part No. DY035B AL
35 Pce Set in aluminium case "B" 1/4" Shank
Part No. DY035B AG
35 Pce Set in aluminium case 1/4" Shank
(with transparent top)



Part No. TC20509
35 Pce Set in aluminium case
1/4" Shank

All CKP TorkCraft router bits can cut:

- » Hardwood
- » Softwood
- » Medium Density Fibreboard (MDF)
- » Chip Board



Router Bit Sets



Part No. TC600601
6 Pce Set in wooden box
1/4" Shank



Part No. DY006A PL
6 Pce Set in plastic case
1/4" Shank



Part No. DY012B PL
12 Pce Set in plastic case
1/4" Shank

Reliable cuts every time

Visit our website to see our wide selection of router bits in different sizes to choose your perfect shape



DIAMOND BLADE PRODUCT KNOWLEDGE

Diamond Blade Features and Information

What is a Diamond Blade - A diamond blade is composed of a circular steel core and the diamond impregnated segment. The segments are separated by slots in the core. These slots assist in cooling the blade during operation by allowing water (wet cutting) or air (dry cutting) to flow between the segments. The segments or rims are a mixture of diamond powders and metal powders. The diamonds are industrial diamonds of different sizes and qualities depending on the material to be cut as well as the blade type.

How does a Diamond Blade work - The individual diamond crystals exposed on the leading edge and the sides of the segment or rim carry out the cutting. The operator pushes the rotating blade into the material and the surface diamonds thus exposed mill a groove in the material, reducing it to fine powder. When the blade mills the material, the latter exerts wear on the blade. During cutting the exposed diamonds may crack or break. The material simultaneously starts to abrade the metal matrix, which gradually releases more diamonds. The more abrasive the material, the more rapid the tendency to wear down the matrix.

Blades for cutting hard, dense less abrasive materials (such as tile, hard bricks, stone or cured concrete), require a softer metal matrix. This will wear down faster, replacing the worn diamonds fairly quickly so that the blade continues to cut. Blades for cutting soft, abrasive materials (such as green concrete and asphalt), must have a hard, abrasion-resistant metal matrix in order to retain the diamonds for a long time.

Different methods of making Diamond Blades;

Laser welding - Laser micro-fusion enables the segment to be welded to the core. This bond is the most powerful, and enables the tool to be used for dry cutting and drilling without segment loss.

Brazing - Silver brazing solder melts at high temperatures between the segment and the core and binds the two elements together. Used for wet cutting, drilling and grinding.

Sintering - Divides into two;

- a) Cold Pressed - First pressed with press machine under normal conditions, then laid in sinter machine under high pressure and temperatures making the compressed metal powder melt to a solid bond.
- b) Hot Pressed - Pressed with hot press machine under high temperature and pressure, making the compressed metal powder melt to a solid bond.

Blade Types;

- a) **Continuous smooth rim** - provides the smoothest cut in ceramic tiles and ornamental stone.
- b) **Turbo / Segmented Turbo** - may produce slight chipping but generally have a longer life and lower cost per cut than continuous rim blades.
- c) **Segmented** - provide the longest life and lowest cost per cut but are only suitable for work where chipping is not a problem.

DIAMOND BLADE APPLICATION CHART

	Segmented (wet/dry)	Turbo (wet/dry)	Continuous Rim (Wet-cut)
Screed	Not so Good	No, No	No, No
Reinforced Concrete	Great	Good	No, No
Clay Pipes	Great	Great	No, No
Concrete Pipes	Great	Good	No, No
Concrete	Great	Good	No, No
Prestressed Concrete	Great	Good	No, No
Stock Bricks	Good		No, No
Clay Pavers	Great	Great	No, No
Semi Face Bricks	Great	Good	No, No
Face Bricks	Great	Great	No, No
High Alimina Refractory Bricks	Not so Good	Good	No, No
Refractory Bricks	Great	Good	No, No
Clay Roof Tiles	Great	Good	No, No
Cement Roof Tiles	Great	Not so Good	No, No
Concrete Paving Slabs	Great	Not so Good	No, No
Teracotta Floor Tiles	Great	Great	No, No
Slate	Great	Great	No, No
Terrazzo	Great	Great	No, No
Tiles & Glazed Tiles	No, No	Great	Great
Granite	Good	Great	Good
Porcelain	No, No	No, No	Great
Marble	Good	Great	Great





Royal Blue Laser

Part No.	Diameter	Bore / Bushings	RPM
Segmented			
TCDB1420115	115mm	22.23mm	13200
TCDB1420230	230mm	22.23mm	6600
Turbo Segmented			
TCDB1430115	115mm	22.23mm	13200
TCDB430125	125mm	22.23mm	12000
TCDB430230	230mm	22.23mm	6600

Hot Pressed Emerald Green

Part No.	Diameter	Bore / Bushings	RPM
Segmented			
TCDB1220115	115mm	22.23mm	13200
TCDB1220230	230mm	22.23mm	6600
TCDB10300	300mm	25.4mm	5000
Turbo			
TCDB1230115	115mm	22.23mm	13200
Continuous			
TCDB1210115	115mm	22.23mm	13200

Sintered Silver

Part No.	Diameter	Bore/Bushings	RPM
Segmented			
DB2	115mm	22.23mm	13000
DB2-2 w/12mm deep segments	115mm	22.23mm	13200
DB3	230mm	Concrete	22.23mm 6600
DB3-2 w/12mm deep segments	230mm	Granite	22.23mm 6600
DB3-3 w/12mm deep segments	230mm	Concrete	22.23mm 6600
Turbo			
DB5	115mm	22.23mm	13200
DB4	230mm	22.23mm	6600
DB7 w/12mm deep segments	110mm x 1.2 x 8mm	22.23mm	13200
Continuous			
DB1	115mm	22.23mm	13000
DB6	230mm	22.23mm	6600

Sintered Gold

Part No.	Diameter	Segment Height	Bore/Bushings	RPM
Segmented				
TCDB20115	115mm	7mm	22.23mm	13200
TCDB20115-3	115mm	10mm	22.23mm	12000
TCDB20125	125mm	7mm	22.23mm	8400
TCDB20180	180mm	7mm	22.23mm	6600
TCDB20230	230mm	7mm	22.23mm	6600
TCDB20230-4	230mm	10mm	22.23mm	6600
Turbo Wave				
TCDB40115	115mm	8mm	22.23mm	13200
TCDB40180	180mm	8mm	22.23mm	8400
TCDB40180-2	180mm	8mm	25.4mm	8400
TCDB40200	200mm	8mm	25.4mm	7600
TCDB40230	230mm	8mm	22.23mm	6600
Turbo Segmented				
TCDB50230	230mm	10mm	22.23mm	6600
Continuous				
TCDB10115	115mm	5mm	22.23mm	13200
TCDB11018-2	180mm	5mm	22.23mm	8400
TCDB1110180	180mm	5mm	25.4mm	8400
TCDB1110200	200mm	5mm	22.23mm	7600
TCDB1110230	230mm	5mm	22.23mm	6600
TCDB1110230-2	230mm	5mm	25.4mm	6600
TCDB1110230-3	230mm	6mm	22.23mm	6600



See Application Chart on Pg 21

INDUSTRIAL
Laser Welding
 Laser micro-fusion enables the segment to be welded to the core. This bond is the most powerful, & enables the tool to be used for dry cutting and drilling without segment loss.
Application : Concrete, brick, paving, roof tiles & construction material.



See Application Chart on Pg 21

INDUSTRIAL
Hot Pressed
 Pressed with a hot press under high temperatures and pressure, making the compressed metal powder melt to a solid bond.
Application : Concrete, brick, paving, roof tiles, tiles (continuous rim) & construction material.

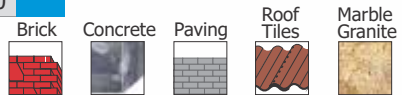

See Application Chart on Pg 21

CONTRACTOR
Sintering - Cold Pressed
 First pressed with a press under normal conditions, then laid in a sinter machine under high pressure and temperatures making the compressed metal powder melt to a solid bond.
Application : Concrete, brick, granite, paving, roof tiles, continuous rim tiles & construction material.



See Application Chart on Pg 21

CONTRACTOR
Sintering - Cold Pressed
 First pressed with a press under normal conditions, then laid in sinter machine under high pressure and temperatures making the compressed metal powder melt to a solid bond.
Application : Concrete, brick, paving, roof tiles, tiles (continuous rim) & construction material.



Dished Cymbal - Turbo



Marble
Granite



Natural
Stone slabs

Application: Curves in granite and marble tops, cutouts for drop-in basins

Part No.	Diameter	Bore / Bushings	INDUSTRIAL
TC701125	125mm	22.23mm	
TC701180	180mm	22.23mm	

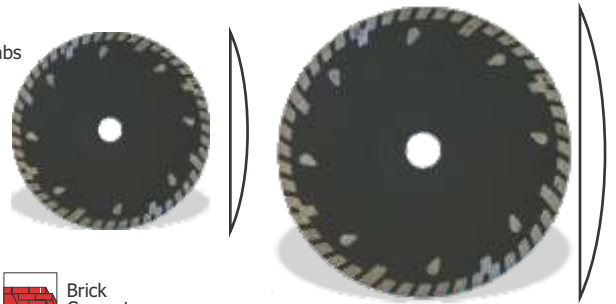

Cup Grinding Wheels



Masonry
Slate



Marble
Granite



Brick
Concrete

Application: Surface clean up, granite, masonry, concrete and stone

Part No.	Diameter	Bore / Bushings	RPM	
Double Row				
TCCW20115-1	115mm	22.23mm	10400	Sintered
TCCW20115-2	115mm	22.23mm	10400	Welded
TCCW20115-3	115mm	M14	10400	Sintered
TCCW20115-4	115mm	M14	10400	Welded
Turbo				
TCCW40100-1	100mm	22.23mm	10400	Cold Pressed
TCCW40115-1	115mm	22.23mm	10400	Sintered
TCCW40115-2	115mm	22.23mm	10400	Welded
TCCW40115-3	115mm	M14	10400	Sintered
TCCW40115-4	115mm	M14	10400	Welded
TCCW40180-1	180mm	22.23mm	10400	Cold Pressed
TCCW40180-2	180mm	22.23mm	10400	Laser Welded
TCCW40180-3	180mm	M14	10400	Cold Pressed
TCCW40180-4	180mm	M14	10400	Laser Welded



Cutting Blades - Segmented



Brick
Concrete

See Application Chart on Pg 21

Part No.	Diameter	Bore/ Bushings	Locating Hole	RPM
General Purpose - Laser Welded				
TCDB20300-2	300mm	25.4mm	Bottom	5000
Asphalt - Hot Pressed				
TCDB20300-1	300mm	25.4mm	Bottom	5000
TCDB20300-10	300mm	25.4mm	Bottom	5000
TCDB20350-5	350mm	25.4mm	Bottom	4300
TCDB1210350A	350mm	25.4mm	Side	4300
Asphalt - Laser Welded				
TCDB20300-14	300mm	25.4mm	Bottom	5000
TCDB20350-6	350mm	25.4mm	Side	4300
TCDB20350-20	300mm	25.4mm	Bottom	4300
Concrete - Hot Pressed				
TCDB20300-11	300mm	25.4mm		5000
TCDB20350-3	350mm	25.4mm	Side	4300
Concrete - Laser Welded				
TCDB20300-15	300mm	25.4mm	Bottom	5000
TCDB20350-21	350mm	25.4mm	Bottom	4300
TCDB20350-4	350mm	25.4mm		
Old & Green - Hot Pressed				
TCDB20350-1	350mm	25.4mm	Bottom	4300
Old Concrete - Laser Welded				
TCDB20300-16	300mm	25.4mm	Bottom	5000
TCDB20350-22	350mm	25.4mm	Side	4300
TCDB20350-2	350mm	25.4mm	Bottom	4300
Old Concrete - Hot Pressed				
TCDB20300-12	300mm	25.4mm	Bottom	5000

INDUSTRIAL



TCDB20350-5



TCDB20300-14

Contractor Bulk Packs
TCDB20115-5P
TCDB20230-5P



Metal Cutting - Segmented



Part No.	Diameter	Bore / Bushings
TCDB70115	115mm	22.23mm
TCDB70115-1 <i>Vacuum Brazed</i>	115mm	22.23mm
TCDB70230	230mm	22.23mm
TCDB70230-1 <i>Vacuum Brazed</i>	230mm	22.23mm
TCDB70300	300mm	25.4mm
TCDB70350	350mm	25.4mm

INDUSTRIAL

Tork Craft brings you the latest technology in diamond cutting: the all new Metal Cutting Diamond Blades will outlast conventional blades many times over!



TCDB70115



TCDB70350

Multi-Purpose Diamond Blade

Part No.	Description
TCDB50115	115mm Multi-purpose Diamond Blade - Segmented
TCDB50230-2	230mm Multi-purpose Diamond Blade - Segmented

A diamond blade for hard and soft materials!

- A unique and revolutionary concept!
- The combination of two different segments in a single blade means it can be used to cut either hard or soft materials with perfect results for both!

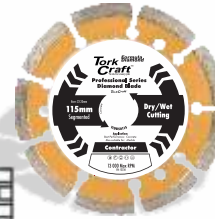

TCDB50115

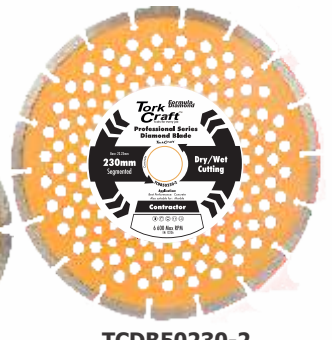

TCDB50230-2

Uni-Eco Diamond Blades

Part No.	Description
TCDB30115	115mm Segmented Diamond Blade for Concrete with Reinforcing
TCDB30230	230mm Segmented Diamond Blade for Concrete with Reinforcing



INDUSTRIAL



D-TECH Diamond Blades

Part No.	Diameter	Bore / Bushings	RPM
Continuous			
DT10115-1	115mm	22.23mm	13300
DT10115-3	115mm	22.23mm	13300
DT10230-3	230mm	22.23mm	6600
Segmented			
DT20115-1	115mm	22.23mm	13300
DT20115-2	115mm	22.23mm	13300
DT20115-3	115mm	22.23mm	13300
DT20230-1	230mm	22.23mm	6600
DT20230-3	230mm	22.23mm	6600
2 Pack			
DT20230-115	230 + 115mm	22.23mm	13300/6600

CONTRACTOR



Ceramic tiles, natural stone slabs

See Application Chart on Pg 21



DT20230-3

DT20230-115



DT20115-1



DT20115-2



DT10115-3

DeiRock Diamond



Building Materials



Ceramic Tiles

See Application Chart on Pg 21

Application : General building material and tiles (continuous rim)

Part No.	Diameter	Bore / Bushings	RPM
Continuous			
TS10115	115mm	22.23mm	13300
TS10230	230mm	22.23mm	6600
Segmented			
TS20115	115mm	22.23mm	13300
TS20230	230mm	22.23mm	6600
Turbo			
TS40115	115mm	22.23mm	13300
TS40230	230mm	22.23mm	6600



TS10230

TS10115



TS40230

TS40115



TS20230



CODE : TS20230

Pinnacle



Building Materials



Ceramic Tiles

See Application Chart on Pg 21

Application: General building material and tiles (continuous rim)

Part No.	Diameter	Bore / Bushings	RPM	
Continuous				
TW10115	115mm	22.23mm	13300	
TW10230	230mm	22.23mm	6600	
Segmented				
TW20115	115mm	22.23mm	13300	
TW20115B	115mm	22.23mm	13300	10/Pack
TW20115-5P	115mm	22.23mm	13300	5/Pack
TW20230	230mm	22.23mm	6600	
TW20230B	230mm	22.23mm	6600	10/Pack
Turbo				
TW40115	115mm	22.23mm	13300	
TW40230	230mm	22.23mm	6600	

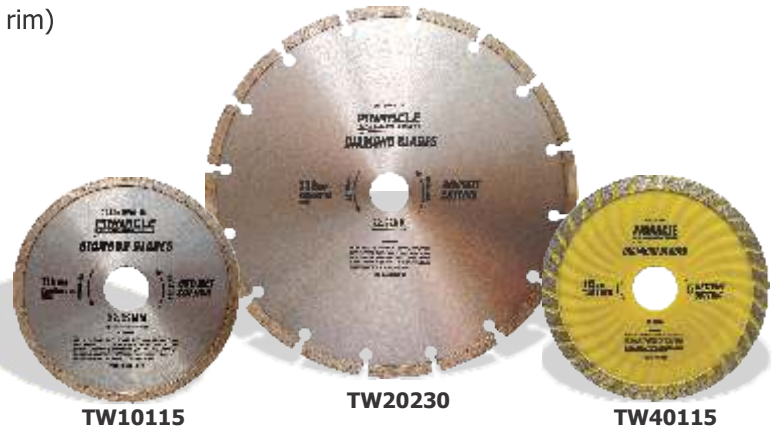

TW10115

TW20230

TW40115



TW11501



TW20115-5P



TW20115B

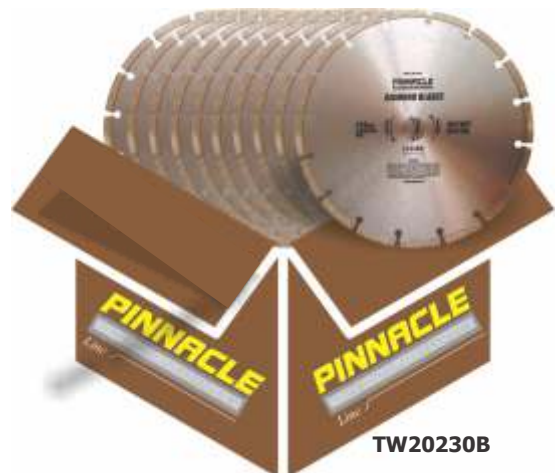

TW20230B



Diamond Polishing Sets

Part No.	Grit	Size	Colour	
TCDP10050	50	100mm	Grey	For WET use
TCDP10150	150	100mm	Yellow	For WET use
TCDP10300	300	100mm	Orange	For WET use
TCDP10500	500	100mm	Red	For WET use
TCDP11000	1000	100mm	Dark Green	For WET use
TCDP12000	2000	100mm	Pink	For WET use
TCDP13000	3000	100mm	Light Green	For WET use

INDUSTRIAL



TCDP10007 : 7 Pce Diamond Granite & Stone Polishing Set
 Contents : #50, #150, #300, #500, #1000, #2000, #3000
 Recommended Tork Craft Backing pads;
 SPC00117 - 100mm x M14 for Stone Polishing super pads Hook & Loop
 SPC00118 - 100mm x 5/8" UNC for Stone Polishing super pads Hook & Loop

Part No.	Grit	Size	Colour	
TCDP20050	50	100mm	Grey	For DRY use
TCDP20150	150	100mm	Yellow	For DRY use
TCDP20300	300	100mm	Orange	For DRY use
TCDP20500	500	100mm	Red	For DRY use
TCDP21000	1000	100mm	Light Green	For DRY use
TCDP22000	2000	100mm	Dark Green	For DRY use
TCDP33000	3000	100mm	Pink	For DRY use

INDUSTRIAL

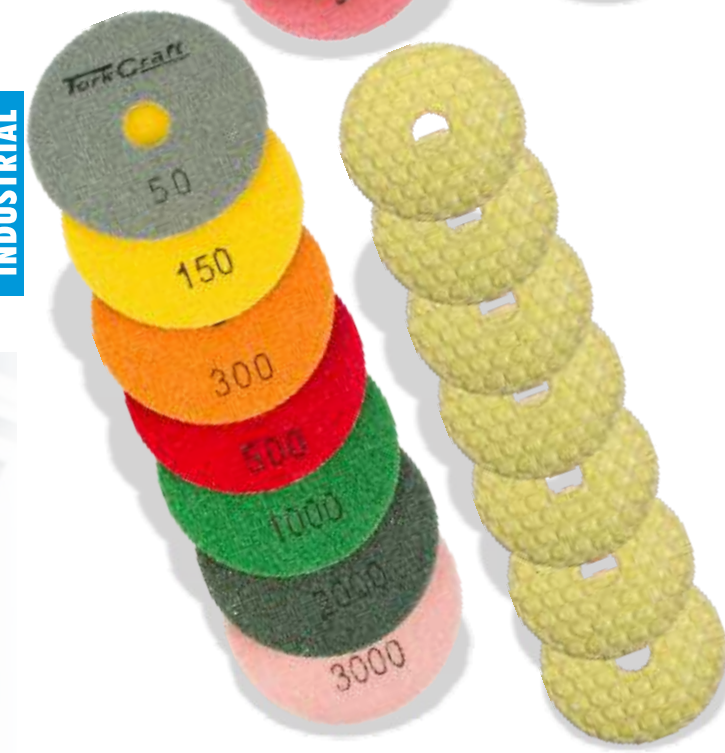

TCDP20007 : 7 Pce Diamond Polishing Pads : FOR DRY USE
 Contents : #50, #150, #300, #500, #1000, #2000, #3000
 Recommended Tork Craft Backing pads;
 SPC00117 - 100mm x M14 for Stone Polishing super pads Hook & Loop
 SPC00118 - 100mm x 5/8" UNC for Stone Polishing super pads Hook & Loop



SPC00117





HOLE SAW SYSTEMS PRODUCT KNOWLEDGE

Bi-Metal Hole Saws: heavy duty cutting in wood, plastic and machinable metal. Ideal for plumbers, mechanics, electricians and other heavy users.

Super hard high speed steel teeth cut fast

Strong electron beam weld

Knock out holes for plug removal

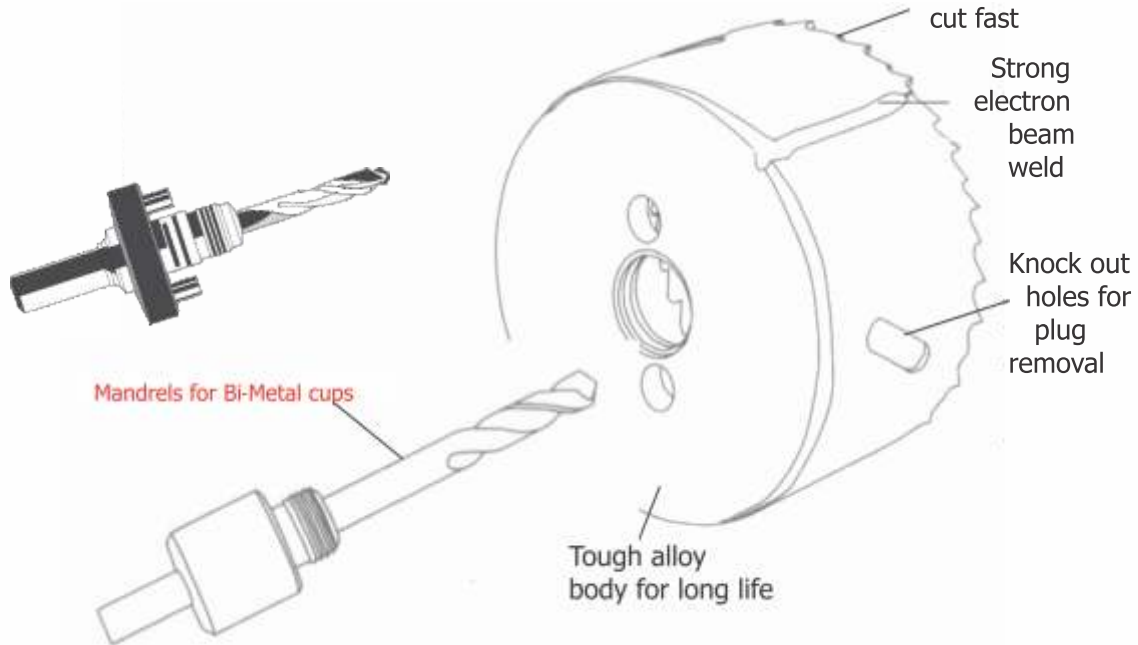

Use and Care Information

Lubricants (prolongs the lifespan of the cutting edges)

Use a good cutting oil for faster, more efficient cutting in ferrous metals.

Do not use cutting oil when cutting cast iron. Paraffin or beeswax is frequently used when cutting aluminium.

Work Piece position

Do not enter the work piece at an angle. It is important to have all the saw teeth in contact with the material to avoid tooth damage.

Feeds

Hole saws require a level, even pressure to saw efficiently. Excessive pressure will contribute to premature wear, dulling of teeth and tooth breakage. When cutting thick material, the saw should be removed from the cut at intervals to allow for chip clearances.

	Cast Iron	Hard Metals	E.G. Pipes	Cement Board	GRP	Wood	Tiles	Dry Wall	Building Blocks	Concrete Paving	House Brick	Slate	Wood Laminate
Bi-M Series TC128	✓✓	✓✓	✓✓	✓	✓	✓	✗	✗	✗	✗	✗	✗	✓
TCG Series TC038	✗	✗	✓	✓✓	✓✓	✓✓	✓✓	✓✓	✓✓	✓✓	✓✓	✓✓	✓✓

Bi-M = Bi Metal Holesaw Blade
TCG = Tungsten Carbide Grit Holesaw

Bi-Metal Hole Saw Operating Speeds

OPERATING SPEEDS & IMPORTANT R/MIN						
DIAMETER	MILD STEEL	STAINLESS STEEL	CAST IRON	BRASS	ALUMINIUM	WOOD
14	580	300	400	790	900	3000
16	550	275	365	730	825	3000
17	500	250	330	665	750	3000
19	460	230	300	600	690	3000
20	435	240	290	580	660	3000
21	425	210	280	560	635	3000
22	390	195	260	520	585	3000
24	370	185	245	495	555	3000
25	350	175	235	470	525	2700
27	325	160	215	435	480	2700
29	300	150	200	400	450	2700
30	285	145	190	380	425	2400
32	275	140	180	360	410	2400
33	260	135	175	345	390	2400
35	250	125	165	330	375	2400
37	240	120	160	315	360	2400
38	230	115	150	300	345	2400
40	220	110	145	290	330	2100
41	210	105	140	280	315	2100
43	205	100	135	270	305	2100
44	195	95	130	260	295	2100
46	190	95	125	250	285	2100
48	180	90	120	240	270	2100
51	170	85	115	230	255	2000
52	165	80	110	220	245	2000
54	160	80	105	210	240	2000
57	150	75	100	200	225	2000
59	145	75	100	195	225	2000
60	140	70	95	190	220	2000
64	135	65	90	180	205	1800
65	130	65	85	175	200	1800
67	130	65	85	170	195	1800
68	130	65	85	170	195	1800
70	125	60	80	160	185	1800
73	120	60	80	160	180	1800
76	115	55	75	150	170	1500
79	110	55	70	140	165	1500
83	105	50	70	140	155	1500
86	100	50	65	130	150	1200
89	95	45	65	130	145	1200
92	95	45	60	120	140	1200
95	90	45	60	120	135	1200
98	90	45	60	120	135	1200
102	85	40	55	110	130	1000
105	80	40	55	110	120	1000
108	80	40	55	110	120	900
111	80	40	50	100	120	900
114	75	35	50	100	105	900
121	70	35	45	95	95	900
127	65	30	45	90	90	800
133	65	30	45	90	90	800
140	60	25	40	85	85	800
146	60	25	40	85	85	800
152	55	25	35	75	75	800

USER INSTRUCTIONS

For safe use of hole saws use the correct rotation speed. The correct speed for each size is given in the table.

For longer saw life and lower operating costs, the following recommendations need to be observed.

1. Use the correct arbor for the size saw to be used.
2. Use pin-type arbors for hole saws larger than 32. When mounting, lift the pins up and then screw the arbor down into the hole saw as far as it will go, then fit the drive pins into the pin holes in the hole saw.
3. Use the correct rotation speed! Speeds that are too high or too low will decrease the life of the cutting edge.
4. Clear away wood chips or iron filings frequently in order to prevent overheating.

Bi-metal hole saws with variable pitch (Vario)

- The Vario pitch guarantees;
- Low vibration thus less heat build-up when cutting = longer edge life
 - Higher truth of running
 - Even cut
 - Depth of cut up to a maximum of 38mm

Field of application and operative range

- Electricians, heating fitters and sanitary plumbers, metal working
- For hand drills and upright drilling machines

Field of application

- Steel non ferrous heavy metal and light metal, casting, wood with nails, plywood panels, gypsum plaster board and synthetic material.

Application notes

- to achieve a perfect saw cut, please observe the rotational speed table
- use coolant (cutting oil for metals)
- make sure that chippings and shavings are removed regularly in order to prevent overheating of the hole saw.

HSS Bi-Metal Industrial Hole Saws



Part No.	Size	Part No.	Size
TC12001	14mm	TC12029	59mm
TC12002	16mm	TC12030	60mm
TC12003	17mm	TC12031	64mm
TC12004	19mm	TC12032	65mm
TC12005	20mm	TC12033	67mm
TC12006	21mm	TC12034	68mm
TC12007	22mm	TC12035	70mm
TC12008	24mm	TC12036	73mm
TC12009	25mm	TC12037	76mm
TC12010	27mm	TC12038	79mm
TC12011	28mm	TC12039	83mm
TC12012	29mm	TC12040	86mm
TC12013	30mm	TC12041	89mm
TC12014	32mm	TC12042	92mm
TC12015	33mm	TC12043	95mm
TC12016	35mm	TC12044	98mm
TC12017	37mm	TC12045	102mm
TC12018	38mm	TC12046	105mm
TC12019	40mm	TC12047	108mm
TC12020	41mm	TC12048	111mm
TC12021	43mm	TC12049	114mm
TC12022	44mm	TC12050	121mm
TC12023	46mm	TC12051	127mm
TC12024	48mm	TC12052	133mm
TC12025	51mm	TC12053	140mm
TC12026	52mm	TC12054	146mm
TC12027	54mm	TC12055	152mm
TC12028	57mm		

INDUSTRIAL



HSS BiM42 Industrial Hole Saws



Part No.	Size	Part No.	Size
TC12101	14mm	TC12129	59mm
TC12102	16mm	TC12130	60mm
TC12103	17mm	TC12131	64mm
TC12104	19mm	TC12132	65mm
TC12105	20mm	TC12133	67mm
TC12106	21mm	TC12134	68mm
TC12107	22mm	TC12135	70mm
TC12108	24mm	TC12136	73mm
TC12109	25mm	TC12137	76mm
TC12110	27mm	TC12138	79mm
TC12111	28mm	TC12139	83mm
TC12112	29mm	TC12140	86mm
TC12113	30mm	TC12141	89mm
TC12114	32mm	TC12142	92mm
TC12115	33mm	TC12143	95mm
TC12116	35mm	TC12144	98mm
TC12117	37mm	TC12145	102mm
TC12118	38mm	TC12146	105mm
TC12119	40mm	TC12147	108mm
TC12120	41mm	TC12148	111mm
TC12121	43mm	TC12149	114mm
TC12122	44mm	TC12150	121mm
TC12123	46mm	TC12151	127mm
TC12124	48mm	TC12152	133mm
TC12125	51mm	TC12153	140mm
TC12126	52mm	TC12154	146mm
TC12127	54mm	TC12155	152mm
TC12128	57mm		

INDUSTRIAL

HSS Bi-Metal Hole Saws

For cutting metal, wood and PVC, Packaged

- » Ideal for electricians, plumbers, mechanics & other heavy duty users
- » Flexible, shatter resistant body reduces breakage
- » Lasts up to 5 times longer than standard hole saws
- » Precision sharpened teeth for smooth, fast cuts
- » 38mm depth of cut
- » Fits standard mandrels



HSS BiM42 Hole Saws

For cutting stainless steel (Nirosta), mild steel/Iron, Aluminium, PVC & Wood

- » Improved chip clearance
 - » BiM42 Cobalt Steel
 - » Alternating Tooth Pattern
 - » Variable pitch teeth reduce harmonic vibration
- » Material release slots to clear material efficiently
- » Ultra-thin kerf for accurate cuts
 - » 38mm cut depth for all sizes
 - » Use mandrel TC17002, TC17003, TC17007



HSS Hole Saws



Part No.	Size	INDUSTRIAL
TC28012	Hole Saw 12mm	
TC28013	Hole Saw 13mm	
TC28014	Hole Saw 14mm	
TC28016	Hole Saw 16mm	
TC28017	Hole Saw 17mm	
TC28018	Hole Saw 18mm	
TC28019	Hole Saw 19mm	
TC28020	Hole Saw 20mm	
TC28022	Hole Saw 22mm	
TC28024	Hole Saw 24mm	
TC28025	Hole Saw 25mm	
TC28028	Hole Saw 28mm	
TC28030	Hole Saw 30mm	
TC28032	Hole Saw 32mm	
TC28035	Hole Saw 35mm	
TC28038	Hole Saw 38mm	
TC28040	Hole Saw 40mm	
TC28042	Hole Saw 42mm	



Part No.	Size	INDUSTRIAL
TC28045	Hole Saw 45mm	
TC28048	Hole Saw 48mm	
TC28050	Hole Saw 50mm	
TC28055	Hole Saw 55mm	
TC28060	Hole Saw 60mm	
TC28064	Hole Saw 64mm	
TC28070	Hole Saw 70mm	
TC28075	Hole Saw 75mm	
TC28080	Hole Saw 80mm	

Part No.	Size	INDUSTRIAL
HSS Arbor Drills		
TC28650	HSS Arbor Drill 6x50mm	
TC28860	HSS Arbor Drill 8x60mm	

High Speed Steel Holesaws

- Especially designed for sheet metal up to 5mm thickness.
- Ideal for sheet metal, alloy steel, aluminium, brass plate and F.R.P.
- Fits portable electric drills and drill presses.

TCT Hole Saws



Part No.	Description	RPM	INDUSTRIAL
TC915001	TCT Hole Saw 16mm	796	
TC915004	TCT Hole Saw 19mm	750	
TC915005	TCT Hole Saw 20mm	720	
TC915006	TCT Hole Saw 22mm	690	
TC915010	TCT Hole Saw 25mm	690	
TC915015	TCT Hole Saw 30mm	660	
TC915016	TCT Hole Saw 32mm	645	
TC915020	TCT Hole Saw 35mm	630	
TC915023	TCT Hole Saw 38mm	600	
TC915025	TCT Hole Saw 40mm	590	
TC915030	TCT Hole Saw 45mm	550	
TC915035	TCT Hole Saw 50mm	420	
TC915040	TCT Hole Saw 55mm	370	
TC915041	TCT Hole Saw 60mm	300	
TC915043	TCT Hole Saw 64mm	270	
TC915044	TCT Hole Saw 65mm	260	
TC915045	TCT Hole Saw 70mm	220	
TC915046	TCT Hole Saw 75mm	183	
TC915047	TCT Hole Saw 80mm	173	
TC915048	TCT Hole Saw 83mm	171	
TC915049	TCT Hole Saw 90mm	152	
TC915051	TCT Hole Saw 100mm	137	



14.5mm Depth of cut

TCT Holesaws

- » Especially designed for hard materials up to 14.5mm thickness
- » With it's extremely sharp TCT cutting edges it can be run at higher speeds for holes of exceptional quality & accuracy
- » For portable drills and drill presses.
- » Ideal for sheet metal, stainless steel, steel pipes, F.R.P, aluminium, vinyl and plastic.
- » Use with cutting fluid TC OIL for best results.

Diamond Grit Hole Saws



Part No.	Description & Size	INDUSTRIAL NO HAMMER
TC17002-3	Mandrel / Diamond Hole Saw 14 - 30mm	
TC17007-3	Mandrel / Diamond Hole Saw 32 - 152mm	
TC29015	Hole Saw Diamond 15mm	
TC29022	Hole Saw Diamond 22mm	
TC29025	Hole Saw Diamond 25mm	
TC29030	Hole Saw Diamond 30mm	
TC29032	Hole Saw Diamond 32mm	
TC29035	Hole Saw Diamond 35mm	
TC29040	Hole Saw Diamond 40mm	
TC29050	Hole Saw Diamond 50mm	

Technical Specifications

- Specially designed for glass, reinforced plastics, granite, marble, slate, tiles & other extremely hard and abrasive materials.
- Depth of cut = 38mm

No Hammer action



TC17002-3

Sheet Metal Punch - Chassis Punch



Sheet Metal



Mild Steel

For clean holes **FAST**
in sheet metal up to 1.625mm mild steel

Part No.	Description	INDUSTRIAL
TCCP016	Chassis - Screw - Sheet Metal Punch 16mm	
TCCP020	Chassis - Screw - Sheet Metal Punch 20mm	
TCCP022	Chassis - Screw - Sheet Metal Punch 22mm	
TCCP025	Chassis - Screw - Sheet Metal Punch 25mm	
TCCP0254	Chassis - Screw - Sheet Metal Punch 25.4mm	
TCCP030	Chassis - Screw - Sheet Metal Punch 30mm	
TCCP032	Chassis - Screw - Sheet Metal Punch 32mm	
TCCP035	Chassis - Screw - Sheet Metal Punch 35mm	
TCCP038	Chassis - Screw - Sheet Metal Punch 38mm	
TCCP040	Chassis - Screw - Sheet Metal Punch 40mm	
TCCP050	Chassis - Screw - Sheet Metal Punch 50mm	
TCCP054	Chassis - Screw - Sheet Metal Punch 54mm	



Tungsten Grit Hole Saws



Stonework (Brick)



Fibreglass



Hard & Softwood



Ceramic Tiles

Part No.	Description & Size	NO HAMMER INDUSTRIAL
TC17002	Mandrel 3/8" Hex 14 - 30mm	
TC17002-2	Carbide / Diamond Hole Saw 14 - 30mm	
TC17007	Mandrel 7/16" Hex 32 - 178mm with pins	
TC17007-2	Carbide / Diamond Hole Saw 32 - 152mm	
TC03016	Carbide Grit 16mm Blister card	
TC03020	Carbide Grit 20mm Blister card	
TC03022	Carbide Grit 22mm Blister card	
TC03025	Carbide Grit 25mm Blister card	
TC03029	Carbide Grit 29mm Blister card	
TC03032	Carbide Grit 32mm Blister card	
TC03035	Carbide Grit 35mm Blister card	
TC03038	Carbide Grit 38mm Blister card	
TC03044	Carbide Grit 44mm Blister card	
TC03051	Carbide Grit 51mm Blister card	
TC03054	Carbide Grit 54mm Blister card	
TC03057	Carbide Grit 57mm Blister card	
TC03064	Carbide Grit 64mm Blister card	
TC03070	Carbide Grit 70mm Blister card	
TC03073	Carbide Grit 73mm Blister card	
TC03076	Carbide Grit 76mm Blister card	
TC03083	Carbide Grit 83mm Blister card	
TC03086	Carbide Grit 86mm Blister card	
TC03092	Carbide Grit 92mm Blister card	
TC030111	Carbide Grit 111mm Blister card	

Technical Specifications

- Stable body made of special alloy toolsteel band, edges are carbide gritted
- The carbide grit is almost as hard as diamond - the saws remain sharp for longer and therefore have the longest edge life
- No interlocking or breaking off because of carbide metal surface
- Fast, aggressive cut on many materials, with very little effort
- Depth of cut = approximately 40mm
- Arbors must be used on bi-metal & carbide grit holesaws

Operative range

- For hard and abrasive materials such as fibreglass, Kevlar, asbestos, graphite, carbon, brick, tiles, plaster slabs, walls, light stones, wood and weather board.
- For wall sockets and all diameters of pipes.

No Hammer action



Part No.	Description & Size
TC17002	HSS Mandrel 9.5mm Hex for sizes 14 - 30mm
TC17003	Mandrel 14 - 152mm Quick Change w/11mm Hex Shank c/w 1/4" HSS pilot & 2 x Adaptors
TC17003-1	Mandrel Repl. Adaptor 14-30mm for TC17003
TC17003-2	Mandrel Repl. Adaptor 32-152mm for TC17003
TC17004	HSS Mandrel 7/16" Hex for sizes 32 - 44mm
TC17007	HSS Mandrel 12mm Hex for sizes 32 - 152mm w/pins
TC17007-4	Mandrel TCT Hole Saw 7/16" 32 - 152mm
TC17009	HSS Mandrel SDS Shank for sizes 32 - 178mm w/pins
TC17015	Adaptor for mandrel 17004
TC17016	Allen key for mandrel
TC00001	Replacement drill for mandrel 6.35 x 115 - Extra long
TC00002	Replacement drill for mandrel 6.35 x 70
TC00003	Replacement drill bit for 915 Series Hole Saws
TC00004	Replacement drill bit for Carbide Grit Hole saws
TC00005	Aluminium base for Carbide Grit Hole saws
TC00006	Replacement drill bit for TC17007-3 Mandrel

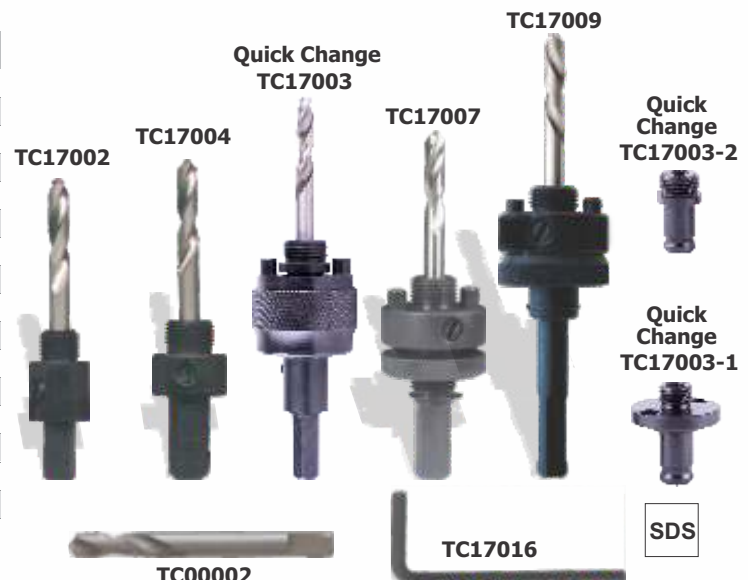

Carbon Steel Hole Saws



Part No.	Size	Use Mandrel	Part No.	Size	Use Mandrel
TC911001	19mm	TC917009	TC911012	54mm	TC917012
TC911002	22mm	TC917009	TC911013	57mm	TC917012
TC911003	25mm	TC917009	TC911014	60mm	TC917012
TC911004	28mm	TC917009	TC911015	64mm	TC917012
TC911005	32mm	TC917012	TC911016	67mm	TC917012
TC911006	35mm	TC917012	TC911017	70mm	TC917012
TC911007	38mm	TC917012	TC911018	73mm	TC917012
TC911008	41mm	TC917012	TC911019	76mm	TC917012
TC911009	44mm	TC917012	TC911020	82mm	TC917012
TC911010	48mm	TC917012	TC911021	86mm	TC917012
TC911011	51mm	TC917012			

Carbon Steel Hole Saws

- Ideal for cutting wood, composite materials and plastic
- Not for use on metal or steel
- 19mm depth of cut

Part No.	Size
TC917009	Mandrel for sizes 19 - 28mm
TC917012	Mandrel for sizes 32 - 86mm



Drive Plate

PART NO. TCDP001
Drive Plate (Black)

Packaged in double blister & carded

» Support plate for carbon steel hole saws larger than 64mm.

» Use with mandrel #TC917012



TORK CRAFT™ Dry Cut Diamond Core Drills



Brickwork	Thread	Size	Concrete	Thread	Size
TC180038	16mm	38 x 170mm	TC180038-2	22mm	38 x 170mm
TC180052	16mm	52 x 170mm	TC180052-2	22mm	52 x 170mm
TC180065	16mm	65 x 170mm	TC180065-2	22mm	65 x 170mm
TC180075	16mm	75 x 170mm	TC180075-2	16mm	75 x 170mm
TC180078	16mm	78 x 170mm	TC180117-3	16mm	117 x 150mm
TC180117	16mm	117 x 170mm	TC180117-2	22mm	117 x 170mm
TC180078-1	22mm	78 x 170mm - Universal			

NO HAMMER



For cutting large diameter holes, quickly and neatly

Part No.	Description
TC18HEX1	Hex Shank Adaptor - 70mm M16 (Pilot drill not included)
TC18HEX2	Hex Shank Adaptor - 200mm M16 (Pilot drill not included)
TC18HEX3	Hex Shank Adaptor - 300mm M16 x 13mm (Pilot drill not incl)
TC18SDS1	SDS Plus Adaptor - 70mm M16 (Pilot drill not included)
TC18SDS2	SDS Plus Adaptor - 200mm M16 (Pilot drill not included)
TC18SDS3	SDS Adaptor - 300mm M16 (Pilot drill not included)
TC18SDS4	SDS Adaptor - 70mm M22 (Pilot drill not included)
TC18SDS5	SDS Adaptor - 200mm M22 (Pilot drill not included)
TC18SDS6	SDS Adaptor - 300mm M22 (Pilot drill not included)
TC18SDS7	SDS Adaptor MAX - 300mm M22 (Pilot drill not included)
TC18KEY	Drift Key for TC18 Diamond Core Bits
TC18PILOT	Pilot Drill Bit

NO HAMMER



Part No. TC180501
10 Pce Set - Diamond Core Bits
Sizes: 38, 52, 65 & 117mm

Ideal Set for Builders & Plumbers

NB!
NOT FOR
RE-INFORCED
DRILLING IN CONCRETE!

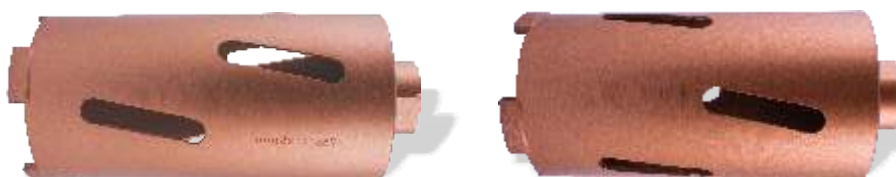

TCT Hollow Core Bits & Adaptors



Brick & Masonry

For cutting clean holes in brick and aerated block

Part No.	Description & Size
TC322201	TCT Hollow Core Bit 30 x 72mm M22
TC322202	TCT Hollow Core Bit 35 x 72mm M22
TC322203	TCT Hollow Core Bit 40 x 72mm M22
TC322204	TCT Hollow Core Bit 45 x 72mm M22
TC322205	TCT Hollow Core Bit 50 x 72mm M22
TC322232	TCT Hollow Core Bit 52 x 72mm M22
TC322206	TCT Hollow Core Bit 55 x 72mm M22
TC322207	TCT Hollow Core Bit 60 x 72mm M22
TC322208	TCT Hollow Core Bit 65 x 72mm M22
TC322209	TCT Hollow Core Bit 70 x 72mm M22
TC322230	TCT Hollow Core Bit 75 x 72mm M22
TC322210	TCT Hollow Core Bit 80 x 72mm M22
TC322211	TCT Hollow Core Bit 90 x 72mm M22
TC322212	TCT Hollow Core Bit 100 x 72mm M22
TC322213	TCT Hollow Core Bit 110 x 72mm M22
TC322214	TCT Hollow Core Bit 125 x 72mm M22

INDUSTRIAL



Part No.	Description & Size
ADAPTORS 110mm	
TC322215	SDS Plus Adaptor 110mm x M16
TC322237	SDS Plus Adaptor 110mm x M22
TC322239	Hex Adaptor 110mm x M22
TC322216	110mm x M14 SDS Plus Adaptor
ADAPTORS 200mm	
TC322218	SDS Plus Adaptor 200mm x M16
TC322219	13mm Hex Adaptor 200mm x M16
TC322222	SDS Max Adaptor 200mm x M16
TC322225	SDS Plus Adaptor 200mm x M22
TC322240	13mm Hex Adaptor 200mm x M22
ADAPTORS 300mm	
TC322223	SDS Plus Adaptor 300mm x M16
TC322228	SDS Plus Adaptor 300mm x M22
TC322241	Hex Adaptor 300mm x M22
TC322243	SDS Max Adaptor 300mm x M22
ADAPTORS 400mm	
TC322233	SDS Plus Adaptor 400mm x M22
TC322234	SDS Max Adaptor 400mm x M22
TC317888	SDS Max Adaptor 400mm x M22
ADAPTORS 450mm	
TC322238	SDS Plus Adaptor 450mm x M22
TC322242	13mm Hex Adaptor 450mm x M22

Part No.	Description & Size
DRILL BITS	
TC322217	Pilot Centre Drill Bit for TC322 Core Bits
TC322229	Centre Drill Bit - Tapered shank
Pilot Pin	
TC323999	Pilot Drill to fit TC323 Series 150mm

Part No.	Description & Size
TC323040	TCT Hollow Core Bit LONG 40 x 150mm M22
TC323050	TCT Hollow Core Bit LONG 50 x 150mm M22
TC323055	TCT Hollow Core Bit LONG 55 x 150mm M22
TC323060	TCT Hollow Core Bit LONG 60 x 150mm M22
TC323065	TCT Hollow Core Bit LONG 65 x 150mm M22
TC323070	TCT Hollow Core Bit LONG 70 x 150mm M22
TC323080	TCT Hollow Core Bit LONG 80 x 150mm M22
TC323110	TCT Hollow Core Bit LONG 110 x 150mm M22

INDUSTRIAL

Series TC323

- » Longer length body
- » Minimize cleaning of core
- » Can drill through a standard single wall without core cleaning
- » Comes with pilot drill bit & arbor
- » Hammer action can cause adaptor breakage



Carbon Steel Hole Saw Sets



PART NO. TCHSK013

13pce Hole Saw Set

Hole saws 19, 22, 25, 29, 32, 38, 44, 51 & 64mm

2 x Arbors, 1 x Hex wrench, 1 x Wood flat bit 25mm

Packaged in blow case and double blister

- Cuts smooth, clean, accurate through holes up to 25mm thick in wood, plastics and other soft materials

- **Not for use on metal or steel**



PART NO. TCHSK015

15pce Hole Saw Set

Hole saws 19, 22, 25, 28, 32, 35, 38, 44, 51, 57,

64 & 76mm, 2 x Arbors, 1 Hex wrench

Packaged in blow case and double blister

- Cut smooth, clean, accurate through holes up to 25mm thick in wood, plastics & other soft material

- **Not for use on metal or steel**



PART NO. TC911032

5 Pce Carbon Steel Hole Saw Set

Hole saws 32, 38, 44 & 54mm

plus 1 x Mandrel

- Packaged in Blister

- Cuts smooth, clean accurate through holes up to 25mm thick in wood, plastics and other soft material

- **Not for use on metal or steel**



PART NO. TC911048

16 Pce Master Hole Saw Kit

Hole saws 19, 22, 29, 32, 38, 44 51,

64, 76, 89, 102 & 127mm

2 x Arbors, 1 x Hex wrench & 1 x Drive plate

- Cuts smooth, clean accurate through holes

up to 25mm thick in wood, plastics and

other soft material

- **Not for use on metal or steel**



PART NO. TC911049

3 Pce Lock Installation Kit

Contains: 1 x 54mm Hole saw, 1 x 25mm Spade bit plus 1 x Hole saw mandrel

For 54mm dead bolts or lock-sets with a 25mm latch hole

Installs: Yale, Kwikset, Weslock, Schlage, Dexter, National,

Sargent, Accord, E-Z Sets & others

Not for use on metal or steel



Part No. TCCC30200

Circle Hole Cutter

Adjustable 30 - 200mm

Cuts smooth clean accurate through holes up to 30mm in plywood, laminates, composite boards, gypsum board, plastic, rubber and a wide range of other materials

HSS Bi-Metal Industrial Hole Saw Sets



PART NO. TCHSK006
6 Pce Bi-Metal Hole Saw Set
Contains: Hole saws 22, 25, 32, 35 & 51mm
1 x 3/8" Hex Mandrel
Packaged in blow mould case



PART NO. TCHSK09E-1
9 Pce Bi-Metal Hole Saw Set
Contains: Hole saws 16, 20, 25, 32, 40 & 51mm
2 x Arbor & 1 x Adaptor
Packaged in aluminium case



PART NO. TCHSK09E
9 Pce Bi-Metal Hole Saw Set
Contains: Hole saws 22, 29, 35, 44, 51 & 64mm
2 x Arbor & 1 x Adaptor
Packaged in blow mould case and double blister



PART NO. TCHSK09P
9 Pce Bi-Metal Hole Saw Set
Contains: Hole saws 19, 22, 29, 38, 44 & 57mm
2 x Arbor & 1 x Adaptor
Packaged in blow mould case and double blister



PART NO. TCHSK13J
13 Pce Bi-Metal Hole Saw Set
Contains: Hole saws 19, 22, 29, 35, 38, 44, 54, 57 & 64mm
1 x Hex Key, 2 x Arbor
Packaged in blow mould case and double blister

Carbon Steel Hole Saw Sets



PART NO. TCDK6
6 Pce Carbon Steel Downlighter Set
- Hole saws 51, 60, 64, 72, 75 & 86mm
- 1 x Pilot Drill, 1 x Hex Key, 1 x Arbor
- Packaged in blow mould case
- Large sizes for cable management & electrical fittings
- Hardened and tempered alloy steel for long life
- Not for use on metal or steel



PART NO. TCDK009
9 Pce Carbon Steel Downlighter Set
- Hole saws 50, 60, 65, 72, 75 & 86mm
- 1 x Hex Wrench, 1 x Arbor, 1 x Drive plate
- Packaged in blow mould case
- Cuts smooth, clean accurate through holes up to 25mm thick in wood, plastics & other soft material
- Not for use on metal or steel



PART NO. TCDK17
17 Pce Downlighter Installers Kit with Drill Saws
Hole saws 19, 22, 29, 32, 38, 44, 51, 64mm plus 1 x 9.5mm Mandrel, 1 x 6.35mm Mandrel, 1 x 2.5mm Hex key wrench
Packaged in blow mould case and double blister
- Not for use on metal or steel



Magnetic Core Drills



**NEW
PRODUCT**

TCMD0035HD

Magnetic Core Drill

- * Cutters not included
- » Core Drill Diameter : 35mm
- » Power : 1550W
- » No-load Speed : 100 - 830RPM
- » Maximum Attraction : 14,800Nm
- » Voltage : 110/220V
- » Rate Frequency : 50 - 60Hz



**NEW
PRODUCT**

TCMD0035PM

Permanent Magnetic Core Drill

- * Cutters not included
- » Core Drill Diameter : 35mm
- » Power : 1600W
- » No-load Speed : 810RPM
- » Maximum Attraction : 16,000Nm
- » Voltage : 220V



**NEW
PRODUCT**

TCMD0035QE

Auto Magnetic Core Drill

- * Cutters not included
- » Core Drill Diameter : 35mm
- » Power :
- » No-load Speed : 760RPM
- » Maximum Attraction : 16,000Nm
- » Voltage : 220V



**NEW
PRODUCT**

TCMD0035WO

Magnetic Core Drill

- * Cutters not included
- » Core Drill Diameter : 35mm
- » Power :
- » No-load Speed : 100 - 810RPM
- » Maximum Attraction : 16,000Nm
- » Voltage : 110/220V
- » Rate Frequency : 50 - 60Hz



**NEW
PRODUCT**

TCMD0055QE

Auto Magnetic Core Drill

- * Cutters not included
- » Core Drill Diameter : 55mm
- » Power :
- » No-load Speed : 100 - 420RPM
- » Maximum Attraction : 16,500Nm
- » Voltage : 110/220V
- » Rate Frequency : 50 - 60Hz

TCMD0050HD

Magnetic Core Drill

- * Cutters not included
- » Core Drill Diameter : 50mm
- » Power :
- » No-load Speed : 100 - 810RPM
- » Maximum Attraction : 15,600Nm
- » Voltage : 110/220V
- » Rate Frequency : 50 - 60Hz



**NEW
PRODUCT**

TCMD0068HD

Magnetic Core Drill

- * Cutters not included
- » Core Drill Diameter : 60mm
- » Twist Drill Diameter : 23mm
- » Power : 1890W
- » No-load Speed : 100 - 440RPM
- » Maximum Attraction : 16,000Nm
- » Voltage : 110/220V
- » Rate Frequency : 50 - 60Hz



**NEW
PRODUCT**

ANNULAR CUTTERS PRODUCT KNOWLEDGE



Stainless Steel



Mild Steel

Cutting holes in tube and pipe poses a few problems. These problems can be overcome by the use of an ANNULAR CUTTER. Due to the annular cutter being hollow there is no "dead zone" (as in the use of a twist drill), so dimpling and deburring are avoided, as is the deforming of the material. The use of a regular twist drill causes concerns with centering and hole location, hole roundness, hole finish, stock deformation, burrs and jagged edges of stock, and duration of operation.

Using ANNULAR CUTTERS in most tube and pipe cutting applications holes can be drilled without pre-spotting the location. Annular cutters require a smaller relief angle than twist drills as they cut the material rather than ripping through it, leaving a clean, round and virtually burr-free hole. As the annular cutter trepanns the hole it leaves the centre as a solid slug and exerts minimal force on the material. The tool's multiple cutting edges distribute the load evenly resulting in fast feed rates, minimizing the thrust and horsepower needed.

Knowing how to use an ANNULAR CUTTER and what to look for can help to avoid problems and extend tool life. The annular cutter should be used with a portable magnetic drill with pipe adaptor securely fixed and wrapped with chain.

INDUSTRIAL

Q & A

- 1. What causes Annular Cutters to break or dull prematurely?**
Primarily a feed rate which is too slow. Using a firm, steady feed pressure throughout the cut will maximize performance and extend tool life.
- 2. Why should chips be cleared before each cut?**
As the cutter begins removing material, new chips flow out through the gullets and up the flutes. If these pathways are not cleared before each new hole is cut, packing or binding may result, causing the cutter to fill with chips and possibly break.
- 3. When should a magnetic drill be used?**
Jockeying a large pipe into position on a stationary drill is awkward – a portable magnetic drill takes the tool to the workpiece. A portable magnetic drill press may also be used in any position – vertical, horizontal, or overhead. The workpiece must be at least 3/8" thick.
- 4. Is the magnet on the portable drill press strong enough to drill pipe?**
When using a portable drill press a support system is needed. A safety chain or strap is recommended. When using a magnetic drill and pipe adaptor accessory, mount the adaptor securely to the pipe with a tightly wrapped chain. Make sure the support system for the drill arbor is rigid and in good condition.
- 5. How is the magnetic drill kept from slipping?**
The magnetic drill base should be kept clear of chips and debris and securely attached to a clean work place. Uneven surfaces or large debris buildup prevent the magnet from obtaining optimum hold, which may cause the drill to shift or lift during operation.
- 6. What makes the slug stick in the cutter?**
Using a lubricant or cutting fluid makes the slug easier to eject at the end of a cut. But, if the slug ejection becomes unreliable or the tube resists cutting, it probably means that the cutters edges are becoming dull – sharpen or replace the cutter.
- 7. Is coolant necessary?**
Always use some form or coolant when drilling to maintain cutting performance and tool life. Any form of coolant will help, even water is better than nothing. TorkCraft recommends using TC OIL for cooling.

Part No.	Size	Part No.	Size	Part No.	Size
TCAC012-1	12 x 30mm	TCAC012-2	12 x 55mm	TCAC042-1	42 x 30mm
TCAC013-1	13 x 30mm	TCAC013-2	13 x 55mm	TCAC042-2	42 x 55mm
TCAC014-1	14 x 30mm	TCAC014-2	14 x 55mm	TCAC044-1	44 x 30mm
TCAC015-1	15 x 30mm	TCAC015-2	15 x 55mm	TCAC044-2	44 x 55mm
TCAC016-1	16 x 30mm	TCAC016-2	16 x 55mm	TCAC045-1	45 x 30mm
TCAC017-1	17 x 30mm	TCAC017-2	17 x 55mm	TCAC045-2	45 x 55mm
TCAC018-1	18 x 30mm	TCAC018-2	18 x 55mm	TCAC046-1	46 x 30mm
TCAC019-1	19 x 30mm	TCAC019-2	19 x 55mm	TCAC046-2	46 x 55mm
TCAC020-1	20 x 30mm	TCAC020-2	20 x 55mm	TCAC048-1	48 x 30mm
TCAC021-1	21 x 30mm	TCAC021-2	21 x 55mm	TCAC048-2	48 x 55mm
TCAC022-1	22 x 30mm	TCAC022-2	22 x 55mm	TCAC050-1	50 x 30mm
TCAC023-1	23 x 30mm	TCAC023-2	23 x 55mm	TCAC050-2	50 x 55mm
TCAC024-1	24 x 30mm	TCAC024-2	24 x 55mm	TCAC055-1	55 X 30mm
TCAC025-1	25 x 30mm	TCAC025-2	25 x 55mm	TCAC055-2	55 x 55mm
TCAC026-1	26 x 30mm	TCAC026-2	26 x 55mm	TCAC058-1	58 x 30mm
TCAC027-1	27 x 30mm	TCAC027-2	27 x 55mm	TCAC058-2	58 x 55mm
TCAC028-1	28 x 30mm	TCAC028-2	28 x 55mm		
TCAC030-1	30 x 30mm	TCAC030-2	30 x 55mm		
TCAC031-1	31 x 30mm	TCAC031-2	31 x 55mm		
TCAC032-1	32 x 30mm	TCAC032-2	32 x 55mm		
TCAC033-1	33 x 30mm	TCAC033-2	33 x 55mm		
TCAC034-1	34 x 30mm	TCAC034-2	34 x 55mm		
TCAC035-1	35 x 30mm	TCAC035-2	35 x 55mm		
TCAC036-1	36 x 30mm	TCAC036-2	36 x 55mm		
TCAC038-1	38 x 30mm	TCAC038-2	38 x 55mm		
TCAC040-1	40 x 30mm	TCAC040-2	40 x 55mm		



TCAC0001	Tool Holder MT3 - 3/4" Weldon shank
TCAC0002	Tool Holder MT2 - 3/4" Weldon Shank
TCAC0004	Pilot Pin 6.3 x 79mm for hole cutters 30mm
TCAC0005	Pilot Pin 6.3 x 102mm for hole cutters 55mm

TCAC006	Drill Bit HSS w/Weldon Shank 6mm
TCAC008	Drill Bit HSS w/Weldon Shank 8mm
TCAC009	Drill Bit HSS w/Weldon Shank 9mm
TCAC010	Drill Bit HSS w/Weldon Shank 10mm
TCAC011	Drill Bit HSS w/Weldon Shank 11mm

Taps & Dies



HIGH SPEED STEEL TAPS

1Pce Carded	3Pce Boxed	Size	Use Drill Size
NR1030C	NR1030-3	Taps HSS 3 x 0.5mm ISO	2.5mm
NR1040C	NR1040-3	Taps HSS 4 x 0.7mm ISO	3.3mm
NR1050C	NR1050-3	Taps HSS 5 x 0.8mm ISO	4.2mm
NR1060C	NR1060-3	Taps HSS 6 x 1.0mm ISO	5.0mm
NR1080-1C		Taps HSS 8 x 1.0mm ISO	7.0mm
NR1080C	NR1080-3	Taps HSS 8 x 1.25mm ISO	6.8mm
NR1100-1C		Taps HSS 10 x 1.0mm ISO	9.0mm
NR1100-2C		Taps HSS 10 x 1.25mm ISO	8.8mm
NR1100C	NR1100-3	Taps HSS 10 x 1.5mm ISO	8.5mm
NR1120-1C		Taps HSS 12 x 1.5mm ISO	10.5mm
NR1120-2C		Taps HSS 12 x 1.25mm ISO	10.8mm
NR1120C	NR1120-3	Taps HSS 12 x 1.75mm ISO	10.2mm
NR1140-1C		Taps HSS 14 x 1.25mm ISO	12.8mm
NR1140-2C		Taps HSS 14 x 1.5mm ISO	12.5mm
NR1140C	NR1140-3	Taps HSS 14 x 2.0mm ISO	12.0mm
NR1160-1C		Taps HSS 16 x 1.5mm ISO	14.5mm
NR1160C	NR1160-3	Taps HSS 16 x 2.0mm ISO	14.0mm

INDUSTRIAL

CARBON STEEL TAPS

1Pce Carded	3Pce Boxed	Size	Use Drill Size
NR2030C	NR2030-3	Taps Carbon Steel 3 x 0.5mm	2.5mm
NR2040C	NR2040-3	Taps Carbon Steel 4 x 0.7mm	3.3mm
NR2050C	NR2050-3	Taps Carbon Steel 5 x 0.8mm	4.2mm
NR2060C	NR2060-3	Taps Carbon Steel 6 x 1.00mm	5.0mm
NR2080C	NR2080-3	Taps Carbon Steel 8 x 1.25mm	6.8mm
NR2110C	NR2110-3	Taps Carbon Steel 10 x 1.50mm	8.5mm
NR2120C	NR2120-3	Taps Carbon Steel 12 x 1.75mm	10.2mm
NR2120-1C		Taps Carbon Steel 12 x 1.25mm	10.8mm
NR2140C	NR2140-3	Taps Carbon Steel 14 x 2.00mm	12.0mm
NR2160C	NR2160-3	Taps Carbon Steel 16 x 2.00mm	14.0mm

HIGH SPEED STEEL DIES

1Pce Carded	1Pce Case	Size
NR3030C	NR3030-3	Die HSS Hex 3 x 0.50mm 1"
NR3040C	NR3040-3	Die HSS Hex 4 x 0.70mm 1"
NR3050C	NR3050-3	Die HSS Hex 5 x 0.80mm 1"
NR3060C	NR3060-3	Die HSS Hex 6 x 1.00mm 1"
NR3080C	NR3080-3	Die HSS Hex 8 x 1.25mm 1"
NR3110C	NR3100-3	Die HSS Hex 10 x 1.50mm 1"
NR3120C	NR3120-3	Die HSS Hex 12 x 1.75mm 1"
NR3140C	NR3140-3	Die HSS Hex 14 x 2.00mm 1"
NR3160C	NR3160-3	Die HSS Hex 16 x 2.00mm 1"
NR3180C	NR3180-3	Die HSS Hex 18 x 2.50mm 1"
NR3240C	NR3240-3	Die HSS Hex 24 x 3.00mm 1"

INDUSTRIAL

CARBON STEEL DIES

1Pce Carded	1Pce Case	Size
NR4030C	NR4030-3	Die Carbon Steel 3 x 0.50mm
NR4040C	NR4040-3	Die Carbon Steel 4 x 0.70mm
NR4050C	NR4050-3	Die Carbon Steel 5 x 0.80mm
NR4060C	NR4060-3	Die Carbon Steel 6 x 1.00mm
NR4080C	NR4080-3	Die Carbon Steel 8 x 1.25mm
NR4100C	NR4100-3	Die Carbon Steel 10 x 1.50mm
NR4120C	NR4120-3	Die Carbon Steel 12 x 1.75mm

Wrenches

Carded	Bulk	Description	Size
NR9001C	NR9001B	Tap Wrench No.0	2.1 - 4.9mm (M1 - M8)
NR9002C	NR9002B	Tap Wrench No.1½	2.4 - 7mm (M1 - M12)
NR9003C	NR9003B	Tap Wrench No.2	3.4 - 8mm (M4 - M12)
NR9004C	NR9004B	Tap Wrench No.3	4.9 - 12mm (M5 - M20)
NR9005C	NR9005B	Tap Wrench No.4	5.5 - 16mm (M9 - M27)
NR9006C	NR9006B	T Tap Wrench	1.6 - 6.3mm
NR9007C	NR9007B	T Tap Wrench	7.9 - 12.7mm
NR9008C	NR9008B	Die Holder 1"	25mm x 9mm
NR9009C		Die Holder 1"	38mm x 14mm
	NR9010B	Die Holder Hex 1½"	M14 - M18
	NR9020B	Die Holder Hex 1⅞"	M20 - M24



Tap & Die Sets

INDUSTRIAL



Part No. T9322
32pce HSS Tap & Die Set
3 - 12mm in Steel Case

INDUSTRIAL



Part No. T9441
44pce HSS Tap & Die Set
3 - 12mm in Metal Case



Part No. T9111
110pce Carbon Steel
Tap & Die Set
2 - 18mm
in blow mould case

CARBON STEEL TAP & DIE SETS (in plastic case)

NR SET12	12 Pce	5 Pce Taps - M3, M4, M5, M6, M8, 5 Pce Dies - M3, M4, M5, M6, M8, 1 Pce Tap Wrench, 1 Pce Die Holder
NR SET16	16 Pce	7pce Taps - M3x0.5, M4x0.7, M5x0.8, M6x1.0, M8x1.25, M10x1.5, M12x1.75 7pce Dies - M3x0.5, M4x0.7, M5x0.8, M6x1.0, M8x1.25, M10x1.5, M12x1.75 1pce Tap Wrench (M3 - M12), 1 pce Die Wrench (25 X 9)
NR SET20	20 Pce	9pce Taps - M3x0.5, M4x0.7, M5x0.8, M6x1.0, M7x1.0, M8x1.25, M9x1.25, M10x1.5, M12x1.75 9pce Dies - M3x0.5, M4x0.7, M5x0.8, M6x1.0, M7x1.0, M8x1.25, M9x1.25, M10x1.5, M12x1.75 1pce Tap Wrench (M3 - M12), 1pce Die Wrench (25 X 9)
NR SET20-2	20 Pce	9pce Taps - 6xNC32, 8xNC32, 10xNC24, 12xNC24, 1/4xNC20, 5/16xNC18, 3/8xNC16, 7/16xNC14, 1/2xNC13 9pce Dies - 6xNC32, 8xNC32, 10xNC24, 12xNC24, 1/4xNC20, 3/8xNC16, 5/16xNC18, 7/16xNC14, 1/2xNC13 1pce Tap Wrench M3 - M12, 1pce Die Wrench 1"
NR SET39	39 Pce	16pce Taps - M3x0.5, M3x0.6, M4x0.7, M4x0.75, M5x0.8, M5x0.9, M6x0.75, M6x1.0, M7x0.75, M7x1.0, M8x1.0, M8x1.25, M10x1.25, M10x1.5, M12x1.5, M12x1.75 16pce Dies - M3x0.5, M3x0.6, M4x0.7, M4x0.75, M5x0.8, M5x0.9, M6x0.75, M6x1.0, M7x0.75, M7x1.0, M8x1.0, M8x1.25, M10x1.25, M10x1.5, M12x1.5, M12x1.75 1pce BSP Tap, 1pce BSP Die, 1pce Tap Wrench M3-M12, 1pce T-Tap Wrench, 1pce Die Wrench 25x9mm, 1pce Screwdriver, 1pce Screw Pitch Gauge



NR SET12
CARBON STEEL



NR SET16
CARBON STEEL



NR SET20
CARBON STEEL



NR SET20-2
CARBON STEEL



NR SET39
CARBON STEEL



TC831601
13 Pce Tap & Die Set
in plastic case

Thread Repair Kits

Part No.	Description
NR5004	29 Pce Thread Repair Kit M4 x 0.7 x 1.5mm
NR5005	29 Pce Thread Repair Kit M5 x 0.8 x 1.5mm
NR5006	29 Pce Thread Repair Kit M6 x 1.0 x 1.5mm
NR5008	29 Pce Thread Repair Kit M8 x 1.25 x 1.5mm
NR5010	14 Pce Thread Repair Kit M10 x 1.5 x 1.5mm
NR5012	14 Pce Thread Repair Kit M12 x 1.75 x 1.5mm
NR5004-01	10 Pce Replacement Inserts M4 x 1D
NR5004-02	10 Pce Replacement Inserts M4 x 1.5D
NR5004-03	10 Pce Replacement Inserts M4 x 2D
NR5005-01	10 Pce Replacement Inserts M5 x 1D
NR5005-02	10 Pce Replacement Inserts M5 x 1.5D
NR5005-03	10 Pce Replacement Inserts M5 x 2D
NR5006-01	10 Pce Replacement Inserts M6 x 1D
NR5006-02	10 Pce Replacement Inserts M6 x 1.5D
NR5006-03	10 Pce Replacement Inserts M6 x 2D
NR5008-01	10 Pce Replacement Inserts M8 x 1D
NR5008-02	10 Pce Replacement Inserts M8 x 1.5D
NR5008-03	10 Pce Replacement Inserts M8 x 2D
NR5010-01	5 Pce Replacement Inserts M10 x 1D
NR5010-02	5 Pce Replacement Inserts M10 x 1.5D
NR5010-03	5 Pce Replacement Inserts M10 x 2D
NR5012-01	5 Pce Replacement Inserts M12 x 1D
NR5012-02	5 Pce Replacement Inserts M12 x 1.5D
NR5012-03	5 Pce Replacement Inserts M12 x 2D



NR5004

NR5006



NR5010



NR5006-01

NR5008-03



Hand Reamers

Part No.	Size
TCHR012	12mm
TCHR019	19mm



Made of hardened & tempered tool steel with precision ground cutting edges. The T-handle provides leverage for easier reaming.



Part No. TC0358BPR

Pipe De-burring Reamer HSS 0 - 35mm



Spot Weld Drill



Part No. DR30060
6 x 40mm
INDUSTRIAL

Part No. DR30080
8 x 40mm
INDUSTRIAL



Drill Adaptor Set

Part No. T AD0345
3 Pce Drill Adaptor Set
Sizes; 3, 4, 5mm Round Grub Screw Type
1/4" Hex Shank

» Convert your standard round shank drill bit into a hex shank for easy interchange

Cutting Oil

Part No. CAN32772
Oil Cutting for Drilling
500ml Aerosol

Part No. CAN32862
Oil Cutting for Drilling
500ml Bottle w/Spout



Screw Extractors

Part No.	Description
TC SE01	Screw Extractor No.1 Carded
TC SE02	Screw Extractor No.2 Carded
TC SE03	Screw Extractor No.3 Carded
TC SE04	Screw Extractor No.4 Carded
TC SE05	Screw Extractor No.5 Carded
TC SE06	Screw Extractor No.6 Carded

Individually packaged, removes broken bolts and studs



Screw Extractor Drill Guide	
Extractor #	Drill Size
#5	9.5mm
#4	6.0mm
#3	5.5mm
#2	4.0mm
#1	3.3mm

Screw Extractor Sets

Part No. TC SE06007
5 Pce Screw Extractor Set
(on skin card)
#1, #2, #3, #4, #5

The most popular extractors packaged in plastic storage case



Part No. TC SE06008

5 Pce Square Screw Extractor Set
#5 use drill 9.5mm
#4 use drill 8.0mm
#3 use drill 6.0mm
#2 use drill 4.8mm
#1 use drill 3.2mm



Part No. TC SE06009

5 Pce Spiral Screw Extractor Set
#5 use drill 9.5mm
#4 use drill 8.0mm
#3 use drill 6.0mm
#2 use drill 4.8mm
#1 use drill 3.2mm



Part No. TC41012

12 Pce Screw Extractor & HSS Drill Set

Contents:

6 x Screw Extractors;
#1, #2, #3, #4, #5, #6
6 x HSS Drills
M2, M3, M4, M5, M7, M10

INDUSTRIAL

Thread Lock

Bearing Lock

Part No.	Size
TCTL010-10	10 grams
TCTL010	50 grams
TCTL010-250	250 grams

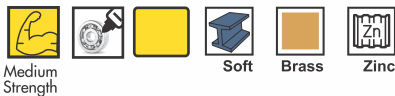

Medium Strength

Soft

Brass

Zinc

Retaining standard size bearings.
Use on brass/zinc/steel

Sleeve Lock

Part No.	Size
TCTL020-10	10 grams
TCTL020	50 grams
TCTL020-250	250 grams

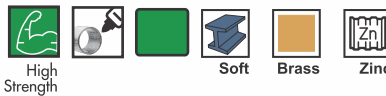

High Strength

Soft

Brass

Zinc

Retaining large size cylindrical parts.
Use on brass/zinc/steel

Screw Lock

Part No.	Size
TCTL030-10	10 grams
TCTL030	50 grams
TCTL030-250	250 grams



Low Strength

Soft

Brass

Zinc

Thread lock for small size threads.
Use on brass/zinc/steel

Nut Lock

Part No.	Size
TCTL040-10	10 grams
TCTL040	50 grams
TCTL040-250	250 grams

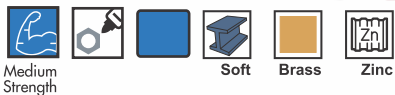

Medium Strength

Soft

Brass

Zinc

Thread lock for standard size threads.
Use on brass/zinc/steel

Stud Lock

Part No.	Size
TCTL050-10	10 grams
TCTL050	50 grams
TCTL050-250	250 grams



High Strength

Soft

Brass

Zinc

Thread lock for standard size threads.
Use on brass/zinc/steel

Bolt Lock

Part No.	Size
TCTL060-10	10 grams
TCTL060	50 grams
TCTL060-250	250 grams

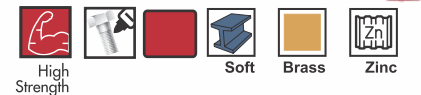

High Strength

Soft

Brass

Zinc

Thread lock for large size threads.
Use on brass/zinc/steel



HSS Standard Drill Bits



Part No.	Description	Card	Part No.	Description	Card	Part No.	Description	Card
DR10010	HSS 1.0mm	2/Card	DR10038	HSS 3.8mm	1/Card	DR10078	HSS 7.8mm	1/Card
DR10015	HSS 1.5mm	2/Card	DR10040	HSS 4.0mm	1/Card	DR10080	HSS 8.0mm	1/Card
DR10016	HSS 1.6mm	2/Card	DR10042	HSS 4.2mm	1/Card	DR10082	HSS 8.2mm	1/Card
DR10018	HSS 1.8mm	2/Card	DR10045	HSS 4.5mm	1/Card	DR10085	HSS 8.5mm	1/Card
DR10020	HSS 2.0mm	2/Card	DR10048	HSS 4.8mm	1/Card	DR10090	HSS 9.0mm	1/Card
DR10022	HSS 2.2mm	2/Card	DR10050	HSS 5.0mm	1/Card	DR10095	HSS 9.5mm	1/Card
DR10025	HSS 2.5mm	2/Card	DR10052	HSS 5.2mm	1/Card	DR10100	HSS 10.0mm	1/Card
DR10028	HSS 1.8mm	2/Card	DR10055	HSS 5.5mm	1/Card	DR10102	HSS 10.2mm	1/Card
DR10029	HSS 2.9mm	2/Card	DR10060	HSS 6.0mm	1/Card	DR10105	HSS 10.5mm	1/Card
DR10030	HSS 3.0mm	2/Card	DR10062	HSS 6.2mm	1/Card	DR10110	HSS 11.0mm	1/Card
DR10032	HSS 3.2mm	2/Card	DR10065	HSS 6.5mm	1/Card	DR10115	HSS 11.5mm	1/Card
DR10033	HSS 3.3mm	2/Card	DR10068	HSS 6.8mm	1/Card	DR10120	HSS 12.0mm	1/Card
DR10035	HSS 3.5mm	1/Card	DR10070	HSS 7.0mm	1/Card	DR10125	HSS 12.5mm	1/Card
DR10037	HSS 3.7mm	1/Card	DR10075	HSS 7.5mm	1/Card	DR10130	HSS 13.0mm	1/Card



Wood Drill Bits



Part No.	Description	1/Card
DR09003	Wood 3.0mm x 60mm	
DR09004	Wood 4.0mm x 75mm	
DR09005	Wood 5.0mm x 85mm	
DR09006	Wood 6.0mm x 95mm	
DR09008	Wood 8.0mm x 115mm	
DR09010	Wood 10mm x 133mm	
DR09012	Wood 12mm x 150mm	



HSS Standard Drill Bits



Part No.	Description	Pack	Part No.	Description	Pack
DR60020	HSS 2.0mm	10/Pack	DR60060	HSS 6.0mm	10/Pack
DR60025	HSS 2.5mm	10/Pack	DR60065	HSS 6.5mm	10/Pack
DR60030	HSS 3.0mm	10/Pack	DR60070	HSS 7.0mm	10/Pack
DR60032	HSS 3.2mm	10/Pack	DR60080	HSS 8.0mm	10/Pack
DR60035	HSS 3.5mm	10/Pack	DR60082	HSS 8.2mm	10/Pack
DR60038	HSS 3.8mm	10/Pack	DR60090	HSS 9.0mm	10/Pack
DR60040	HSS 4.0mm	10/Pack	DR60100	HSS 10.0mm	5/Pack
DR60042	HSS 4.2mm	10/Pack	DR60105	HSS 10.5mm	5/Pack
DR60045	HSS 4.5mm	10/Pack	DR60110	HSS 11.0mm	5/Pack
DR60048	HSS 4.8mm	10/Pack	DR60115	HSS 11.5mm	5/Pack
DR60050	HSS 5.0mm	10/Pack	DR60120	HSS 12.0mm	5/Pack
DR60055	HSS 5.5mm	10/Pack	DR60125	HSS 12.5mm	5/Pack
			DR60130	HSS 13.0mm	5/Pack



HSS Industrial Drill Bits



1/Card	2/Card	10/Pack	Description	1/Card	5/Pack	10/Pack	Description
		DR20010	1.0mm 135°	DR20060		DR22060	6.0mm 135°
		DR20015	1.5mm 135°	DR20065		DR22065	6.5mm 135°
		DR20020	2.0mm 135°	DR20070		DR22070	7.0mm 135°
		DR20025	2.5mm 135°	DR20075		DR22075	7.5mm 135°
		DR20028	2.8mm 135°	DR20080		DR22080	8.0mm 135°
		DR20030	3.0mm 135°	DR20085		DR22085	8.5mm 135°
		DR20032	3.2mm 135°	DR20090		DR22090	9.0mm 135°
		DR20033	3.3mm 135°	DR20095		DR22095	9.5mm 135°
DR20035		DR22035	3.5mm 135°	DR20100	DR22100		10.0mm 135°
DR20038		DR22038	3.8mm 135°	DR20105	DR22105		10.5mm 135°
DR20040		DR22040	4.0mm 135°	DR20110	DR22110		11.0mm 135°
DR20042		DR22042	4.2mm 135°	DR20115	DR22115		11.5mm 135°
DR20045		DR22045	4.5mm 135°	DR20120	DR22120		12.0mm 135°
DR20048		DR22048	4.8mm 135°	DR20125	DR22125		12.5mm 135°
DR20050		DR22050	5.0mm 135°	DR20130	DR22130		13.0mm 135°
DR20055		DR22055	5.5mm 135°				

INDUSTRIAL



HSS Turbo Point Drill Bits



Part No.	Description	Card	Part No.	Description	Card	Part No.	Description	Card
DR40020	2.0mm	1/Card	DR40050	5.0mm	1/Card	DR40095	9.5mm	1/Card
DR40025	2.5mm	1/Card	DR40055	5.5mm	1/Card	DR40100	10.0mm	1/Card
DR40030	3.0mm	1/Card	DR40060	6.0mm	1/Card	DR40105	10.5mm	1/Card
DR40032	3.2mm	1/Card	DR40065	6.5mm	1/Card	DR40110	11.0mm	1/Card
DR40035	3.5mm	1/Card	DR40070	7.0mm	1/Card	DR40115	11.5mm	1/Card
DR40040	4.0mm	1/Card	DR40075	7.5mm	1/Card	DR40120	12.0mm	1/Card
DR40042	4.2mm	1/Card	DR40080	8.0mm	1/Card	DR40125	12.5mm	1/Card
DR40045	4.5mm	1/Card	DR40085	8.5mm	1/Card	DR40130	13.0mm	1/Card
DR40048	4.8mm	1/Card	DR40090	9.0mm	1/Card			

INDUSTRIAL



Turbo Pointed Drill Bit advantages » remains sharper for longer
» precise drilling

Morse Taper Shank Drill Bits



Plastic



Hard & Softwood



Mild Steel

Part No.	Description	Part No.	Description	Part No.	Description
DR50100	HSS 10mm x MT1	DR50165	HSS 16.5mm x MT2	DR50225	HSS 22.5mm x MT2
DR50105	HSS 10.5mm x MT1	DR50170	HSS 17mm x MT2	DR50230	HSS 23mm x MT2
DR50110	HSS 11mm x MT1	DR50175	HSS 17.5mm x MT2	DR50240	HSS 24mm x MT3
DR50120	HSS 12mm x MT1	DR50180	HSS 18mm x MT2	DR50250	HSS 25mm x MT3
DR50125	HSS 12.5mm x MT1	DR50185	HSS 18.5mm x MT2	DR50260	HSS 26mm x MT3
DR50130	HSS 13mm x MT1	DR50190	HSS 19mm x MT2	DR50270	HSS 27mm x MT3
DR50135	HSS 13.5mm x MT1	DR50195	HSS 19.5mm x MT2	DR50280	HSS 28mm x MT3
DR50140	HSS 14mm x MT1	DR50200	HSS 20mm x MT2	DR50290	HSS 29mm x MT3
DR50145	HSS 14.5mm x MT2	DR50205	HSS 20.5mm x MT2	DR50300	HSS 30mm x MT3
DR50150	HSS 15mm x MT2	DR50210	HSS 21mm x MT2	DR50310	HSS 31mm x MT3
DR50155	HSS 15.5mm x MT2	DR50215	HSS 21.5mm x MT2	DR50320	HSS 32mm x MT4
DR50160	HSS 16mm x MT2	DR50220	HSS 22mm x MT2	DR50350	HSS 35mm x MT4

INDUSTRIAL



Stubby End Double End Drill Bits



Plastic



Hard & Softwood



Mild Steel

Part No.	Pk Size	Part No.	Pk Size	Description	Part No.	Pk Size	Part No.	Pk Size	Description
DR55030	10 Pk	DR55030-1	1 Pk	HSS 3mm	DR55045	10 Pk	DR55045-1	1 Pk	HSS 4.5mm
DR55032	10 Pk	DR55032-1	1 Pk	HSS 3.2mm	DR55048	10 Pk	DR55048-1	1 Pk	HSS 4.8mm
DR55033	10 Pk	DR55033-1	1 Pk	HSS 3.3mm	DR55049	10 Pk	DR55049-1	1 Pk	HSS 4.9mm
DR55035	10 Pk	DR55035-1	1 Pk	HSS 3.5mm	DR55050	10 Pk	DR55050-1	1 Pk	HSS 5mm
DR55038	10 Pk	DR55038-1	1 Pk	HSS 3.8mm	DR55052	10 Pk	DR55052-1	1 Pk	HSS 5.2mm
DR55040	10 Pk	DR55040-1	1 Pk	HSS 4mm	DR55055	10 Pk	DR55055-1	1 Pk	HSS 5.5mm
DR55042	10 Pk	DR55042-1	1 Pk	HSS 4.2mm	DR55060	10 Pk	DR55060-1	1 Pk	HSS 6mm

INDUSTRIAL



Masonry/Concrete Drill Bits



Brick



Concrete

Part No.	Description	Card	Part No.	Description	Card	Part No.	Description	Card
DR80030	3.0mm	1/Card	DR80090	9.0mm	1/Card	DR80180	18.0mm	1/Card
DR80040	4.0mm	1/Card	DR80100	10.0mm	1/Card	DR80200	20.0mm	1/Card
DR80050	5.0mm	1/Card	DR80110	11.0mm	1/Card	DR83080	8 x 400mm	1/Card
DR80055	5.5mm	1/Card	DR80120	12.0mm	1/Card	DR83100	10 x 400mm	1/Card
DR80060	6.0mm	1/Card	DR80130	13.0mm	1/Card	DR83120	12 x 400mm	1/Card
DR80065	6.5mm	1/Card	DR80140	14.0mm	1/Card	DR83160	16 x 400mm	1/Card
DR80070	7.0mm	1/Card	DR80160	16.0mm	1/Card	DR83200	20 x 400mm	1/Card
DR80080	8.0mm	1/Card						

INDUSTRIAL



SDS Plus Drill Bits



Brick



Concrete

Part No.	Description	Part No.	Description	Part No.	Description	Part No.	Description
DR70040	110 x 50 4mm	DR71050	160 x 100 5mm	DR71200	160 x 100 12mm	DR72100	210 x 150 10mm
DR70050	110 x 50 5mm	DR71055	160 x 100 5.5mm	DR71300	160 x 100 13mm	DR72120	210 x 150 12mm
DR70055	110 x 50 5.5mm	DR71060	160 x 100 6mm	DR71400	160 x 100 14mm	DR72140	210 x 150 14mm
DR70060	110 x 50 6mm	DR71065	160 x 100 6.5mm	DR71600	160 x 100 16mm	DR72160	210 x 150 16mm
DR70080	110 x 50 8mm	DR71070	160 x 100 7mm	DR72060	210 x 150 6mm	DR72180	210 x 150 18mm
DR70100	110 x 50 10mm	DR71080	160 x 100 8mm	DR72080	210 x 150 8mm	DR72200	210 x 150 20mm
		DR71100	160 x 100 10mm				

INDUSTRIAL



SDS Plus Drill Bits



Brick



Concrete

Part No.	Description	Part No.	Description	Part No.	Description
DR73060	SDS Plus 260 x 200mm 6mm	DR74060	SDS Plus 310 x 250mm 6mm	DR75080	SDS Plus 400 x 310 8mm
DR73080	SDS Plus 260 x 200mm 8mm	DR74080	SDS Plus 310 x 250mm 8mm	DR75010	SDS Plus 400 x 310 10mm
DR73100	SDS Plus 260 x 200mm 10mm	DR74100	SDS Plus 310 x 250mm 10mm	DR75120	SDS Plus 400 x 310 12mm
DR73120	SDS Plus 260 x 200mm 12mm	DR74120	SDS Plus 310 x 250mm 12mm	DR75140	SDS Plus 400 x 310 14mm
DR73140	SDS Plus 260 x 200mm 14mm	DR74140	SDS Plus 310 x 250mm 14mm	DR75160	SDS Plus 400 x 310 16mm
DR73160	SDS Plus 260 x 200mm 16mm	DR74160	SDS Plus 310 x 250mm 16mm	DR75180	SDS Plus 400 x 310 18mm
DR73180	SDS Plus 260 x 200mm 18mm	DR74180	SDS Plus 310 x 250mm 18mm	DR75200	SDS Plus 400 x 310 20mm
DR73200	SDS Plus 260 x 200mm 20mm	DR74200	SDS Plus 310 x 250mm 20mm	DR75220	SDS Plus 400 x 310 22mm
DR73220	SDS Plus 260 x 200mm 22mm	DR74220	SDS Plus 310 x 250mm 22mm	DR75240	SDS Plus 400 x 310 24mm
DR73240	SDS plus 260 x 200mm 24mm	DR74250	SDS Plus 310 x 250mm 25mm	DR75250	SDS Plus 400 x 310 25mm
DR73250	SDS Plus 260 x 200mm 25mm				

INDUSTRIAL



SDS Max Cross Head Drill Bit

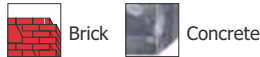

Part No.	Description
MX32020	SDS Max Double Flute 320 x 200 x 20
MX34012	SDS Max Double Flute 340 x 200 x 12
MX34014	SDS Max Double Flute 340 x 200 x 14
MX34016	SDS Max Double Flute 340 x 200 x 16
MX52020	SDS Max Double Flute 520 x 400 x 20
MX52022	SDS Max Double Flute 520 x 400 x 22
MX52025	SDS Max Double Flute 520 x 400 x 25
MX54016	SDS Max Double Flute 540 x 400 x 16
MX54018	SDS Max Double Flute 540 x 400 x 18
MX54032	SDS Max Double Flute 540 x 400 x 32
MX57032	SDS Max Double Flute 570 x 450 x 32
MX57038	SDS Max Double Flute 570 x 450 x 38

INDUSTRIAL



Drill Bit Measuring Plate

Part No.	Description
TCDS001	Drill Bit Measuring Plate Single layer 1 - 13mm

Used to accurately measure diameters of drill bits



Chisels

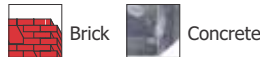

Part No.	Description
TCCH25000-1	SDS Plus Pointed 14 x 250mm
TCCH25020-1	SDS Plus Flat 20 x 250mm
TCCH25022-1	SDS Plus Gouge 14 x 250 x 22mm
TCCH25040-1	SDS Plus Flat 14 x 250 x 40mm
TCCH28000	SDS Max Pointed 280mm
TCCH28030	SDS Max Flat 280 x 30mm
TCCH28040	SDS Max Flat 280 x 40mm
TCCH28075	SDS Max Flat 280 x 75mm
TCCH40000	SDS Max Pointed 400mm
TCCH40000-2	SDS Plus Pointed 400mm
TCCH40030	SDS Max Flat 400 x 30mm
TCCH40030-2	SDS Flat 30 x 400mm
TCCH40040	SDS Max Flat 400 x 40mm
TCCH40040-2	SDS Flat 40 x 400mm
TCCH40075	SDS Max Flat 400 x 75mm



Drill Stop

Part No.	Description
TCDS002	7 Pce Drill Stop Set 5, 6, 8, 10, 11, 12mm c/with Allen Key



Application
» For accurate depth hole drilling



SDS Plus Drill & Chisel Sets

Part No.	Description
TCYC01001	10 Pce - Drill; 5, 6 & 8 x 110mm, 10, 12 x 160mm, 14, 16 x 210mm, 20 x 400mm Chisels; Pointed 14 x 250mm, Flat 14 x 250mm
TCYC01201	12 Pce - Drill; 5, 6 x 110mm, 8, 10, 12 x 160mm, 14, 16 x 210mm, 18 x 310mm, 20 x 450mm Chisels; Pointed 14 x 250mm, Flat 14 x 250 x 20mm, Groove 14 x 250 x 22mm
TCYC01401	3 Pce - SDS Plus Chisel Set - Pointed 14mm, Flat 20mm & 40mm Blister packed
TCYC1501	3 Pce - SDS Max Chisel Set - Pointed 18mm, Flat 25mm & 40mm, Blister packed

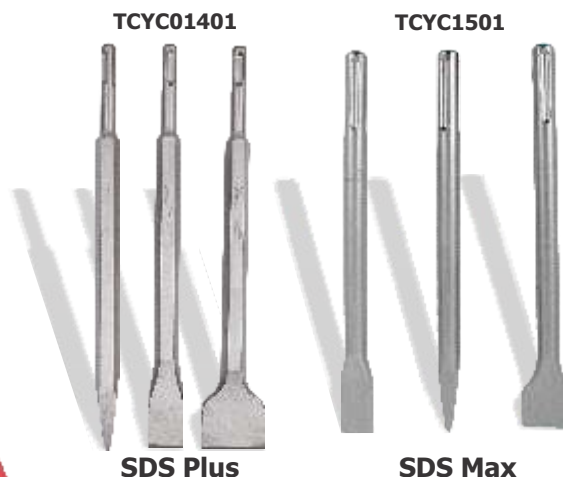

Drill Bit Sets HSS

ROLL FORGED

Part No.	Size / Description
NR00013	13pce in Metal Case
NR00019	19pce in Metal Case
NR00025	25pce in Metal Case

Application/Material

For drilling mild steels, carbon steels, alloy steels, wood, composition board plastic and PVC

Features/Benefits

- Packaged in a sturdy metal index case



NR00013 NR00019 NR00025



TITANIUM COATED

Part No.	Size / Description
NR02013	13pce in Metal Case
NR02019	19pce in Metal Case
NR02025	25pce in Metal Case

Features/Benefits

- Tork Craft have chosen a top quality, fully ground HSS drill bit sharpened with a split point which prevents drill walking
- Titanium coated - lasts up to 6x longer than standard HSS bits
- Packaged in a sturdy metal index case



NR02013 NR02019 NR02025



FULLY GROUND - Bright Finish

Part No.	Size / Description
NR01013	13pce in Metal Case
NR01019	19pce in Metal Case
NR01025	25pce in Metal Case

Application/Material

For drilling mild steels, carbon steels, alloy steels, wood, composition board plastic and PVC. For industrial users and precision drilling

Features/Benefits

- Packaged in a sturdy metal index case



NR01013 NR01019 NR01025



COBALT - Bright Finish

Part No.	Size / Description
NR03019	19pce in Metal Case
NR03025	25pce in Metal Case

Application/Material

For drilling high strength steels and stainless steel.

For professional and industrial users.

Features/Benefits

- Packaged in a sturdy metal index case



NR03019 NR03025



TURBO POINT

Part No.	Size / Description
NR04013	13pce in Metal Case
NR04019	19pce in Metal Case
NR04025	25pce in Metal Case

Application/Material

Special tip for aggressive cutting in metals For professional and industrial users.

Features/Benefits

- Packaged in a sturdy metal index case



NR04013 NR04019 NR04025

Part No. Size / Description

NR07105	5pce Wood Set 4, 5, 6, 8, 10mm in Plastic Case
NR07205	5pce HSS Set 4, 5, 6, 8, 10mm in Plastic Case
NR07310	5pce SDS Set 160mm 2 x 6mm, 2 x 8mm, 1 x 10mm in Plastic Case



NR07105
Wood



NR07305
SDS



NR07310 SDS

PRO SERIES Spade Bits



Hard & Softwood

Features of the New Pro Series Spade Bit from Tork Craft

Angle edge design cuts faster than standard bits.

Cutting spurs give cleaner cuts even through knotted timber.

1/4" hex shank for electric and cordless drills.

Available in all the popular sizes

6 - 40mm x 150mm and 6 - 25mm x 400mm.

INDUSTRIAL

Part No.	Description
TCSB006	Spade Bit Pro Series 6 x 150mm
TCSB008	Spade Bit Pro Series 8 x 150mm
TCSB010	Spade Bit Pro Series 10 x 150mm
TCSB012	Spade Bit Pro Series 12 x 150mm
TCSB013	Spade Bit Pro Series 13 x 150mm
TCSB014	Spade Bit Pro Series 14 x 150mm
TCSB016	Spade Bit Pro Series 16 x 150mm
TCSB017	Spade Bit Pro Series 17 x 150mm
TCSB018	Spade Bit Pro Series 18 x 150mm
TCSB019	Spade Bit Pro Series 19 x 150mm
TCSB020	Spade Bit Pro Series 20 x 150mm
TCSB022	Spade Bit Pro Series 22 x 150mm
TCSB024	Spade Bit Pro Series 24 x 150mm
TCSB025	Spade Bit Pro Series 25 x 150mm
TCSB028	Spade Bit Pro Series 28 x 150mm
TCSB030	Spade Bit Pro Series 30 x 150mm
TCSB032	Spade Bit Pro Series 32 x 150mm
TCSB035	Spade Bit Pro Series 35 x 150mm
TCSB038	Spade Bit Pro Series 38 x 150mm
TCSB040	Spade Bit Pro Series 40 x 150mm
TCSB406	Spade Bit Pro Series 6 x 400mm
TCSB408	Spade Bit Pro Series 8 x 400mm
TCSB410	Spade Bit Pro Series 10 x 400mm
TCSB412	Spade Bit Pro Series 12 x 400mm
TCSB413	Spade Bit Pro Series 13 x 400mm
TCSB414	Spade Bit Pro Series 14 x 400mm
TCSB416	Spade Bit Pro Series 16 x 400mm
TCSB418	Spade Bit Pro Series 18 x 400mm
TCSB419	Spade Bit Pro Series 19 x 400mm
TCSB420	Spade Bit Pro Series 20 x 400mm
TCSB422	Spade Bit Pro Series 22 x 400mm
TCSB425	Spade Bit Pro Series 25 x 400mm



PRO SERIES

Wood Spade Bit



Spade Bits



Hard & Softwood

Part No.	Size
TC02075	6mm
TC02076	8mm
TC02077	10mm
TC02078	12mm
TC02079	13mm
TC02080	14mm
TC02081	16mm
TC02082	18mm
TC02083	19mm
TC02084	20mm
TC02085	22mm
TC02087	25mm

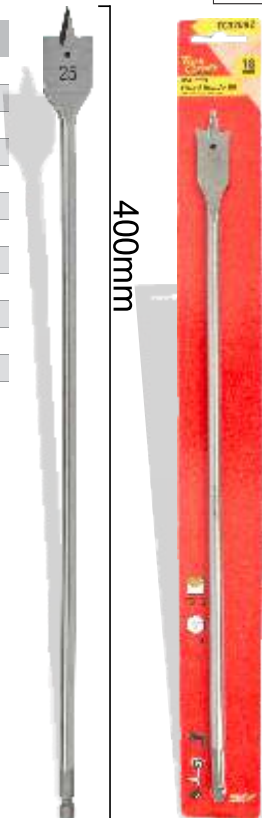

1/4" Hex shank fits all drills & screwdrivers

Part No.	Size
TC02034	6mm
TC02035	8mm
TC02036	10mm
TC02037	12mm
TC02038	13mm
TC02039	14mm
TC02040	16mm
TC020401	17mm
TC02041	18mm
TC02042	19mm
TC02043	20mm
TC02044	22mm
TC02045	24mm
TC02046	25mm
TC02047	28mm
TC02048	30mm
TC02049	32mm
TC02051	35mm
TC02052	38mm
TC02053	40mm



Part No. TC02123
150mm Extension for Spade Bits
Part No. TC02126
300mm Extension for Spade Bits

TORK CRAFT™ 4 Flute Wood Drill Bits



Part No.	Size	Length
BKP010	10mm	150mm
BKP012	12mm	150mm
BKP013	13mm	150mm
BKP014	14mm	150mm
BKP016	16mm	150mm
BKP018	18mm	150mm
BKP019	19mm	150mm
BKP020	20mm	150mm
BKP022	22mm	150mm
BKP024	24mm	150mm
BKP025	25mm	150mm
BKP40010	10mm	400mm
BKP40012	12mm	400mm
BKP40014	14mm	400mm
BKP40016	16mm	400mm
BKP40019	19mm	400mm

INDUSTRIAL



4 Flute
Wood Drill
6x FASTER

6x FASTER
THAN STANDARD SPADE BITS

4 Flute Wood Drill Bits

- 6x faster than standard spade bits
- Designed for faster chip ejection
- Cutting spur for smoother clean holes
- Minimal break out with through holes
- Screw tip for effortless feed
- For use on all types of wood
- 4 blades = faster drilling
- Designed for professionals

TORK CRAFT™ Spade Bits

Top quality TORK CRAFT™ Spade Bits are available in all the popular sizes and are designed to meet the needs of the DIYer as well as the professional user!!



6 Pce 150mm Spade Bit Set
Contents: 10, 12, 16, 19, 20 & 25mm
Part No. TC02116



6 Pce Pro Series Spade Bit Set CARDED
Contents: 10, 12, 16, 18, 20, 25mm
Part No. TCSBS06



Part No. TC02118
13 Pce Spade Bit Set

Titanium MAD-Bit



The MAD Bit is good for use in all types of solid woods, laminates, chipboards, particle board and super wood, etc.

The MAD-bit replaces Augers, Spade bits & Brad bits to form holes in thick timbers and laminates such as joists, noggins, floor boards, decking, kitchen worktops, cupboards & shelves. Typically used when installing plumbing, heating, air-con systems, shower heads & taps, electrical installations like satellite TV, security alarms, mains electric conduits, junction boxes, light switches etc. The MAD-bit is neater and faster than chisels to form mortices and channels in wood and laminates such as door posts, doors, cabinets, chairs and tables, skirting panels, as well as stud walls & partitions. Typically used when installing locks, hinges, rebates & mortice joinery joints.

Part No.	Diameter	Length
MAD10	10mm	130mm
MAD12	12mm	130mm
MAD15	15mm	130mm
MAD16	16mm	130mm
MAD17	17mm	130mm
MAD18	18mm	130mm
MAD19	19mm	130mm
MAD20	20mm	130mm
MAD22	22mm	130mm
MAD25	25mm	130mm
MAD28	28mm	130mm
MAD32	32mm	130mm
MAD35	35mm	130mm



9 different cutting edges
Allows you to cut
Forward
Backwards
Sideways
Straight
Curved

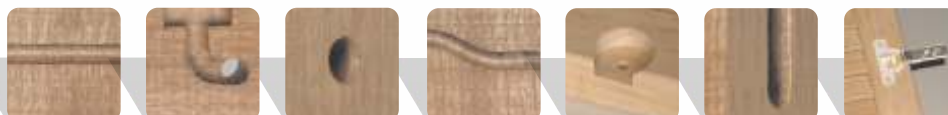

Cuts Mills Drills Channels Flat-bottomed Holes Routes Edge Drilling

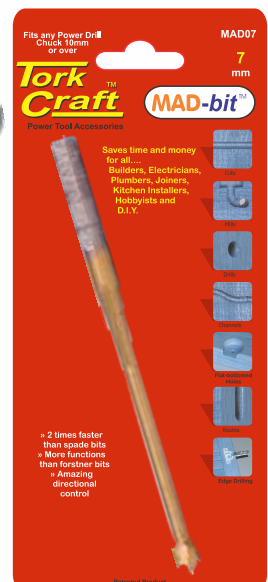

Drill Bit Sets

Part No.	Description
NRM00005	5 Pce Masonry Drill Bit Set 4 - 10mm
NR05005-1	5 Pce Drill Bit Set Half Ground Polished Hex Shank 1.5 - 5mm
NR05005-2	5 Pce Drill Bit Set Fully Ground Titanium Hex Shank 1.5 - 5mm
NR00006	6 Pce HSS Roll Forged Drill Bit Set 2 - 8mm
NR01006	6 Pce HSS Fully Ground Drill Bit Set 2 - 8mm
NRM00008	8 Pce Masonry Drill Bit Set 3 - 9mm
NRM00016	16 Pce Masonry Drill Bit Set 3 - 16mm
NR00015	15 Pce Drill Bit Set HSS TIN & 13mm Chuck & Key Set
NR06070	70 Pce Drill & Accessories set

STANDARD



NR00006 NRM00005 NR01006



NR05005-1



NR05005-2



NRM00008



NRM00016



TZ MG H0705

7pce 1/4" Drive
Quick Change Drill Kit

Contents:

- AC33B 1/4" Quick Change Connector
- 6 HSS Drill Bits



NR06070

70 Piece Combo Drill & Accessories Set

- 5 x HSS Drill Bits
- 5 x Wood Drill Bits
- 5 x Masonry Drill Bits
- 45 x Wall Plugs
- 1 x Carbon Steel Countersink
- 1 x Magnetic Holder
- 8 x 25mm Insert Bits

NR06015 : 3 Set Combo
WOOD - 4, 5, 6, 8 & 10mm
HSS Polished/Half Ground
 4, 5, 6, 8 & 10mm
MASONRY Chromed
 4, 5, 6, 8 & 10mm



**TZ AC27
HSS Drill Bits**

Die Casting
Hex Shank allows
more torque
and lasts longer.

Drill sizes:
2.5, 3, 4 & 5mm
On blister card



NR08015

15 Piece
Combo Set
WOOD
3, 4, 5, 6, 8mm
HSS
3, 4, 5, 6, 8mm
MASONRY
3, 4, 5, 6, 8mm

NR06018
18 Piece
Combo Set
WOOD
3, 4, 5, 6, 8 & 10mm
HSS
3, 4, 5, 6, 8 & 10mm
MASONRY
3, 4, 5, 6, 8 & 10mm



Forstner Bits



Hard & Softwood

Part No.	Description	Size
TCFB10	Forstner Bit Blister	10mm
TCFB12	Forstner Bit Blister	12mm
TCFB15	Forstner Bit Blister	15mm
TCFB16	Forstner Bit Blister	16mm
TCFB19	Forstner Bit Blister	19mm
TCFB20	Forstner Bit Blister	20mm
TCFB22	Forstner Bit Blister	22mm
TCFB25	Forstner Bit Blister	25mm
TCFB30	Forstner Bit Blister	30mm
TCFB35	Forstner Bit Blister	35mm
TCFB38	Forstner Bit Blister	38mm
TCFB40	Forstner Bit Blister	40mm
TCFB45	Forstner Bit Blister	45mm
TCFB50	Forstner Bit Blister	50mm
TCFB54	Forstner Bit Blister	54mm

- Bores perfectly smooth, flat-bottomed holes
- Bores accurate holes from any angle
- Carbon steel for longer life
- Ideal for drilling decorative holes used in fine woodworking



Hinge Bore Bit



Hard & Softwood

Hinge Bore Bit - 35mm

Cuts perfect "blind holes" for installing hinges

PART NO. TCHB35T - Titanium Coated

PART NO. TCHB35-2 - Tungsten Tipped

Tungsten tipped = Long life for heavy duty users



Auger Bits



Hard & Softwood

Part No.	Description	Part No.	Description
AB03170	3 x 170mm Pouched	AB14170	14 x 170mm Pouched
AB03300	3 x 300mm Pouched	AB14300	14 x 300mm Pouched
AB03400	3 x 400mm Pouched	AB14400	14 x 400mm Pouched
AB04170	4 x 170mm Pouched	AB14460	14 x 460mm Pouched
AB04300	4 x 300mm Pouched	AB16170	16 x 170mm Pouched
AB04400	4 x 400mm Pouched	AB16300	16 x 300mm Pouched
AB05170	5 x 170mm Pouched	AB16460	16 x 460mm Pouched
AB05300	5 x 300mm Pouched	AB18170	18 x 170mm Pouched
AB05400	5 x 400mm Pouched	AB18300	18 x 300mm Pouched
AB06170	6 x 170mm Pouched	AB18460	18 x 460mm Pouched
AB06300	6 x 300mm Pouched	AB19170	19 x 170mm Pouched
AB06400	6 x 400mm Pouched	AB19300	19 x 300mm Pouched
AB06460	6 x 460mm Pouched	AB19300B	19 x 300mm Bulk
AB08170	8 x 170mm Pouched	AB19460	19 x 460mm Pouched
AB08300	8 x 300mm Pouched	AB20170	20 x 170mm Pouched
AB08400	8 x 400mm Pouched	AB20300	20 x 300mm Pouched
AB08460	8 x 460mm Pouched	AB20460	20 x 460mm Pouched
AB10170	10 x 170mm Pouched	AB22170	22 x 170mm Pouched
AB10300	10 x 300mm Pouched	AB22300	22 x 300mm Pouched
AB10400	10 x 400mm Pouched	AB22300B	22 x 300mm Bulk
AB10460	10 x 460mm Pouched	AB22460	22 x 460mm Pouched
AB12170	12 x 170mm Pouched	AB24170	24 x 170mm Pouched
AB12300	12 x 300mm Pouched	AB24300	24 x 300mm Pouched
AB12400	12 x 400mm Pouched	AB24460	24 x 460mm Pouched
AB12460	12 x 460mm Pouched	AB25170	25 x 170mm Pouched
AB13170	13 x 170mm Pouched	AB25300	25 x 300mm Pouched
AB13300	13 x 300mm Pouched	AB25460	25 x 460mm Pouched
AB13400	13 x 400mm Pouched	TCAB22300SP	22 x 300mm (10mm Shaft Bulk)
AB13460	13 x 460mm Pouched		

For drilling in all soft and hard woods
Screw tip design provides faster drilling action

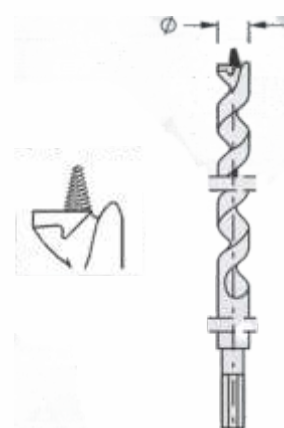

Scotch Eye Auger Bit



Hard & Softwood

Part No.	Size
TCSA40008	8mm x 400mm
TCSA40010	10mm x 400mm
TCSA40012	12mm x 400mm
TCSA40013	13mm x 400mm
TCSA40014	14mm x 400mm
TCSA40016	16mm x 400mm
TCSA40019	19mm x 400mm
TCSA40020	20mm x 400mm
TCSA40022	22mm x 400mm
TCSA40025	25mm x 400mm

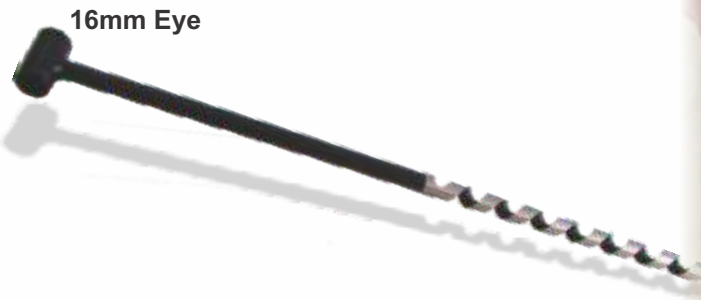

16mm Eye



- For hand operation.
- An auger handle / T bar is placed through the eye and the auger is turned by hand to bore.
- Boring a wide range of holes in hardwoods in a variety of locations especially where electrical power is not available.

Expansive Bit



Hard & Softwood

Part No.	Description
TC312001	Expansive Bit 15-45mm For Wood
TC312004	Expansive Bit 22-76mm For Wood



- » Use one drill for many sizes
- » Easily adjusts to any size between 15-76mm
- » Screw point to centre and pull drill through timber

Plug Cutters



Hard & Softwood

Part No.	Size
TC11001	6mm
TC11002	8mm
TC11004	10mm
TC11007	12mm
TC11009	13mm
TC11012	14mm
TC11015	16mm
TC11016	20mm
TC11018	25mm

- Bit produces accurate plugs from any type of wood
- Use to fill counter-bored holes
- Hardened-steel body for long life
- Precision-ground cutters for fine woodworking
- 1/4" shank fits any drill
- Use an offcut to match timber perfectly



5 Piece Plug Cutter Set
 Sizes: 6, 8, 10, 12, 16mm
 PART NO. TC311024

Plug, Dowel & Tenon Cutters



Hard & Softwood

Part No.	Size
W60008	8mm
W60010	10mm
W60012	12mm
W60016	16mm
W60020	20mm
W60022	22mm
W60025	25mm

INDUSTRIAL



Overall Length: 140mm
Max. Length of plug: 70mm
 » Packaged in hanging tube

Precise ground inner and outer cutting edges cut through the hardest woods maintaining an extremely sharp edge. Suitable for large quantities and highly accurate.

NB. For use only in a drill press and the work piece must be clamped.





TORK CRAFT™ Diamond Core Tile Bits



Glass



Tiles



Porcelain

Watch our video link <http://www.youtube.com/watch?v=vxavnokjtzo>

USAGE INSTRUCTIONS

The drill must be used with water cooling at all times (maximum permissible temperature of diamond tip 500°C). Drilling with water can be done using the following methods;

Tile attached to wall:

- Spraying water onto the surface
- Using a wet sponge
- Attaching a water feed device to allow a constant stream of water to run down the tile and into the target hole.

Loose tile or horizontal surface:

Pour water onto the tile and create a small puddle over the intended position of the hole, drill "through" the water and the spiral feed will draw water to the cutting edge as the hole is drilled. After drilling each hole, allow the tool to cool down completely and clean it before proceeding. The tool life will depend on correct usage and tile hardness. 10 or more holes are possible in hard tiles. We are unable to offer any guarantee if the tool is used dry.

Start Drilling;

- Use lengths of double-sided adhesive tape to secure the drilling template.
- Select the correct spindle speed:

Drill diameter	5	6	7/8	10	>12
Spindle speed	800	600	500	400	<300
- Apply only low feed pressure (grinding process).
- To start the hole you must have the drill rotating prior to touching the surface of the tile.
- Start drilling at a 45° angle to avoid skating on the tile.
- Once a groove has been made slowly raise the drill bit up to a horizontal or vertical level then continue drilling.
- The Tork Craft Diamond Tile Drill will work with all power units.
- Select a slower speed if water source is restricted.

Part No.	Size	Description
TC180803	3mm	Diamond Core Bit
TC180804	4mm	Diamond Core Bit
TC180805	5mm	Diamond Core Bit
TC180806	6mm	Diamond Core Bit
TC180808	8mm	Diamond Core Bit
TC180810	10mm	Diamond Core Bit
TC180812	12mm	Diamond Core Bit
TC180814	14mm	Diamond Core Bit
TC180815	15mm	Diamond Core Bit
TC180816	16mm	Diamond Core Bit
TC180819	19mm	Diamond Core Bit
TC180820	20mm	Diamond Core Bit
TC180822	22mm	Diamond Core Bit
TC180825	25mm	Diamond Core Bit
TC180830	30mm	Diamond Core Bit
TC180832	32mm	Diamond Core Bit
TC180835	35mm	Diamond Core Bit
TC180838	38mm	Diamond Core Bit

Part No.	Size	Description
TC180840	40mm	Diamond Core Bit
TC180850	50mm	Diamond Core Bit
TC180857	57mm	Diamond Core Bit
TC180864	64mm	Diamond Core Bit
TC180870	70mm	Diamond Core Bit
TC180876	76mm	Diamond Core Bit
TC180898	98mm	Diamond Core Bit
TC1808121	121mm	Diamond Core Bit
TC1808127	127mm	Diamond Core Bit



Ideal for;

- » Glass
- » Ceramics
- » Porcelain
- » Limestone
- » Slate
- » Marble
- » Granite
- » Quartz
- » Fibreglass

Glass & Tile Drills



Glass



Part No.	Size
TCGD03	3mm
TCGD04	4mm
TCGD05	5mm
TCGD06	6mm
TCGD08	8mm
TCGD10	10mm
TCGD12	12mm
TCGD5PC	5 Pce Set

3, 4, 5, 6 & 8mm



4 Flute Glass Drill



Part No.	Size
TCGDX03	3mm
TCGDX04	4mm
TCGDX05	5mm
TCGDX06	6mm
TCGDX08	8mm
TCGDX10	10mm
TCGDX12	12mm
TCGDX4PC	4 Pce Set

4, 5, 6 & 8mm



INSTRUCTIONS FOR DRILLING IN GLASS

Glass has to lay down on a leveled, not too hard surface. Glass should never be drilled completely from one side, always from both sides to prevent glass from flaking. To avoid overheating when drilling and splinters of glass in your eyes, ALWAYS WEAR SAFETY GOGGLES (see our range on Page 104), and you must use an oily liquid as a coolant & lubricant, eg. paraffin. Drilling in glass is a slow operation! You have to work really carefully! The revolutions when drilling should not exceed 100 rpm. To fix hinges in a glass door you need really good drilled holes. We recommend shatter-proof glass for this.



Part No. TCGC001
Glass Cutter
Tungsten Carbide Wheel

Countersinks

Part No.	Size
T CS101	6mm (1/4")
T CS102	10mm (3/8")
T CS103	12mm (1/2")
T CS104	16mm (5/8")
T CS105	19mm (3/4")

Part No.	Size
T CS201	6mm (1/4")
T CS202	10mm (3/8")
T CS203	12mm (1/2")
T CS204	16mm (5/8")
T CS205	19mm (3/4")

INDUSTRIAL

HSS

- Countersink, deburr and chamfer in iron, steel, plastic and wood
- 5-Flute design with 90 degree point for smooth chamfering
- 1/4" shank fits all drills

CARBON STEEL

- Countersink, deburr and chamfer in plastic and wood
- 1-flute design with point for smooth chamfering
- 1/4" shank fits all drills



Part No. T CS005
5 Pce HSS Countersink Set
1/4" Shank
Sizes: 8, 12, 16, 19mm
w/Hex Shank Adaptor



STANDARD

Part No. T CS300
HSS Countersink 12mm
90° on Plastic Handle
» Min. cutting size 5mm
» Max. cutting size 12mm
Suitable for use on steel
& wood plate

Step Drills

Part No.	Size
TC353040	Step Drill HSS 4 - 12mm x 1mm
TC353041	Step Drill HSS 4 - 12mm x 2mm
TC353042	Step Drill HSS 6 - 18mm x 2mm
TC353043	Step Drill HSS 4 - 22mm x 2mm
TC353044	Step Drill HSS 5 - 35mm x 2 - 3mm
TC353045	Step Drill HSS 4 - 22mm x 2mm Spiral
TC353046	Step Drill HSS 3 - 35mm x 2 - 3mm Spiral
T9950	Step Drill HSS 3 Pce Set in Metal Box
TC373101-2	Step Drill HSS 3 Pce Set in Blister

INDUSTRIAL

STEP DRILLS

- » Use one drill for many hole sizes.
- » Multiple step and countersink tool for drilling and countersinking in one smooth operation.
- » Suitable for materials with a maximum thickness of 4 - 6mm, dependant on hardness.
- » The use of cutting paste is recommended.
- » The best type of drill for steel plate.
- » Burr-free holes
- » Perfectly round holes
- » Easy to enlarge holes
- » Stronger - more rigid
- » Drills plastic easily
- » Non-slip points



Spiral Step Drill
TC353045
TC353046



Tungsten Rotary Burrs



For use on pneumatic air tools and electric die grinders.
For cleaning welding seams, de-burring, grinding and shaping



#	Part No.	Width x Length	Description
1	TCBU10606	6 x 16mm	Rotary Tungsten Burr Cylindrical
2	TCBU10612	12 x 25mm	Rotary Tungsten Burr Cylindrical
3	TCBU11606	10 x 25mm	Rotary Tungsten Burr Round Point
4	TCBU11612	16 x 36mm	Rotary Tungsten Burr Round Point
5	TCBU20606	6 x 18mm	Rotary Tungsten Burr Cylindrical w/Bottom Cutter
6	TCBU20612	12 x 25mm	Rotary Tungsten Burr Cylindrical w/Bottom Cutter
7	TCBU21606	8 x 7mm	Rotary Tungsten Burr 60 Degree Cone
8	TCBU21612	12 x 10mm	Rotary Tungsten Burr 60 Degree Cone
9	TCBU30606	6 x 18mm	Rotary Tungsten Burr Conical Straight
10	TCBU30612	12 x 25mm	Rotary Tungsten Burr Conical Straight
11	TCBU31606	6 x 3mm	Rotary Tungsten Burr 90 Degree Cone
12	TCBU31612	12 x 6mm	Rotary Tungsten Burr 90 Degree Cone
13	TCBU40606	6 x 18mm	Rotary Tungsten Burr Conical Curved
14	TCBU40612	12 x 25mm	Rotary Tungsten Burr Conical Curved
15	TCBU41606	8 x 10mm	Rotary Tungsten Burr Inverted Cone
16	TCBU41612	16 x 16mm	Rotary Tungsten Burr Inverted Cone
17	TCBU50606	6 x 5mm	Rotary Tungsten Burr Tungsten Ball
18	TCBU50612	12 x 10mm	Rotary Tungsten Burr Tungsten Ball
19	TCBU60606	6 x 16mm	Rotary Tungsten Burr Round Point
20	TCBU60612	12 x 25mm	Rotary Tungsten Burr Round Point
21	TCBU70606	6 x 16mm	Rotary Tungsten Burr Conical
22	TCBU70612	12 x 28mm	Rotary Tungsten Burr Conical
23	TCBU80606	6 x 18mm	Rotary Tungsten Burr Round Point
24	TCBU80612	12 x 25mm	Rotary Tungsten Burr Round Point
25	TCBU90606	6 x 10mm	Rotary Tungsten Burr Rounded
26	TCBU90612	12 x 20mm	Rotary Tungsten Burr Rounded

INDUSTRIAL

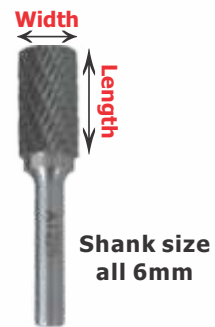

Tungsten Rotary Burr Sets



Part No.	Size	Description
M6501	5 Pce	6mm Assorted Tungsten Rotary Burrs
M6502	5 Pce	8mm Assorted Tungsten Rotary Burrs
M6504	5 Pce	12mm Assorted Tungsten Rotary Burrs



Rotary Files / Rotary Rasps



Mild Steel



Hard & Softwood

Part No.	Description
TC RF01	Round end
TC RF02	Conical
TC RF03	Ball
TC RF04	Cylindrical
TC RF05	V Point
TC RF06	V Point
TCRFS05	5 Pce Rotary File Set

CARDED



Application/Material

- For rasping or filing soft metal

Features/Benefits

- Special alloy steel is hardened and tempered for long life
- Precision cutting edges will not clog or load up
- 1/4" Shank fits all drills



Part No.	Description
TC RR01	Straight
TC RR02	Cylindrical
TC RR03	Round End
TC RR04	Conical
TC RR05	Ball End
TC RR06	Conical
TC RR07	3-in-1 Cylindrical/20mm Holesaw/15mm Plug Cutter
TC RR08	3-in-1 Cylindrical/25mm Holesaw/20mm Plug Cutter
TCRRS05	5 Pce Rotary Rasp Set

CARDED



Application/Material

- For rasping or filing wood

Features/Benefits

- Special alloy steel is hardened and tempered for long life
- Precision cutting edges will not clog or load up
- 1/4" Shank fits all drills



Titanium Drill Saws



Hard & Softwood



Mild Steel

Part No.	Size	Description
TC362003	4mm	Titanium Coated Carded
TC362004	5mm	Titanium Coated Carded
TC362009	6mm	Titanium Coated Carded
TC362013	8mm	Titanium Coated Carded
TC362017	10mm	Titanium Coated Carded
TC362018	3,4,5,6,8	HSS Set Titanium Coated

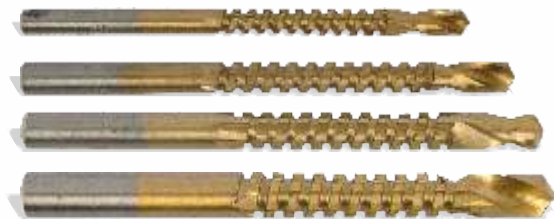

Application/Material

- For drilling and rasping in wood and steel
- For enlarging holes and shapes

1-Speed Angle Drive

Part No. TCAD01

1-Speed Angle Drive w/handle for right or left hand use & 10mm (3/8")
Chuck key 90° drive attachment



Chucks



Hardened steel body and jaws for long life

CM13



CM20-5



Part No. CM16-2
Keyed Chuck 16mm
1.0 - 16mm
with B16 Taper



Part No. CMH06
1/4" Hex Shank Chuck
0.6 - 6mm

Part No. Description

CM10	Chuck & Key 10mm 3/8" x 24
CM13	Chuck & Key 13mm 1/2" x 20
CM13-1	Chuck & Key 1 - 13mm B16
CM13-5	Chuck & Key 1.5 - 13mm 1/2" x 20 Colour Box
CM16	Chuck & Key 16mm JT3 Taper
CM16-4	Chuck & Key 1 - 16mm 5/8"-16 UNF Heavy-duty
CM20-5	Chuck & Key 5 - 20mm B22 Taper



Part No. CM13-5

Part No. CM99
Locking screw for chucks
Reverse thread
Bulk



Keyless Chucks

Part No. Description

CM10-2	10mm with 3/8" x 24 UNF
CM10-3	10mm with 3/8" x 24 UNF Single sleeve Self-Lock
CM13-2	13mm with 1/2" x 20 UNF
CM13-3	13mm x 1/2" x 20 UNF : Metal knurled ring
CM13-4	13mm x 1/2" x 20 UNF : Self-tightening
CM16-3	16mm B16 Taper with lock : Precision chuck

Convenient and easy to use, no chuck key to lose.
Keyless for easier chucking and bit changes. Best for rotary drilling.



CM10-2



CM10-3



CM13-2



CM13-3



CM13-4



CM16-3

Chuck Adaptors



Part No. CM113

Chuck & Key 13mm 1/2" UNF
& SDS Adaptor
- Fits all SDS Plus machines

NB. NOT FOR SDS HAMMER ACTION

Part No. TC17900

SDS Plus Chuck Adaptor
with 1/2" x 20 Thread
- Fits all SDS Plus machines



CMB16

CMMT2-1

Part No. Description

CMB16	Arbor Taper Adaptor MT2 x B16
CMMT2-1	Morse Taper Sleeve MT2 - MT1
CMMT2-2	Chuck Arbor Adaptor MT2 - B22
CMMT3	Arbor Taper Adaptor MT3 x B16
CMMT3-2	Taper Sleeve MT3 - MT2
CMMT3-3	Chuck Arbor Adaptor MT3 - B22
CMJT3-1	Taper Adaptor MT2 - JT3
CMJT3-2	Taper Adaptor MT3 - JT3

INDUSTRIAL

Chuck Keys

Part No. Description

CM01	Chuck Key for 3/8"/10mm Chucks
CM02	Chuck Key for 1/2"/13mm Chucks
CM04	Chuck Key for 16mm Chucks



TORK CRAFT™ Extra Hard Screwdriving Bits



Fully hardened and tempered for long life
1/4" Shank

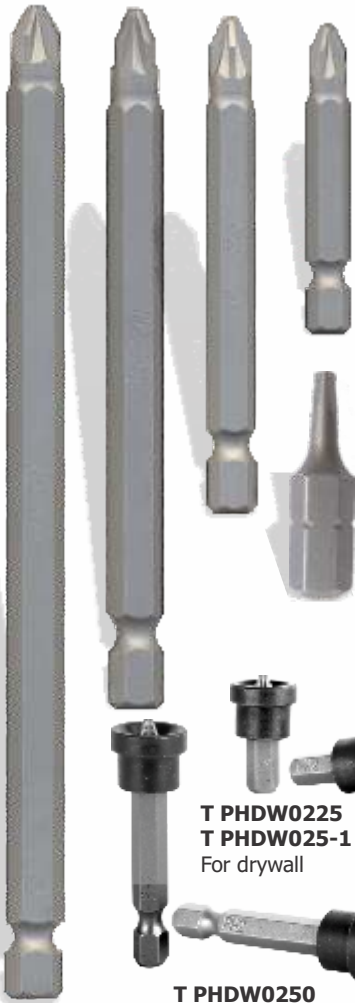

T PHDW0225
T PHDW025-1 Pouch
For drywall

T PHDW0250
T PHDW050-1 Pouch
For drywall



INSERT BITS

POWER BITS

DOUBLE ENDED BITS

	SIZE	LENGTH	2 Pc CARDED	BULK
PHILLIPS	PH1	25mm	T PH0125C	
	PH2	25mm	T PH0225C	T PH0225B
	PH3	25mm	T PH0325C	
POZI	PZ1	25mm	T PZ0125C	T PZ0125B
	PZ2	25mm	T PZ0225C	T PZ0225B
	PZ3	25mm	T PZ0325C	T PZ0325B
SLOTTED	3mm	25mm	T SL0325C	
	4mm	25mm	T SL0425C	
	5mm	25mm	T SL0525C	
	6mm	25mm	T SL0625C	
	8mm	25mm	T SL0825C	
SQUARE RECESS	0	25mm	T SQ0025C	T SQ0025B
	1	25mm	T SQ0125C	T SQ0125B
	2	25mm	T SQ0225C	T SQ0225B
	3	25mm	T SQ0325C	T SQ0325B
TRIANGULAR		25mm	T SCTR01-2	T SCTR01
TORX TAMPER PROOF			TTP302510 (10mm Hex Shank)	
T30		25mm	T TR001C	T TR001
TRIWING		25mm	T TR002C	T TR002
		25mm	T TR003C	T TR003
		25mm	T TR004C	T TR004
		25mm	T TR004C	T TR004
PHILLIPS	PH1	50mm	T PH0150C	
	PH2	50mm	T PH0250C	T PH0250B
	PH2	70mm		T PH0270B
	PH2	150mm	T PH02150C	T PH02150B
	PH3	50mm	T PH0350C	
	PH2	25mm	T PHDW025-1	T PHDW025
	PH2	50mm	T PHDW050-1	T PHDW050
POZI	PZ1	50mm	T PZ0150C (1pc)	T PZ0150B
	PZ2	50mm	T PZ0250C	T PZ0250B
	PZ2	70mm		T PZ0270B
	PZ2	89mm		T PZ0289B
	PZ2	150mm	T PZ02150C	T PZ02150B
	PZ3	50mm	T PZ0350C	T PZ0350B
SLOTTED	3mm	50mm	T SL0350C	
	4mm	50mm	T SL0450C	
	5mm	50mm	T SL0550C	
	6mm	50mm	T SL0650C	
	8mm	50mm	T SL0850C	
	10mm	50mm	T SL1050C	
	SQUARE RECESS	No. 0	50mm	T SQ0050C
No. 1		50mm	T SQ0150C	T SQ0150B
No. 2		50mm	T SQ0250C	T SQ0250B
No. 3		50mm	T SQ0350C	T SQ0350B
No. 1		150mm	T SQ01150C	T SQ01150B
No. 2		150mm	T SQ02150C	T SQ02150B
No. 3		150mm	T SQ03150C	T SQ03150B
PH1 x PH1		65mm	T PH0165C	
PH2 x PH2		45mm	T PH0245C	
PH2 x PH2	65mm	T PH0265C	T DE PH0265B	
PH2 x SL.5	45mm	T PHS0245C		
PH2 x SL.5	65mm	T PHS0265C	T DE PHSL65B	
PZ1 x PZ1	65mm	T PZ0165C		
PZ2 x PZ2	45mm	T PZ0245C		
PZ2 x PZ2	65mm	T PZ0265C	T DE PZ0265B	
PZ2 x SL.5	45mm	T PZS0245C		
PZ2 x SL.5	65mm	T PZS0265C	T DE PZSL65B	

INDUSTRIAL

Impact Magnetic Bit Holder

Length	Carded	INDUSTRIAL
1/4" x 57mm	TCIBH54C	
1/4" x 76mm	TCIBH75C	



Impact Magnetic Nutsetter

Length	Carded	Bulk
5/16" x 65mm	TCINS51665C	TCINS01
8 x 65mm	TCINS08065C	
3/8" x 65mm	TCINS38065C	
10 x 65mm	TCINS10065C	



Impact Power Bit Phillips

Length	Carded	Bulk	INDUSTRIAL
PH1 X 25mm	TCIPH0125C		
PH1 X 50mm	TCIPH0150C		
PH2 X 25mm	TCIPH0225C	TCIPH0225B	
PH2 X 50mm	TCIPH0250C	TCIPH0250B	
PH3 X 25mm	TCIPH0325C		
PH3 X 50mm	TCIPH0350C		



Phillips



TCIPH022515



15 Pc Tic Tac Case
Impact Power Bits
PH2 x 25mm

TCIPH025015



15 Pc Tic Tac Case
Impact Power Bits
PH2 x 50mm

Impact Power Bit Pozzi

Length	Carded	Bulk	INDUSTRIAL
PZ1 X 25mm	TCIPZ0125C		
PZ1 X 50mm	TCIPZ0150C		
PZ2 X 25mm	TCIPZ0225C	TCIPZ0225B	
PZ2 X 50mm	TCIPZ0250C	TCIPZ0250B	
PZ3 X 25mm	TCIPZ0325C		
PZ3 X 50mm	TCIPZ0350C		



Pozzi



TCIPZ022515



15 Pc Tic Tac Case
Impact Power Bits
PZ2 x 25mm

TCIPZ025015



15 Pc Tic Tac Case
Impact Power Bits
PZ2 x 50mm

Impact Square Recess Bit

Length	Carded	Bulk	INDUSTRIAL
SQ1 X 25mm	TCISQ0125C		
SQ1 X 50mm	TCISQ0150C		
SQ2 X 25mm	TCISQ0225C	TCISQ0225B	
SQ2 X 50mm	TCISQ0250C	TCISQ0250B	
SQ3 X 25mm	TCISQ0325C		
SQ3 X 50mm	TCISQ0350C		



Square Recess



TCISQ022515



15 Pc Tic Tac Case
Impact Power Bits
SQ2 x 25mm

TCISQ025015



15 Pc Tic Tac Case
Impact Power Bits
SQ2 x 50mm

Quick Change Bit Holder

TCQCH06514
Quick Change Bit Holder 1/4" 65mm Carded

INDUSTRIAL



One Touch Magnetic Bit Holder

Length	Carded	INDUSTRIAL
75mm	T BH2101075	
150mm	T BH21010150	
300mm	T BH21010300	
T SD2071180	SDS Plus 80mm	
T SD21680	SDS Plus 80mm	



Magnetic Bit Holder & 1/4" Extension

Length	Carded	Bulk	INDUSTRIAL
54mm	T BH54C	T MBH54B	
60mm		T MBH60B	
75mm	T BH75C	T MBH75B	
90mm	T BH30090		
100mm	T BH30100		
100mm	T BH03100A		



Strong one-piece design for long life

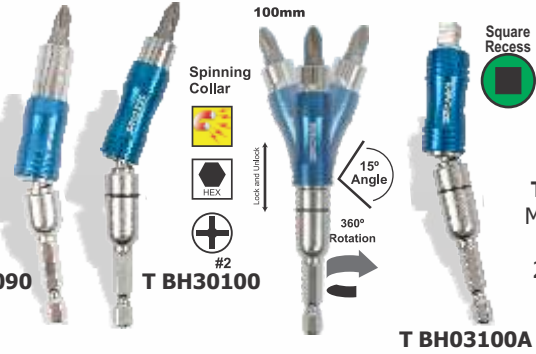

TCMSH02114
Magnetic Screw Holder 1/4" 21mm Carded

Magnetic Nutsetters

Size	Length	Carded	Bulk	INDUSTRIAL	
Imperial					
5/16"	42mm	T NS51642C	T NS03		
5/16"	65mm	T NS51665C	T NS01		
3/8"	45mm	T NS38045C	T NS04		
3/8"	65mm	T NS38065C	T NS02		
Metric					
6mm	100mm	TNS201	TNS206100C		
8mm	100mm	TNS202	TNS208100C		
10mm	100mm	TNS203	TNS210100C		
12mm	100mm	TNS204	TNS212100C		
13mm	100mm	TNS205	TNS213100C		
3/8"	100mm	TNS206	TNS238100C		
5/16"	100mm	TNS207	TNS2516100C		
8mm	48mm		TCNNS08048C		
10mm	48mm		TCNNS10048C		
3/8"	48mm		TCNNS38048C		
5/16"	48mm		TCNNS51648C		

Size	Length	Carded	Bulk
Metric			
5.5mm	65mm		T NS11
6mm	65mm	T NS06065C	T NS10
7mm	65mm	T NS07065C	T NS08
8mm	65mm	T NS08065C	T NS05
10mm	65mm	T NS10065C	T NS06
12mm	65mm	T NS12065C	T NS07
13mm	65mm	T NS13065C	T NS09
14mm	65mm	T NS14065C	T NS14

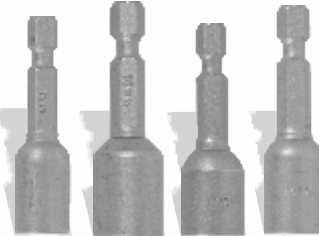

- » Universal 1/4" Hex Shank with power groove
- » Magnetic bit holds fastener
- » Ideal for fast, easy driving of nuts, bolts & hex held screws

Socket Adaptors

Size	Length	Carded	Bulk	INDUSTRIAL
1/4" Hex x 1/4" Square	25mm	T AD14014C	T AD14014B	
1/4" Hex x 1/4" Square	50mm	T AD14050C		
1/4" Hex x 1/4" Square	75mm		T AD14075B	
1/2" Square SDS	75mm	T AD31012		
3/8" Square SDS	65mm	T AD31038		
1/4" Hex x 3/8" Square	50mm	T AD38050C	T AD38050B	
1/4" Hex x 1/2" Square	50mm	T AD12050C	T AD12050B	

- Converts drill into a power nutsetter
- Ideal for fast, easy driving of nuts, bolts and hex head screws
- 1/4" shank fits all variable-speed drills



Screw Guide

Part No. TZ AC23 Magnetic Screw Guide & Extension 1/4"
120mm long Magnetic bit holder holds 6.35mm (1/4") hex shank insert bits. Outer self-retracting sleeve easily and quickly holds and guides the screw straight into the timber and helps to eliminate any slippage while driving.

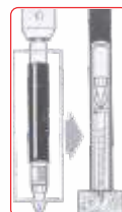

Screw Pilots

Part No.	Size
T SP06075C	# 6 x 75mm
T SP08075C	# 8 x 75mm
T SP10075C	# 10 x 75mm
T SP12075C	# 12 x 75mm
T SP05000C	5 Pce Set with #6, 8, 10, 12 plus 1 x Allen Key
T SP24	Replacement Drill Bit 2.4mm for Screw Pilot #6
T SP28	Replacement Drill Bit 2.8mm for Screw Pilot #8
T SP32	Replacement Drill Bit 3.2mm for Screw Pilot #10
T SP35	Replacement Drill Bit 3.5mm for Screw Pilot #12

- Fast countersinking and counter boring in one operation
- Drills in wood, plastic and composition material
- Replaceable drill bit

Part No.	Size
TZ AC26-6	#6 X 7/64" (2.8mm) Screw pilot
TZ AC26-8	#8 x 1/8" (3mm) Screw pilot
TZ AC26-10/12	#10-12 x 5/32" (4mm) Screw pilot
TZ AC26	3 Pce Set with #6, #8 & #10
TZ AC26-02	Allen Key for TZ AC26
TZ AC27-B	Hex Shank Drill Bit 2.5mm x PZ1

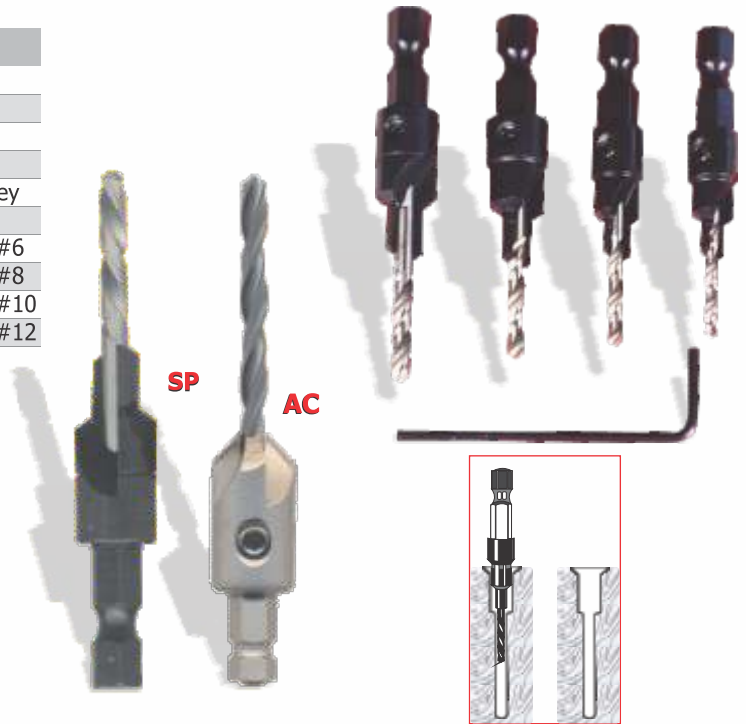

Flexible Shaft Bit Holder

Part No. TCFS200

Flexible Shaft Bit Holder : Overall length 200mm (8") Hex 1/4" M x 1/4" F
For Hand or Power Drill Use



Dimpler

Part No. DIM001

- » For driving drywall screws PH2
- » Auto clutch fits any drill

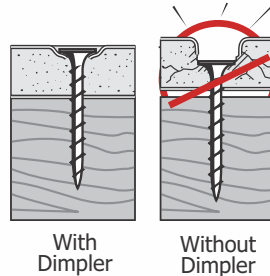
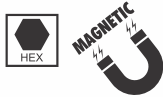
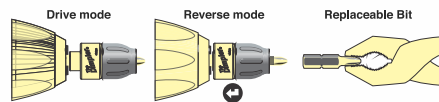

Converts your electric drill into a professional screwgun! Countersink screws fast & accurately

A must for drywall...prevents screwhead from penetrating too far & tearing through the paper layer & weakening its core

Features a powerful magnet

www.drywalldriver.com/torkcraft

Even Pilot Clutch System

Part No. TZ AC11 : The Even Pilot 1/4"

A unique accessory that converts any electric drill into a powerful "screw gun". Easy depth adjustment enables precise countersinking and counter boring of screws in drywall particleboard & plywood. Quick & easy change without re-chucking. Max RPM 2500.

Part No. TZ AC11A The Even Pilot Plus 1/4"

The ideal for clutch screw driving.

Can also be used with self-drilling screws on corrugated steel materials.

Adjustable depth stop.

Use with magnetic nut-driver in sizes of 1/4" & 5/16".

Free rotating ring to hold & guide screw in accurately.

Automatic clutch release enables precise countersinking of screws in drywall, particle board and plywood.



TORK CRAFT™ Decking Tool

Part No.	Description
TCDT008-01	Decking Tool 8G Standard Head Pre-Drill & Countersink (comes with 2 x Repl. Bits)
TCDT008-02	Replacement Drill Bit for Decking Tool 8G - x 5Pce
TCDT010-01	Decking Tool 10G Standard Head Pre-Drill & Countersink (comes with 2 x Repl. Bits)
TCDT010-02	Replacement Drill Bit for Decking Tool 10G - x 5Pce
TCDT012-01	Decking Tool 12G Standard Head Pre-Drill & Countersink (comes with 2 x Repl. Bits)
TCDT012-02	Replacement Drill Bit for Decking Tool 12G - x 5Pce



HSS Parabolic Bits
for **FASTER** drilling

DECKING TOOL, the ultimate all-in-one pre-drilling countersink tool!
Purpose built for decking and woodworking applications, especially where stainless steel screws are used. The single drilling countersinking action of the tool allows for an easier, quicker and more professional looking finish.

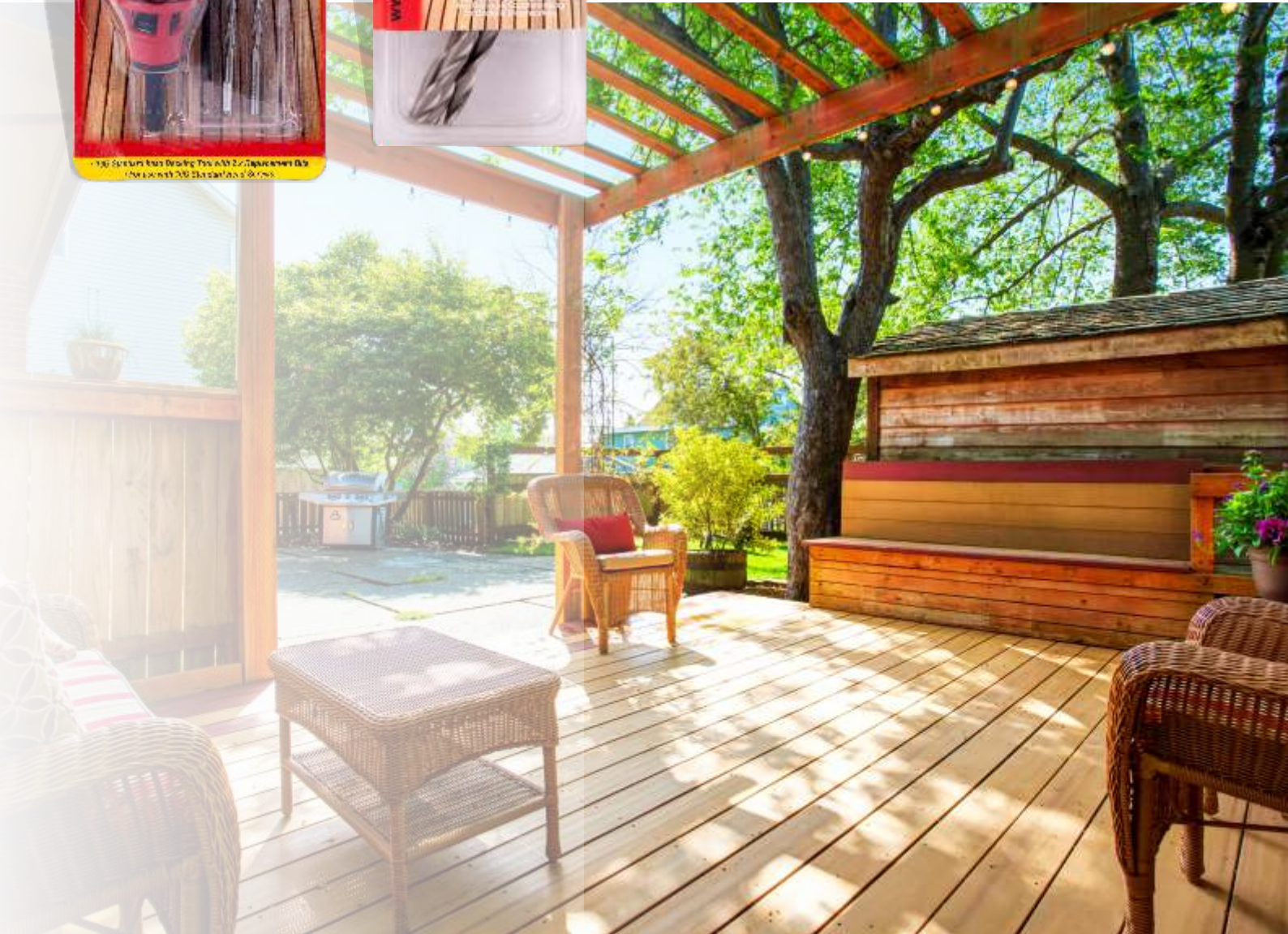
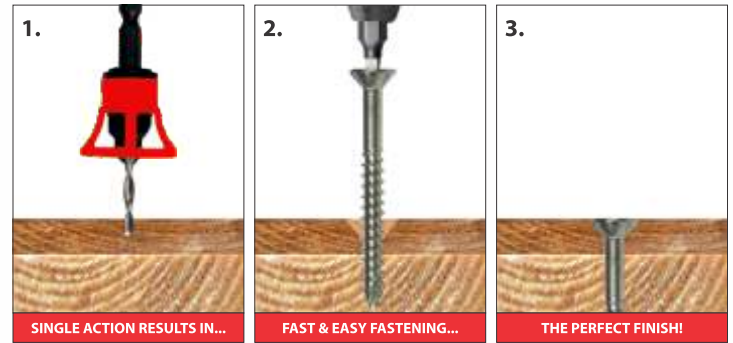

Screwdriving Bits & Insert Bits

Part No.	Description	INDUSTRIAL
T PH022510	10 Pce Screwdriver Bit Set PH2 x 25mm	
T PZ022510	10 Pce Screwdriver Bit Set PZ2 x 25mm	
T PH25015	15 Pce Compact Bit Set PH2 x 25mm	
T PZ025010	10 Pce Screwdriver Bit Set PZ2 x 50mm	

Part No.	Description	INDUSTRIAL
SSPH0250BR	PH2 x 50mm Stainless Steel Reduced Shank	
SSPZ0225B	PZ2 x 25mm Stainless Steel	
SSPZ0250BR	PZ2 x 50mm Stainless Steel Reduced Shank	
SSSQ0250BR	SQ2 x 50mm Stainless Steel Reduced Shank	

Complete range of styles and sizes
Ideal complement for any electric drill or screwdriver
Standard 1/4" Hex shanks



TIN COATED TORSION BIT

Part No. T PZ0225TINB
PZ #2 x 25mm Tin Coated Torsion Bit
Part No. T PZ0225TINC
PZ #2 x 25mm Tin Coated Torsion Bit (2 Pce)

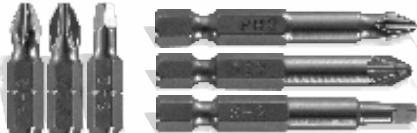

Prevent rust when
working with Stainless Steel
For use with Stainless Steel screws

Screwdriving Bit Sets



Part No. T SC06045C
6 Pce 45mm Double End Bit Set on Skin card
Contents:
PH1 x PZ1, PH2 x PZ2, PH3 x PZ3
SL3 x SL5, SL4 x SL6, SL5 x SL7



Part No. T SC50005C
5pce 50mm long S2 Power Bit Set in Blister pack
Contents:
1 x PH1, 1 x PH2, 1 x PH3
1 x PZ1, 1 x PZ2



Part No. T SC06504C
4PC 65mm Double End Bit set in Skin Card.
Contents:
PH1 X PZ1, PH2 X PZ2
Slotted 3mm x 5mm, Slotted 4mm x 6mm



Part No. T SC10006C
6pce 100mm long Power Bit Set
Long series for hard to reach screws
Contents:
Phillips: 1 x PH1, 1 x PH2
Pozi: 1 x PZ1, 1 x PZ2
Slotted: 1 x 4mm, 1 x 5mm



Part No. T SC06506C
6PC 65mm Double End Bit set in Skin Card.
Contents:
PH1 x PZ1, PH2 x PZ2, PH3 x PZ3
Slotted 3mm x 5mm, 4mm x 6mm, 5mm x 7mm

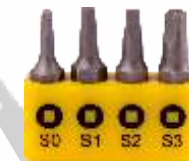

Part No. TZ SQ250401C
4 Pce 25mm Square Recess Bit Set
Contents:
SQ #0, 1, 2, 3



Part No. T SC06510C
10 Pce 65mm Double End Bit Set
on Skin card
Contents:
PH1 x PH1, 2 x PH2 x PH2, PH2 x PH2,
PZ1 x PZ1, PZ2 x PZ2, PZ3 x PZ3



Part No. TZ SQ500401C
4 Pce 50mm Square Recess Bit Set
Contents:
SQ #0, 1, 2, 3



Part No. T SC25007C
7 Pce Compact Case Set in Blister Pack
Contents:
25mm;
1 x PH2, 1 x PZ1, 1 x PZ2,
1 x 4mm, 1 x 6mm, 1 x SQ2
1 x Bit Holder



Screwdriving Bit Sets

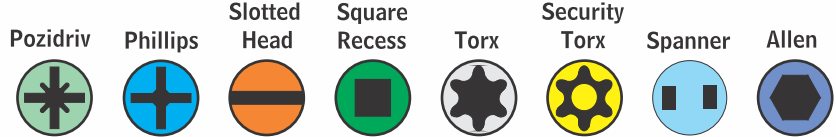

Part No. TC02510
10 Pce Screwdriver Bit Set
Phillips, POZI & Slotted &
1 x Magnetic Bit Holder



Part No. TC02507
7 Pce Screwdriver Bit Set
Phillips: 1 x PH1 & PH2
Pozi: 1 x PZ1 & PZ2
Slotted: 1 x SL6 & SL7
1 x Magnetic Bit Holder



Part No. TC02531
31 Pce Screwdriver Bit Set
30 x Assorted bits
1 x Magnetic Bit Holder



Part No. T SC25020C
20pce Handy Bit Box on Sliding Card
Contents:
Phillips: #1, #2, #3
Pozi: #1, #2, #3
Slotted: 4, 5, 6 & 7mm
Torx: 10, 15, 20, 25, 30 & 40
Hex: 3, 4, 5 & 6



Part No. KT1115
15 Pce Screwdriver Set
Set consists of;
1 Pce Screwdriver Bit Holder
8 Pce 25mm CRV bits:
PH1, PH2
SL4.5mm, SL7mm
PZ1, PZ2
TX15, TX20
5 Pce 1/4" Drive Sockets
6, 7, 8, 9 & 10mm
1 Pce Adaptor



Part No. T SC25010C
10pce 25mm long S2 Insert Bit Set in Blister Pack
Contents:
Pozi 1 x PZ1, 1 x PZ2, 1 x PZ3
Phillips 1 x PH1, 2 x PH2, 1 x PH3
Slotted 1 x 4mm, 1 x 5mm, 1 x 6mm



Part No. TZ MG G2201
19pce 1/4" Drive Bit Kit
Contents:
- 1 Bit Holder 75mm with finder sleeve
- 16 Insert Bits (25mm)
- 2 Socket Adaptors (25mm & 50mm)



Part No. KT2813
37 Pce Combined Tool Set
Contents;
1 x Offset Ratchet Box Wrench
1 x Quick Release Chuck
SL 3, 4, 5, 6, 7mm
PH0, 2 Pce x PH1, PH2 & PH3
PZ0, PZ1 x 2Pc, PZ2 x 2Pc
S0, S1, S2, S3
T10, 15, 20, 25, 27, 30, 40
H2, 2.5, 3, 4, 5, 5.5, 6

Screwdriving Bit Sets



Part No. KT7124
24 Pce Screwdriver Bit & Socket Set
Contents;
1 x T-Handle
9 x 1/4" Drive Sockets
5, 6, 7, 8, 9, 10, 11, 12, 13mm
4 x 25mm
Slotted : SL5, SL6, SL7 & SL8
Phillips : PH1, PH3 & 2 x PH2
Torx : TX10, TX15 & TX20
Square : #1 & #2
1 x Adaptor

INDUSTRIAL

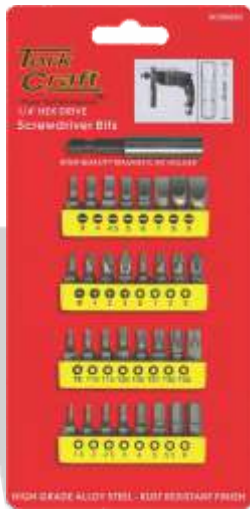

Part No. T SC25033C
33pce 25mm long Insert Bit Set
Contents:

- 8 Piece Slotted: 3, 4, 4.5, 5, 6, 7, 8, 9mm
- 8 Piece PH/PZ: PH: 0, 1, 2, 3 PZ: 0, 1, 2, 3
- 8 Piece Hex: 1.5, 2, 2.5, 3, 4, 5, 5.5, 6mm
- 8 Piece Torx: 8, 10, 15, 20, 25, 27, 30, 40
- 1 x Zinc Bit Holder



T SC250081C
8 Pce Screwdriver Bit Set
25mm Slotted Bits
3, 4, 4.5, 5, 6, 7, 8 & 9mm



T SC25008C
8 Pce 25mm S2 Insert Bit Set
on Sliding Card
Contents :

- 1 x PH0, 1 x PH1, 1 x PH2, 1 x PH3
- 1 x PZ0, 1 x PZ1, 1 x PZ2, 1 x PZ3



T SC250082C
8 Pce Screwdriver Bit Set
25mm Torx Bits
T8, T10, T15, T20, T25, T27, T30 & T40



T SC25018C
8 Pce 25mm S2 Insert Bit Set
on Sliding Card
Contents : Tamper Resistant Torx Bits
T8, T10, T15, T20, T25, T27, T30 & T40



T SC250083C
8 Pce Screwdriver Bit Set
25mm Hex Bits
1.5, 2, 2.5, 3, 4, 5, 5.5 & 6mm



Specifications
» High grade alloy steel
» Rust resistant sand blasted finish
» Use with TorkCraft bit holders
T BH54C/T BH60C/T BH75C



Part No. T SC50012C
Drill Strap with 50mm Power Bit Set 12 Pcs



Screwdriving Bit Sets



Part No. KT6241

41 Pce Screwdriver Ratchet Set

Contents:

- 1 x Ratchet Screwdriver, 1 x 25mm Adaptor, 1 x Precision Bit Driver, 1 x Bits Driver
- 9 x 1/4" Drive Sockets: 5, 6, 7, 8, 9, 10, 11, 12, 13mm
- 12 Pce Precision Bits: 4 x 25mm
- Slotted : SL2, SL2.5 & SL3mm / Phillips : PH0, PH00, PH000
- Torx : TX5, TX6 & Tx7 / Hex : 1.3, 2 & 2.5mm
- 16 Pce Bits: 6.35 x 25mm
- Slotted : SL3, SL4, SL5 & SL6 / Torx : TX10, TX15, TX20 & TX25
- Square : 0, 1, 2, 3mm / Phillips : PH0, PH1, PH2 & PH3



- » Chrome Vanadium blade
- » Magnetized Tip
- » Soft handle for secure grip



Part No. KT6242

37 Pce Screwdriver Ratchet Set

Contents:

- 1 Pce Ratchet Screwdriver
- 26 Pce Bits (6.35 x 25mm)
- 1 Pce ADP (25mm)
- 9 Pce 1/4" Sockets
- Sizes; 5, 6, 7, 8, 9, 10, 11, 12, 13

Part No. KT6239
39 Pce Bit Set
w/Quick Release Bit Holder

Contents:

- » 1 Pc Magnetic Holder
- » 7 Pc Bits (6.35 x 50mm)
4mm, 5mm, 6mm
PH0, PH1, PH2, PH3
- » 31 Pc Bits (6.35 x 25mm)
3mm, 4mm, 2 x 5mm, 2 x 6mm
PH0, 2 x PH1, 2 x PH2, PH3
T10, T15, T20, T25, T27, T30, T35
PZ0, PZ1, PZ2, PZ3
2 x S0, S2, S3
H3, H4, H5, H6

- » Easy bit changes
- » Made of high degree special steel



Part No. KT2573

101 Pce Bit Set

Set consists of;

- 4 x Slotted, 9 x Phillips, 8 x Pozidrive, 13 x Torx, 19 x Hex,
- 3 x Spline M-Type, 4 x Square, 4 x Spanner, 3 x Torq,
- 4 x Three Wings, 9 x Torx with hole, 12 x Hex with hole,
- 3 x Clutch, 1 x 25mm & 1 x 50mm Adaptor, 1 x Hook Adaptor,
- 1 x 60mm Magnetic Bit holder, 1 x Ratchet Screwdriver
- 1 x 1/4" Coupler

Part No. KT2301
20 Pce Screwdriver Set
includes Insert Bits
w/Quick Release Bit Holder

Contents:

- » 5 x Screwdrivers
- » 1 Bitholder with handle
- » 14 Pc Bits - Hex/Pozi/Slotted



Screwdriving Bit Sets



Part No. KT7001
Portable 4-in-1 Screwdriver Set
PH & SL
Comes with;
» LED Light
» Belt Clip
» Key Ring



Part No. JJBS18
18 Pce Flexible Shaft & Accessories Set



Part No. TC700310
23 Pce Combination Drill & Screwdriving Set



Part No. JJBD27
27 Pce Drill & Screwdriving Set



Ratchet Screwdrivers



Part No. KT6231 Screwdriver
31 Pce Ratchet Screwdriver T-Handle Bit Set
Contents:
» 1 Pc Ratchet Screwdriver
» 1 Pc ADP (25mm)
» 20 Pc Bits (6.35 x 25mm)
● 3mm, 4mm, 5mm, 6mm, 7mm
⊕ PH0, PH1, PH2, PH3
⊕ PZ0, PZ1, PZ2, PZ3
⊕ T10, T15, T20, T25, T27, T30, T40
» 9 Pc 1/4" Socket
● 4mm, 5mm, 6mm, 7mm, 8mm, 9mm, 10mm, 11mm, 12mm

Part No. TZ RH2 Screwdriver
Reversible Ratchet Screwdriver with pivot action for all angle drive & 10 x 25mm insert bits
PZ: 1, 2, 3 **PH:** 1, 2, 3
SL: 5, 6 **Torx:** T15, T20













Magnetic Screwdriver

Part No. T 938001
1/4" Hex Magnetic Screwdriver Bit Holder CD



Part No. KT2675
14 in 1 Ratchet Screwdriver with 13 x 25mm insert bits & 1 x 60mm Bit Holder
PH: 0, 1, 2, 2, 3 **SL:** 3, 4, 5, 6 **HEX:** 2, 3, 4, 5

Screwdrivers Black Head

PART NO.	SIZE		PART NO.	SIZE	
PHILLIPS (PH)			VDE INSULATED		
TC16000	PH 0 X 75mm		TC16031	PH 0 x 75mm	
TC16001	PH 1 x 75mm		TC16032	PH 1 x 80mm	
TC16002	PH 1 X 100mm		TC16033	PH 2 x 100mm	
Tc16003	PH 1 X 150mm		TC16035	PZ 0 x 75mm	
TC16004	PH 2 x 38mm		TC16036	PZ 1 x 80mm	
TC16005	PH 2 x 100mm		TC16037	PZ 2 x 100mm	
TC16006	PH 2 x 150mm		TC16039	SL 0.6 x 3.5 x 75mm	
TC16007	PH 2 x 250mm		TC16040	SL 0.8 x 4 x 100mm	
TC16008	PH 3 x 150mm		TC16041	SL 1.0 x 5.5 x 125mm	
TC16009	PH 3 x 200mm				
TC16082	PH 2 x 300mm		TC16042	SL 1.2 x 6.5 x 150mm	
POZI			SQUARE INSULATED		
TC16012	PZ 0 x 75mm		TC16074	1 x 80mm	
TC16013	PZ 1 x 75mm		TC16075	2 x 100mm	
TC16014	PZ 2 x 100mm		TORX		
TC16015	PZ 3 x 150mm		TC16045	T5 4 x 75mm	
SLOTTED			TC16046	T6 4 x 75mm	
TC16018	SL 3.2 x 75mm		TC16047	T7 4 x 75mm	
TC16019	SL 4 x 75mm		TC16048	T8 4 x 75mm	
TC16020	SL 5 x 75mm		TC16049	T9 4 x 75mm	
TC16021	SL 5 x 100mm		TC16050	T10 5 x 100mm	
TC16022	SL 5 x 150mm		TC16051	T15 5 x 100mm	
TC16023	SL 6 x 38mm		TC16052	T20 5 x 100mm	
TC16024	SL 6 x 100mm		TC16053	T25 6 x 100mm	
TC16025	SL 6 x 150mm		TC16054	T27 6 x 100mm	
TC16026	SL 6 x 250mm		TC16055	T30 6 x 100mm	
TC16027	SL 8 x 150mm		TC16056	T40 8 x 115mm	
TC16028	SL 8 x 200mm		SECURITY TORX		
Tc16080	SL 4 x 300mm		TC16060	T8 3 x 100mm	
TC16081	SL 5 x 300mm		TC16061	T9 3 x 100mm	
			TC16062	T10 5 x 100mm	
			TC16063	T15 5 x 100mm	
			TC16064	T20 5 x 100mm	
SQUARE RECESS			TC16065	T25 6 x 100mm	
T SQ10002	No. 2		TC16066	T27 6 x 100mm	
SQUARE			TC16067	T30 6 x 100mm	
TC16070	0 x 75mm		TC16068	T40 8 x 115mm	
TC16071	1 x 75mm		SPANNER BITS		
TC16072	2 x 100mm		TC16076	4 x 150mm	
TC16073	3 x 150mm		TC16077	6 x 150mm	
ALLEN KEY			TC16078	8 x 150mm	
TC16090	1.5mm Blue Handle		TC16079	10 x 150mm	
TC16091	1.5mm Red Handle				



Screwdriver Sets



Part No. KT2222
6 Pce Screwdriver Set
SL 3 x 75, 5 x 100
SQ 2 x 150mm
PZ 2 x 150, 1 x 100, 0 x 75mm
• with Wall Mountable Rack



Part No. KT2552
6 Pce Screwdriver Set
Set consists of;
SL 3 x 75, 5 x 100, 6 x 150mm
PH 2 x 150, 1 x 100, 0 x 75mm
• with Wall Mountable Rack



Part No. KT2551
6 Pce Screwdriver Set with Black Handles
Contents;
» PH0 X 75mm, PH1 x 100mm, PH2 x 150mm
» SL3 x 75mm, SL5 x 100mm, SL6 x 150mm



Part No. KT2554
4 Pce Screwdriver Set
Set consists of;
SL 5 x 100, 6 x 150mm
PH 1 x 100, 2 x 150mm



Part No. KT2301
20 Pce Screwdriver Set
Set consists of;
SL 5.5 x 75, 6 x 100,
8 x 150mm
PH 1 x 75, PH 2 x 100mm
1 Pce Bitholder with handle
14 Pce Bits 25mm
Hex : 2, 3, 4, 5, 5.5, 6
Pozi : PZ0, PZ1, PZ2, PZ3
SL : 3, 4, 5, 5.5



Part No. KT2512
12 Pce Screwdriver Set CRV
w/Black Handle
Set consists of;
3 x Slotted
3 x Phillips
3 x Pozi
3 x Torx



Screwdriver Sets

Part No. KT2906

6 Pce Wooden Screwdriver Set

- 3 x Slotted : SL8 x 150, SL6 x 100, SL5 x 75mm
- 3 x Phillips : PH3 x 150, PH2 x 100, PH1 x 75mm
- Wooden Handles with Hammer Cap & Hex Spanner Grip
- » Heat treated satin chrome-plated steel end cap for hammer use
- » Magnetic Tips
- » English Beech-wood & protective coating
- » Chrome vanadium



Part No. KT2677

6 in 1 Screwdriver

- Set consists of;
- 1 x Handle
- 1 x Double-sided bit holder
- 1 x Double-sided bit PH1 - SL 3/16
- 1 x Double-sided bit PH2 - SL 1/4
- Replacement Bits Double-ended
- Part No. KT2677-1 : 75mm PH2 - SL
- Part No. KT2677-2 : 65mm PH1 - SL

Sold as a Box of 9pc

Part No. KT2302

6 in 1 Screwdriver plus 5M Steel Measuring Tape



Extendable Screwdrivers

Part No. TZ SD02

- Flexible & Extendable Precision Screwdriver



Wire Strippers

Part No. TCWS300
3-in-1 Wire Stripper

- 4 - 10mm Round cables
- 8 - 10mm Longitudinal cutting



Part No. TCWS301
Wire Stripper Pistol Grip

- 0.2 - 6mm Round cables
- w/3mm Wire Cutter



Precision Screwdriver Sets



Part No. T878P07A
6 Pce Precision Screwdriver Set
 Phillips & Slotted
 Contents:
 PH0, PH00
 SL 2.0, 2.5, 3.0 & 4.0mm



Part No. KT2539
39 Pce Screwdriver Set w/Double Injected Handles
 10 Pce Screwdriver Bits
 ⊕ 3 x 75mm ⊕ PH0 x 75mm
 ⊕ 5 x 75mm ⊕ PH1 x 75mm
 ⊕ 6 x 100mm ⊕ PH2 x 100mm
 ⊕ 6 x 38mm ⊕ PH2 x 38mm
 ⊕ 8 x 150mm ⊕ PH3 x 150mm
 3 Pce Precision Screwdrivers
 ⊖ 1.5 x 50mm, 2.0 x 50mm
 ⊕ PH00 x 50mm
25 Pce Bits 25mm
1 Pce Bit Holder w/handle



Part No. KT2316
16 Pce Screwdriver Set
 Std & Precision in Canvas Bag
 Set consists of;
STANDARD:
 SL 5 x 75, 6 x 100, 8 x 150mm
 PH 1 x 75, 2 x 100, 3 x 150mm
PRECISION:
 SL 2.5 x 50, 3 x 50mm
 PH 0 x 50, 00 x 50mm
 TX T6 x 50, T7 x 50, T8 x 50,
 T9 x 50, T10 x 50, T15 x 50mm

Part No. KT5001
 Electric Tester Screwdriver
 30 Pcs / Candy Jar
Part No. KT5001-1
 Electric Tester Screwdriver
 30 Pcs each



KT5001-1



Part No. KT6002
29 Pce Ratcheting Screwdriver & T-Handle Tool Set
25 Pce Chrome Vanadium Driver Bits
 ⊕ » #0, #1, #2 & #3
 ⊕ » T10, T15, T20, T25 & T30
 ⊕ » PZ0, PZ1, PZ2 & PZ3
 ⊖ » SL4, SL5 & SL6mm
» 9 Pce 1/4" Sockets : 4, 5, 6, 7, 8, 9, 10, 11, 12mm
4 Pce Accessories
 » 1 x T-Handle Magnetic Bit Holder
 » 1 x 60mm Socket Adaptor
 » 1 x 25mm Adaptor
 » 1 x Soft Grip Ratchet Screwdriver



Precision Screwdriver Sets

Part No. KT2105
5 Pce Precision Electronic Insulated Screwdriver Set
2 Component Handles

Contents:
T6 x 65, T7 x 65, T8 x 65,
T9 x 65, T10 x 65mm

CrV
CHROME
VANADIUM



Part No. KT2106
6 Pce Precision Electronic Insulated Screwdriver Set
2 Component Handles

- ⊖ 2.0 x 65mm
- ⊖ 2.5 x 65mm
- ⊖ 3.0 x 65mm
- ⊕ PH000 x 65mm
- ⊕ PH00 x 65mm
- ⊕ PH0 x 65mm

CrV
CHROME
VANADIUM



Part No. KT2108
8 Pce Insulated Screwdriver & Tester Set
Contents : 7 Pce Insulated Screwdrivers
1 Pce 140mm Tester

- ⊖ 0.6 x 3.5 x 75mm
- ⊖ 0.8 x 4.0 x 100mm
- ⊖ 1.0 x 5.5 x 125mm
- ⊖ 1.2 x 6.5 x 150mm
- ⊕ PH0 x 75mm
- ⊕ PH1 x 80mm
- ⊕ PH2 x 100mm

CrV
CHROME
VANADIUM



Insulated for electrical work

Part No. KT2109
8 Pce Electrician Kit

- ⊖ 3.5 x 75mm, 4.0 x 100mm
- ⊕ PH0 x 75mm, PH2 x 100mm
- 1 x Tester 200 - 250V
- 1 x Diagonal cutting pliers
- 1 x Industrial long nose pliers
- 1 x Industrial combination pliers

CrV
CHROME
VANADIUM



Part No. KT2502
2 Pce Insulated VDE Screwdriver Set
Set consists of;
SL 3.5 x 75mm
PH 1 x 80mm

Precision Swivel Top Screwdriver Sets



Part No. KT2467

7 Pce Screwdriver Set
Set consists of;

- SL 1.5 x 50, 2 x 50mm
- PH 000 x 50, 00 x 50mm
- TX T6 x 50, T7 x 50, T8 x 50mm



Part No. KT2467-1

7 Pce Precision Screwdriver Set
(for cell phone use) - Set consists of;

- SL 1.5 x 50, 2 x 50mm
- PH 00 x 50mm
- Spanner M2.6
- TX T4 x 50, T5 x 50, T6 x 50mm



Part No. KT2468

14 Pce Screwdriver Set
Set consists of;

- SL 1.5 x 50, 2 x 50, 2.5 x 50, 3 x 50mm
- PH 000 x 50, 00 x 50, 0 x 50, 1 x 50mm
- TX T5 x 50, T6 x 50, T7 x 50, T8 x 50, T9 x 50, T10 x 50mm

Precision Screwdriver Sets



Part No. KT4001

4-in-1 Pocket Precision Screwdriver
 • in Counter-top Display Box
 • 48 per box (Sold as a box of 48)

Part No. KT4001-1

1 Pce 4-in-1 Pocket Precision Screwdriver
 • Ends : PH0 x 1/8", 5/32" x PH1
 • Satin finish, heat treated bits
 • Easy to carry pen size with clip

Part No. KT4001-2
1 Pce 4-in-1 Pocket Precision Screwdriver Carded

• Ends : PH0 x 1/8", 5/32" x PH1
 • Satin finish, heat treated bits
 • Easy to carry pen size with clip



Precision Tools

Part No. TC4403

2-in-1 Magnetize & Demagnetize Tool

Material: Magnet, plastic

Purpose: For magnetizing and demagnetizing different tools

Simple & easy to use small device

Instructions for Use:

- » To magnetize a tool, insert the tool into the hole labelled "Magnetize"
- » To demagnetize a tool, insert the tool into the hole labelled "Demagnetize"



Part No. TC4404

Offset Tweezers

» Point Style - Sharp Bent

» Quality tweezer for electronics, radios and other small or miniature assembly, servicing and repairs



Part No. TC4409

Pin Vise Swivel Head MINI

- » Soft touch handle
- » Brass body
- » Chuck storage inside handle



Part No. TC4407

4 Pce Precision Probe Set

- » For probing, cleaning, picking or marking small work surfaces
- » Set includes the most popular mini-tool configurations: Straight 180°, Hook 35° & 2 x Bend 90°



TCPH001

4 Pce Pick Hook Set

- Engineered for industrial, automotive, hobby & craft use
- Can be used for a variety of pulling and marking applications

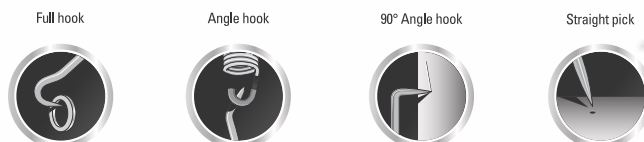

Gun Repair & Maintenance Set



CrV
CHROME
VANADIUM

Part No. KT2789

89 Pce Gun Repair & Maintenance
Screwdriver Set

Set Includes;

- » 54 Hollow-ground Flat Bits
- » 15 Speciality Gunsmith Bits
- » 8 Allen Bits
- » 4 Phillips Bits
- » 3 Torx Bits
- » Square to Hex Adaptor
- » 3" Shaft Extension
- » Regular Length No-Slip Handle
- » Short Length No-Slip Handle
- » Handy Carry Case
- » Bit Location Guide

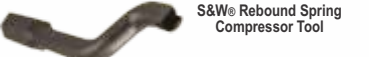

The bits are designed to fit gun screw slots correctly to prevent damage



Correct fit with hollow ground flat bits



Incorrect fit with standard screwdriver bits



Plus



Allen Key Sets



Part No. NT2114
13 Pce Metric HEX
Wrench System
» Bonus Torque Handle
w/Flip lock holder



Part No. NT2115
18 Pce Combo HEX Key Set
» Chrome Vanadium Steel for
maximum performance



Part No. NT2116
8 Pce TORX T-Handle
Wrench Set
» Sizes : T10, T15, T20,
T25, T30, T40, T45, T50

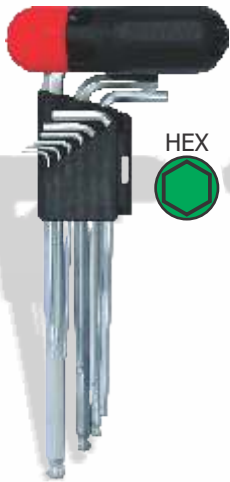

Part No. NT2125
9 Pce Ball Point
Allen Key Set
w/Interchangeable Handle

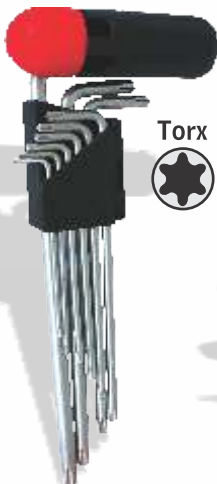

Part No. NT2126
9 Pce Torx Allen Key Set
w/Interchangeable Handle
Sizes : T10 - T50



Part No. NT2636
8 Pce Ball Point
Allen Key Set with non-slip
Rubber T-Handles

Part No.	Description
NT2636-2	Ball Point T-handle Hex Allen Key 2.0mm
NT2636-25	Ball Point T-handle Hex Allen Key 2.5mm
NT2636-3	Ball Point T-handle Hex Allen Key 3.0mm
NT2636-4	Ball Point T-handle Hex Allen Key 4.0mm
NT2636-5	Ball Point T-handle Hex Allen Key 5.0mm
NT2636-6	Ball Point T-handle Hex Allen Key 6.0mm
NT2636-8	Ball Point T-handle Hex Allen Key 8.0mm
NT2636-10	Ball Point T-handle Hex Allen Key 10.0mm



Part No. NT2137
Hex Key Set 10 Pc
1.5 - 10mm Carded
CR-V - Short



Part No. NT2106
Hex Key Set 9 Pc
Ball Point 1.5 - 10mm
CR-V - Long



Part No. NT2111
Hex Key Set 10 Pc
Ball Point 1.5 - 10mm
CR-V Long



Part No. NT2116-1
Torx Key Set 10 Pc
T9 - T50 CR-V



Part No. NT2116-2
Torx Security Key Set 10 Pc
T9 - T50 CR-V

Allen Key Sets

Part No. Description

NT2261	Folding Key set HEX 2, 2.5, 3, 4, 5, 6 Red Chrome Plated
NT2262	Folding Key Set Ball Point 2, 2.5, 3, 4, 5, 6 Yellow Chrome Plated
NT2263	Folding Key Set TORX T8, 9, 10, 15, 20, 25, 30 Purple Chrome Plated



NT2262



NT2263



NT2261

Part No. NT2112
12 Pce Folding Socket & Screwdriver Set
» Ideal for working on bicycles



Part No. NT2304
10 Pce Hex Allen Key Set on Key Ring
Sizes: 1.5, 2, 2.5, 3, 4, 5, 5.5, 6, 8, 10mm



Part No. NT2507
30 Pce Ball Point Allen Key Set
Metric & Imperial Sizes in Storage case



Part No. NT2508
9 Pce 1.5 - 10mm CR-V Short

ALLEN KEYS LOOSE

Part No.	Size
TCAK10015	1.5mm
TCAK10020	2mm
TCAK10025	2.5mm
TCAK10030	3mm
TCAK10040	4mm
TCAK10050	5mm
TCAK10055	5.5mm
TCAK10060	6mm
TCAK10070	7mm
TCAK10080	8mm
TCAK10090	9mm
TCAK10100	10mm
TCAK10120	12mm



Part No. NT0569
MINI Folding Aluminium HEX Allen Key Sets
6-in-1 Professional
Metric : 2, 2.5, 3, 4, 5, 6mm
TORX : T9, T10, T15, T20, T25, T27
Screwdriver : PH00, PH0, PH1, SL3, SL4, SI5
» **30 per Jar** (Sold as a Jar of 30)



Ideal for;

- » Automotive market
- » Aircrafts, boat and ship repairs
- » All riveting applications
- » Replaces hand riveting
- » General facility maintenance and repairs
- » Roofing and fencing

Turn your drill into an efficient Nut or Pop riveter

Drill Riveters



Drill not included

**TCRIV001
Drill Pop Riveter**

- Maximum Stroke : 18mm
- Nosepieces included : 4 (2.4, 3.2, 4.0 & 4.8mm)
- Shank : 1/4" (6.35mm)
- Weight (grams) : 500
- Recommended RPM : Low speed < 600RPM
- » Can be used on aluminium, steel & stainless steel
- » 1/4" Hex shank (6.35mm) to fit 3 Jaw Chucks & most electric & cordless drills & drivers
- » Instruction manual included
- » Spare parts available

Nut Riveters



Drill not included

**TCRIV002
Drill Nut Riveter**

- Maximum Stroke : 18mm
- Nose pieces included : 4 (M3, M4, M5 & M6)
- Thread Mandrels : 4
- Shank : 1/4" (6.35mm)
- Weight (grams) : 580
- Recommended RPM : Low speed < 240RPM
- » Can be used on aluminium, steel & stainless steel
- » 1/4" Hex shank (6.35mm) to fit 3 Jaw Chucks & most electric & cordless drills & drivers
- » Instruction manual included
- » Spare parts available

Riveting Capability	Rivet Nut Size		2.4 mm (3/32")	3.2 mm (1/8")	4.0 mm (5/32")	4.8 mm (3/16")
	Blind Rivet	Material	✓	✓	✓	✓
		Aluminum	✓	✓	✓	✓
		Steel	✓	✓	✓	✓
		Stainless Steel	✓	✓	✓	✓

Riveting Capability	Rivet Nut Size		M3	M4	M5	M6
	Nut Material	Material	✓	✓	✓	✓
		Aluminum	✓	✓	✓	✓
		Steel	✓	✓	✓	✓
		Stainless Steel	✓	✓	✓	✓

Hand Riveter

**TCRG0300
Aluminium Riveter
2 Jaw design**

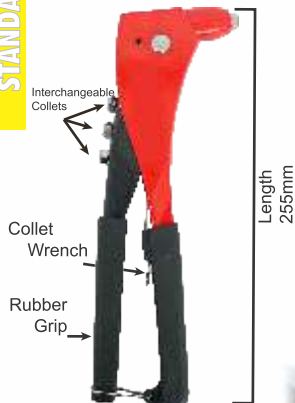

- Rivet Capacity;**
2.4, 3.2, 4.0 & 4.8mm
- » Rubber grip for comfort
 - » High grade aluminium die cast housing with carbon steel forged & heat-treated handle
 - » For aluminium, steel & stainless steel rivets



**TCRG0310
Aluminium Riveter
3 Jaw Design for maximum rivet grip**

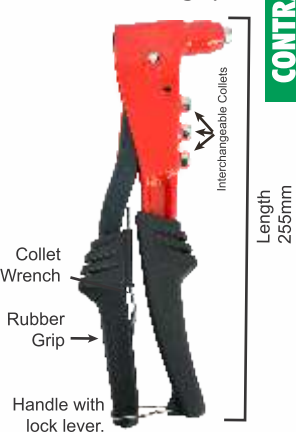

CONTRACTOR

**TCRG0320
3 Jaw Lazy Tong Hand Riveter
3 Jaw design for industrial use**

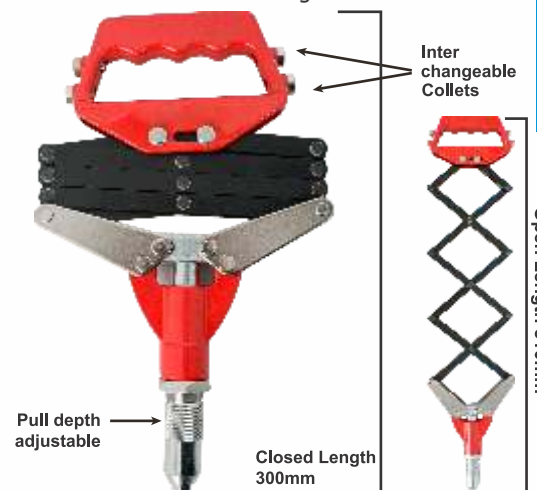

INDUSTRIAL

- Rivet Capacity; 3.2, 4.0, 4.8, 6.0 & 6.4mm
- » Slim design for hard to reach riveting application
 - » Lattice levering system reduces operator fatigue
 - » For aluminium, steel & stainless steel rivets

Cutting & Grinding Discs

Very thin discs enable you to achieve a clean cut in the shortest time using a minimum amount of force
10 per pack Shrinkwrapped / Order in packs of 10

STEEL & STAINLESS STEEL

Size	Part No.	INDUSTRIAL
115 x 1.0 x 22.2mm	ABR115S-2	
115 x 0.8 x 22.2mm	ABR115S-5	
115 x 1.0 x 22.2mm	ABR115S-6	
115 x 1.6 x 22.2mm	ABR115S-7	
115 x 3.0 x 22.2mm	ABR115S-8	
115 x 2.5 x 22.2mm	ABR115S-9	
230 x 2.0 x 22.2mm	ABR230S-5	
230 x 3.0 x 22.2mm	ABR230S-6	
230 x 2.5 x 22.2mm	ABR230S-7	

STEEL

Size	Part No.	INDUSTRIAL
76 x 1.1 x 9.53mm	ABR07600	
For 76mm Airtool grinder		
115 x 1.6 x 22.2mm	ABR115S-1	
115 x 0.8 x 22.2mm	ABR115S-3	
115 x 3.0 x 22.2mm	ABR115S-4	
115 x 1.0 x 22.2mm	ABR115SE	
115 x 1.0 x 22.2mm	ABR115S-10	
180 x 2.5 x 22.2mm	ABR180S	
230 x 2.0 x 22.2mm	ABR230S-1	
230 x 1.6 x 22.2mm	ABR230S-2	
230 x 3.0 x 22.2mm	ABR230S-3	
230 x 1.8 x 22.2mm	ABR230S-8	
230 x 2.5 x 22.2mm	ABR230S-9	
230 x 3.0 x 22.2mm	ABR230S-10	
300 x 3.0 x 25.4mm	ABR300S	
350 x 3.0 x 25.4mm	ABR350S	
400 x 3.0 x 25.4mm	ABR400S	

MASONRY

Size	Part No.	INDUSTRIAL
115 x 1.6 x 22.2mm	ABR115M-1	
115 x 1.0 x 22.2mm	ABR115M-2	
115 x 3.0 x 22.2mm	ABR115M-3	
115 x 2.5 x 22.2mm	ABR115M-4	
115 x 2.0 x 22.2mm	ABR115M-5	
125 x 2.5 x 22.2mm	ABR125M-1	
125 x 1.2 x 22.2mm	ABR125S-1	
125 x 1.6 x 22.2mm	ABR125S-2	
230 x 2.0 x 22.2mm	ABR230M-1	
230 x 3.0 x 22.2mm	ABR230M-2	
230 x 2.5 x 22.2mm	ABR230M-3	



GRINDING WHEEL - STEEL

Size	Part No.	INDUSTRIAL
76 x 4.8 x 9.53mm	ABRG07601	
For 76mm Airtool grinder		
115 x 6.0 x 22.2mm	ABRG115-1	
115 x 8.0 x 22.2mm	ABRG115-2	
125 x 6.0 x 22.2mm	ABRG125-1	
180 x 8.0 x 22.2mm	ABRG180	
230 x 6.0 x 22.2mm	ABRG230	



MULTI-PURPOSE CUTTING DISC

Size	Part No.	INDUSTRIAL
115 x 1.0 x 22.2mm	ABR115SM	
230 x 2.0 x 22.2mm	ABR230SM	
For steel, stainless steel, PVA and masonry (stone)		



Sold as a box of 50

STAINLESS STEEL

Size	Part No.	INDUSTRIAL
115 x 1.0 x 22.2mm	ABR115SS-1	
115 x 1.6 x 22.2mm	ABR115SS-2	
115 x 3.0 x 22.2mm	ABR115SS-3	
115 x 2.5 x 22.2mm	ABR115SS-4	
115 x 2.5 x 22.2mm	ABR115S-11	
115 x 3.0 x 22.2mm	ABR115S-12	
230 x 2.5 x 22.2mm	ABR230SS-3	



COMBOS

Part No.	Contents
COMBO 100	15 + 5 Free Cutting Discs Steel 115 x 1.0 x 22.23mm
COMBO 103	5 + 1 Free Cutting Discs Steel 115 x 1.0 x 22.23mm
COMBO 105	4 + 1 Free Cutting Discs Steel 230 x 1.6 x 22.23mm
COMBO 109	5 + 1 Free Cutting Discs Masonry 115 x 1.0 x 22.23mm
COMBO 110	10 Pce Cutting Discs in Tin Case 115 x 1.0 x 22.2mm
COMBO 113	5 + 1 Cutting Discs Steel 230 x 3.0 x 22.23mm
COMBO 115	10 + 5 Cutting Discs Steel & SS 115 x 1.0 x 22.2mm
COMBO 116	3 + 1 Free Cutting Discs Steel/SS 230 x 2.0 x 22.23mm + B5161 Safety Glasses
COMBO 119	3 + 1 Free Cutting Discs Steel/SS 115 x 0.8 x 22.23mm
COMBO 160	5 + 1 Free Cutting Discs Steel 230 x 1.8 x 22.2mm
COMBO 162	50 + 5 Free Cutting Discs Steel 115 x 1.0 x 22.2mm

INDUSTRIAL

COMBO 160



COMBO 162



2-in-1 CUTTING & GRINDING STEEL

Size	Part No.	INDUSTRIAL
115mm x 2.8 x 22.2mm	ABR115GC	



COMBO 103



COMBO 110

Contractor Value Bulk Packs

ABR115S-2-10P : 10 Pack
Steel & SS 115 x 1.0 x 22.2mm

ABR115S-2-25P : 25 Pack
Steel & SS 115 x 1.0 x 22.2mm

Fibre Discs (with centre hole 22mm)

10 per pack Shrinkwrapped
Order in packs of 10

115mm			180mm			INDUSTRIAL			
Part No.	Grits	Pack	Part No.	Pack	Part No.		Pack		
ABR51016	16	5/pk	ABR55016	Bulk	ABR54016	16	5/pk	ABR56016	Bulk
ABR51024	24	5/pk	ABR55024	Bulk	ABR54024	24	5/pk	ABR56024	Bulk
ABR51036	36	5/pk	ABR55036	Bulk	ABR54036	36	5/pk	ABR56036	Bulk
ABR51060	60	5/pk	ABR55060	Bulk	ABR54060	60	5/pk	ABR56060	Bulk
ABR51080	80	5/pk	ABR55080	Bulk	ABR54080	80	5/pk	ABR56080	Bulk
ABR51100	100	5/pk	ABR55100	Bulk	ABR54100	100	5/pk	ABR56100	Bulk



Use on backing pad
with angle grinder
Recommended pads;
» TCBP115-1
» TCBP115-2 : 60 - 100 Grit
» TCBP115-3 : 16 - 36 Grit

Vulcanized Fibre Discs

115mm			180mm			INDUSTRIAL
Part No.	Grits	Pack Size	Part No.	Grits	Pack Size	
ABR72016	16	Bulk	ABR75016	16	Bulk	
ABR72024	24	Bulk	ABR75024	24	Bulk	
ABR72036	36	Bulk	ABR75036	36	Bulk	
ABR72060	60	Bulk	ABR75060	60	Bulk	

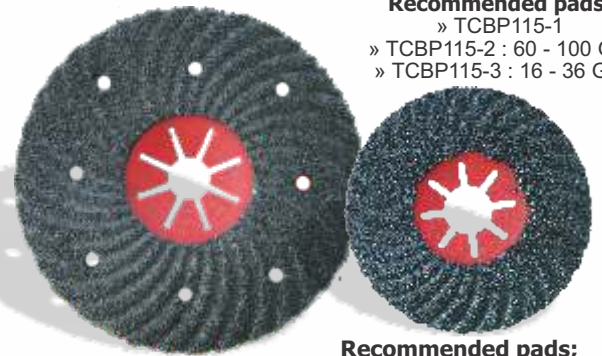

Recommended pads;
» TCBP115-3
» TCBP178-1

Application/Material

- » Ideal for grinding marbelite surfaces in swimming pools
- » Also suitable to grind concrete surfaces and for heavy duty sanding
- » Also used for rubber vulcanising
- » For use on an angle grinder
- » It is recommended for use with a TCBP backing pad

Flap Sanding Discs

FLAT 15°

FLAP SANDING DISCS

Part No.	Grits	Angle	INDUSTRIAL
TCFD115-2-40	40	15°	
TCFD115-2-60	60	15°	
TCFD115-2-80	80	15°	
TCFD115-2-120	120	15°	
TCFD115-40	40	Flat	
TCFD115-60	60	Flat	
TCFD115-80	80	Flat	
TCFD115-120	120	Flat	
TCFD180-2-40	40	15°	
TCFD180-2-80	80	15°	
TCFD230-40	40	Flat	
TCFD230-60	60	Flat	
TCFD230-80	80	Flat	
TCFD230-120	120	Flat	



» Use on wood & mild steels
» Use on angle grinder

ZIRCONIUM FLAP SANDING DISCS

Part No.	Grits	Angle	INDUSTRIAL
TCFD115-3-40	40	Flat	
TCFD115-3-60	60	Flat	
TCFD115-3-80	80	Flat	
TCFD115-3-120	120	Flat	
TCFD115-4-40	40	15°	
TCFD115-4-60	60	15°	
TCFD115-4-80	80	15°	
TCFD180-4-40	40	15°	
TCFD180-4-60	60	15°	
TCFD180-4-80	80	15°	

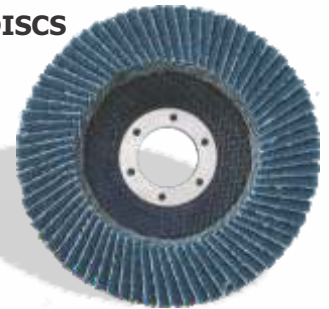

» Use on stainless steel
» Use on angle grinder

ROUND EDGE

Part No.	Grits	Angle	INDUSTRIAL
TCFD115-3-40R	40	Flat	
TCFD115-3-60R	60	Flat	
TCFD115-3-80R	80	Flat	
TCFD115-3-120R	120	Flat	



ZIRCONIUM FLAP SANDING DISC COMBOS

Part No.	Grits	Angle	115mm	INDUSTRIAL
COMBO200	40	Flat	Flap Discs 4 + 1 FREE	
COMBO201	60	Flat	Flap Discs 4 + 1 FREE	
COMBO202	80	Flat	Flap Discs 4 + 1 FREE	
COMBO203	120	Flat	Flap Discs 4 + 1 FREE	



For normal grinding applications as well as
fillet welding & corner grinding applications
» Use on angle grinder
» Use on stainless steel & steel, non-ferrous
metals, laquers & wood

ALUMINIUM OXIDE FLAP SANDING DISC COMBOS

Part No.	Grits	Angle	115mm	INDUSTRIAL
COMBO300	40	Flat	12 Pce in Metal Tin	
COMBO301	60	Flat	12 Pce in Metal Tin	
COMBO302	80	Flat	12 Pce in Metal Tin	
COMBO303	120	Flat	12 Pce in Metal Tin	



Non-woven Flap Disc

Part No.	Size	Colour	Type	INDUSTRIAL
TCNW115-1	115 x 22mm	Yellow	Coarse	
TCNW115-2	115 x 22mm	Red	Medium	
TCNW115-3	115 x 22mm	Blue	Fine	
TCNW115-4	115 x 22mm	Grey	Extra Fine	

- » De-scaling
- » Rust cleaning
- » Paint surface treatment
- » Stainless steel polishing
- » Weld seam polishing
- » Wood polishing





Wire Brushes

* All in Blister Pack except Bulk codes

- Hardened steel wire

- Brass coated for longer life & rust resistant
- Ideal for removing rust, paint, dirt and scale

WIRE WHEEL BRUSH

Part No.	Size
TCWW3806	38mm x 6mm with shaft
TCWW5006	50mm x 6mm with shaft
TCWW6306	63mm x 6mm with shaft
TCWW7506	75mm x 6mm with shaft
TCWW10006	100mm x 6mm with shaft



STEEL WIRE CUP BRUSH

Part No.	Size
TCW CR6014-2	60mm x M14 Crimped
TCW CR7514-2	75mm x M14 Crimped
TCW CR10014-2	100mm x M14 Crimped
TCW CR12514-2	125mm x M14 Crimped
TCW CR15014-2	150mm x M14 Crimped



WIRE END BRUSH

Part No.	Size
TCWE1206	12mm x 6mm with shaft
TCWE2406	24mm x 6mm with shaft
TCWE2406HS	30mm x 6mm with shaft
TCWE3006	30mm x 6mm with shaft



SINGLE SECTION WIRE WHEEL BRUSH

Part No.	Size
TCWS115-1	115 x M14 Plain Twisted
TCWS115-2	115 x M14 Stinger Twisted
TCWS175-1	175 x M14 Plain Twisted
TCWS175-2	175mm x M14 Twisted



WIRE CUP BRUSH

Part No.	Size
TCWC5006	50mm x 6mm with shaft
TCWC6306	63mm x 6mm with shaft
TCWC6506	65mm x 6mm with shaft
TCWC7506	75mm x 6mm with shaft
TCWC8006	80mm x 6mm with shaft



WIRE SPIRAL BRUSH

Part No.	Size
TCW SP285590	90mm x 60mm x 28mm



WIRE WHEEL FOR BENCHGRINDER

Part No.	Size
TCW150	150 x 25mm
TCW150-2	150 x 25mm 0.30mm Wire
TCW200	200 x 25mm



STEEL WIRE WHEEL BRUSH

Part No.	Size
TCW SS150	150 x 25mm
TCW SS6306	63 x 6mm Shaft
TCW SS10006	100 x 6mm Shaft



TWISTED STEEL WIRE CUP BRUSH

Blister Pack	Bulk	Size
TCW TW6514	TCW TW6514B	65mm x M14
TCW TW8014	TCW TW8014B	80mm x M14
TCW TW10014	TCW TW10014B	100mm x M14
TCW TW12014	TCW TW12014B	120mm x M14
TCW TW15014	TCW TW15014B	150mm x M14

STEEL WIRE WHEEL BRUSH

Part No.	Size
TCWB115-1	115mm x M14 Crimped Bevel
TCWB115-2	115 x M14 Twisted Bevel
TCWB115-2B	115 x M14 Twisted Bevel Bulk



TWISTED STEEL WIRE CUP BRUSH HEAVY DUTY

TCW TW12014HD	TCW TW12014HD-B	125mm x M14 with 0.8mm Wire
TCW TW15014HD	TCW TW15014HD-B	150mm x M14 with 0.8mm Wire
TCW TW12014HS		125mm x M14 High Speed

NYLON CUP BRUSH

Part No.	Size
TCNY0806	0.2 x 80mm x 6mm Black



NYLON WHEEL BRUSH

Part No.	Size
TCNY05006	50mm x 6mm shaft Crimped
TCNY07506	75mm x 6mm shaft Crimped
TCNY10006	100mm x 6mm shaft Crimped



STAINLESS STEEL WIRE CUP BRUSH

Part No.	Size
TCSS07514	75mm x M14 Crimped
TCSS10014	100mm x M14 Crimped
TCSS15014	150mm x M14 Crimped
TCSS06514	65mm x M14 Twisted
TCSS08014	80mm x M14 Twisted
TCSS10014-2	100mm x M14 Twisted
TCSS12514	125mm x M14 Twisted
TCSS10014-2B	100mm x M14 Crimped Plain
TCSS10014B	100mm x M14 Crimped Bulk
TCSS15014B	150mm x M14 Crimped Bulk

PIPE CLEANER & DEBURRER TUBE BRUSH

Pipe Cleaner & Deburrer Tube Brush
15 & 19mm Wire Brush
PART NO. TCWPC001

STEEL WIRE CUP BRUSH / BRASS COATED

Blister Pack	Bulk	Bulk Plain	Size
TCW CR6014	TCW CR6014B	TCW CR6014-2B	60mm x M14 Crimped
TCW CR7514	TCW CR7514B	TCW CR7514-2B	75mm x M14 Crimped
TCW CR10014	TCW CR10014B	TCW CR10014-2B	100mm x M14 Crimped
TCW CR12514	TCW CR12514B	TCW CR12514-2B	125mm x M14 Crimped
TCW CR15014	TCW CR15014B	TCW CR15014-2B	150mm x M14 Crimped

STEEL WIRE CUP BRUSH

NON SPARKING (Bulk)

Blister Pack	Bulk	Size
TCW CRNS6014B	60mm x M14 Crimped	
TCW CRNS7514B	75mm x M14 Crimped	
TCW CRNS10014B	65mm x M14 Crimped	



Wire Brush Sets



3 Pce Wire Brush Set
Shaft mounted circular cup
& end brushes
PART NO. TCW003-1



3 Pce Wire Brush Set
Circular brushes with
separate shaft
PART NO. TCW003-2



4 Pce Wire Brush Set
Shaft mounted circular cup
and end brushes
PART NO. TCW004-1



4 Pce Wire Brush Set
Shaft mounted circular cup,
end brushes & scratch brushes
PART NO. TCW004-2



5 Pce Wire Brush Set
Shaft mounted circular cup
& end brushes
PART NO. TCW005-1



10 Pce Wire Brush Polishing Set
PART NO. TCW010



3 Pce Bench Grinder
Wire Brush Set 150mm
Wire, Nylon & Buff
PART NO. TCW003-3



3 Pce Wire Brush Set
Twist knot wheel 100mm,
Cup & Crimped Wheel for Angle Grinder
PART NO. TCW003-4



2 Pce Wire Cup Brush Set
75mm X M14
Crimped & Knotted
For 115mm Angle Grinders
PART NO. TCW006-2



5 Pce Wire Brush Angle Grinder Kit
M14 Crimped & Knotted
Hand Brush
PART NO. TCW006-3

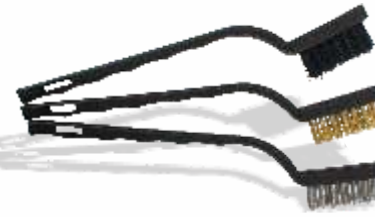

3 Pce Mini Wire Brush Set
Brass/Stainless Steel/Nylon
PART NO. BR013



9 Pce Brass Tube
Pipe Brush Set
Part No. TCW006-8



5 Pce Mini Brass Wire Brushes
3.2mm Shaft Assorted Shapes
PART NO. TCW006-5

9 Pce Nylon Tube
Pipe Brush Set
**PART NO.
TCW006-7**



5 Pce Mini Wire Brushes
Nylon 3.2mm Shaft
Assorted Shapes
PART NO. TCW006-6



5 Pce Wire Brushes Mini
Stainless Steel
3.2mm Shaft Assorted Shapes
Part No. TCW006-4

#	Brush Dia	Brush Length	Handle Length
1	8	75	100
2	19 - 43	105	60
3	32	157	90
4	28	98/70	100
5	13	100	130
6	17	98	190
7	7	74	205
8	19	93	200
9	8	112	175

Hand Wire Brushes



Wire Hand Brush
Order 24 for a box
TCW17230-1



TCW17230-2
Wire Hand Brush
Stainless Steel for long brush life
Multi-purpose use

TCW17230-3
Wire Hand Brush
Brass for long brush life
For medium duty cleaning
Minimal surface damage

TCW17230-4
Wire Hand Brush
Nylon bristles for delicate applications
Light duty cleaning - scratch free
Multi-purpose use

Wire Hand Brush - Scratch
Wooden Handle
PART NO. TCW HB01



Wire Hand Brush - Block
Wooden - Rectangular
PART NO. TCW HB02



Paint/Can Opener



Paint & Can & Bottle Opener
All Steel
PART NO. BR010

Wire Brushes - Braai/BBQ

Wire Brush
450mm Handle 18"
For cleaning braai grids
PART NO. BR001



Three sided Wire Brush
530mm Handle 21"
For cleaning braai grids
PART NO. BR002



Razor Scraper Jar



MINI Razor Scraper Set
60/Candy Jar
5 Assorted colours
PART NO. BR008

Replacement Blades
100Pcs Single edge
Stainless Steel
Fits TorkCraft BR008
Plus most mini scrapers
PART NO. BR012



Stripper Brushes

Soft Grip Wide Nylon
Stripper Brush
5 x 11 Row
PART NO. BR003



Soft Grip Wide Brass
Stripper Brush
5 x 11 Row
PART NO. BR004



Soft Grip Wide
Stainless Steel
Stripper Brush
5 x 11 Row
PART NO. BR005



3 Pce Soft Grip
Wide Brush Set
Stainless Steel,
Brass, Nylon
5 x 11 Row (in blister)
PART NO. BR006



15-in-1 Multi-Purpose Scraper Tool



15-in-1 Multi-Purpose Tool 2½" (6.4cm)
PART NO. BR007

- » Paint can opener
- » Bottle opener
- » Crack cleaner
- » Spackle knife
- » Nail setter
- » Rasp tool
- » ¼" wrench
- » ⅜" wrench
- » Flat screwdriver
- » Paint scraper
- » Compound spreader
- » Radius scraper
- » Utility cutter
- » Roller cleaner
- » Nail puller
- » Window putty tool

Putty Knives



3 Pce Putty Knife Set Plastic
Sizes : 38, 76 & 100mm
PART NO. BR009

Grinding Wheels



Part No.	Grit / Type / Colour	RPM	INDUSTRIAL	
FOR ANGLE GRINDER 100 x 50mm x M14				
TCGR100-1	#36 Bowl	9500		
TCGR100-2	#36 Cup	9500		
FOR ANGLE GRINDER 110 x 58mm x M22				
TCGR110-1	#36 Bowl	8500		
FOR BENCH GRINDER 150 x 20 x 32mm (with bushes)				
TCGR150-7	36 Fine BLACK	4136		
TCGR150-8	36 Fine GREEN	4136		
TCGR150-9	36 Fine WHITE	4136		
TCGR150-10	60 Fine BLACK	4136		
TCGR150-11	60 Fine GREEN	4136		
TCGR150-12	60 Fine WHITE	4136		
FOR BENCH GRINDER 150 x 25 x 32mm (with bushes)				
TCGR150-1	60 Fine GREY	4136		
TCGR150-2	36 Coarse GREY	4136		
TCGR150-3	36 Coarse GREEN	4136		
TCGR150-4	60 Fine GREEN	4136		
TCGR150-5	36 Coarse WHITE	4136		
TCGR150-6	36 Coarse WHITE	4136		
FOR BENCH GRINDER 200 x 25 x 32mm (with bushes)				
TCGR200-1	60 Fine GREY	3170		
TCGR200-2	36 Coarse GREY	3170		
TCGR200-3	36 Coarse GREEN	3170		
TCGR200-4	60 Fine GREEN	3170		
TCGR200-5	36 Coarse WHITE	3170		
TCGR200-6	60 Fine WHITE	3170		
TCGWD001	Grinding Wheel Dresser			

Economic & efficient in grinding of all steels
All Bench Grinder Wheels come with 4 different size bushes;
1", 3/4", 5/8" & 1/2".



Aluminium Oxide Wheels (BLACK & GREY) are used for grinding all metals in a variety of grinding operations ranging from rough sharpening to off-hand grinding or sharpening of tools.

Silicone Carbide Wheels (GREEN) are suitable for grinding hard alloy, optical glass, vitrify, gem, agate, honing cylinder sleeve and other hard friable materials.

Fused Aluminium Wheels (WHITE) are suitable for work pieces of strong intensity such as chilled steel, high-speed steel, high-carbon steel for high hardness grinding.

Emery Cloth

	Per Roll	Per Roll	Grits		Per Roll	Per Roll	Grits	INDUSTRIAL		
25mm x 50M	ABR01040	25mm x 10M	ABR01040-10	40	50mm x 50M	ABR02040	50mm x 10M		ABR02040-10	40
	ABR01060		ABR01060-10	60		ABR02060			ABR02060-10	60
	ABR01080		ABR01080-10	80		ABR02080			ABR02080-10	80
	ABR01100		ABR01100-10	100		ABR02100			ABR02100-10	100
ABR01120	ABR01120-10	120	ABR02120	ABR02120-10	120					
ABR01180	ABR01180-10	180	ABR02150							
ABR01240	ABR01240-10	240	ABR02180	ABR02180-10	180					
ABR01400	ABR01400-10	400	ABR02240	ABR02240-10	240					
				ABR02400	ABR02400-10	400				

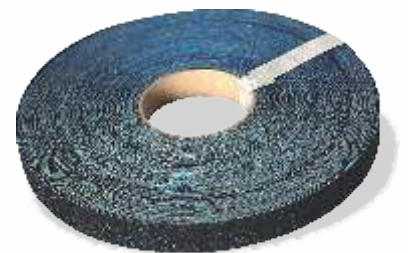

Production Paper

Part No.	Size
ABR105036	70mm X 50m
ABR105060	70mm x 50m
ABR105080	70mm x 50m
ABR105120	70mm x 50m



Sanding Belt Cleaner

Part No. T BC32324

Sanding Belt Cleaner (carded) - Dimensions : 105 x 40 x 35mm

Application/Material

- Removes embedded particles with the ease of an eraser

Features/Benefits

- Extends sanding belts, discs and drum life up to 10 times

- Cleans while sander is running

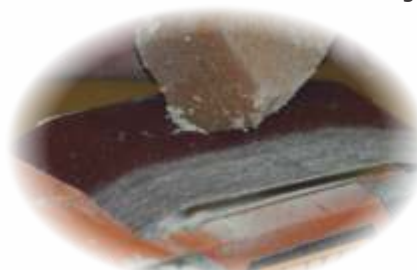

Sanding Belts

60 x 400mm			
2 Pack	10 Pack	Type	Grits
ABR03040	ABR03040-10	Coarse	40
ABR03060	ABR03060-10	Coarse	60
ABR03080	ABR03080-10	Medium	80
ABR03100	ABR03100-10	Medium	100
ABR03120	ABR03120-10	Fine	120
ABR03150		Fine	150
ABR03180		Fine	180
ABR03240		X-Fine	240
ABR03320		X-Fine	320

64 x 406	64 x 406mm	Type	Grits
ABR04040	ABR04040-10	Coarse	40
ABR04060	ABR04060-10	Coarse	60
ABR04080	ABR04080-10	Medium	80
ABR04100		Medium	100
ABR04120	ABR04120-10	Fine	120
ABR04150		Fine	150
ABR04180		Fine	180
ABR04240		Xtra Fine	240
ABR04320		Xtra Fine	320

100 x 530mm			
ABR14040	ABR14040-10	Coarse	40
ABR14060	ABR14060-10	Coarse	60
ABR14080	ABR14080-10	Medium	80
ABR14100		Medium	100
ABR14120	ABR14120-10	Fine	120

100 x 915mm			
ABR20040	40	Bulk	
ABR20060	60	Bulk	
ABR20080	80	Bulk	
ABR20100	100	Bulk	
ABR20120	120	Bulk	

75 x 533mm (Zirconium)			
2 Pack	Type	Grits	
ABR13040	Coarse	40	
ABR13060	Coarse	60	
ABR13080	Medium	80	
ABR13100	Medium	100	
ABR13120	Fine	120	

75 x 457mm			
2 Pack	10 Pack	Type	Grits
ABR06040	ABR06040-10	Coarse	40
ABR06060	ABR06060-10	Coarse	60
ABR06080	ABR06080-10	Medium	80
ABR06100	ABR06100-10	Medium	100
ABR06120	ABR06120-10	Fine	120
ABR06180		Fine	180
ABR06220		X-Fine	220
ABR06240		X-Fine	240
ABR06400		X-Fine	400
ABR06600			600

75 x 510mm			
ABR07040	ABR07040-10	Coarse	40
ABR07060	ABR07060-10	Coarse	60
ABR07080	ABR07080-10	Medium	80
ABR07100		Medium	100
ABR07120	ABR07120-10	Fine	120

100 x 560mm			
ABR15040	ABR15040-10	Coarse	40
ABR15060	ABR15060-10	Coarse	60
ABR15080	ABR15080-10	Medium	80
ABR15100	ABR15100-10	Medium	100
ABR15120	ABR15120-10	Fine	120

150 x 1220mm			
ABR19040	40	Bulk	
ABR19060	60	Bulk	
ABR19080	80	Bulk	
ABR19100	100	Bulk	
ABR19120	120	Bulk	

100 x 610mm (Zirconium)			
2 Pack	Type	Grits	
ABR17040	Coarse	40	
ABR17060	Coarse	60	
ABR17080	Medium	80	
ABR17100	Medium	100	
ABR17120	Fine	120	

75 x 533mm			
2 Pack	10 Pack	Type	Grits
ABR09040	ABR09040-10	Coarse	40
ABR09060	ABR09060-10	Coarse	60
ABR09080	ABR09080-10	Medium	80
ABR09100	ABR09100-10	Medium	100
ABR09120	ABR09120-10	Fine	120
ABR09180		Fine	180
ABR09240		X-Fine	240
ABR09400		X-Fine	400
ABR09600		X-Fine	600

75 x 610mm			
ABR12040	ABR12040-10	Coarse	40
ABR12060	ABR12060-10	Coarse	60
ABR12080	ABR12080-10	Medium	80
ABR12100		Medium	100
ABR12120	ABR12120-10	Fine	120

100 x 610mm			
ABR18040	ABR18040-10	Coarse	40
ABR18060	ABR18060-10	Coarse	60
ABR18080	ABR18080-10	Medium	80
ABR18100	ABR18100-10	Medium	100
ABR18120	ABR18120-10	Fine	120
ABR18180		Fine	180
ABR18240		X-Fine	240
ABR18400		X-Fine	400
ABR18600		X-Fine	600

100 x 620mm	
ABR26040	Coarse
ABR26060	Coarse
ABR26080	Medium
ABR26100	Medium
ABR26120	Fine

25 x 762mm	
ABR28040	Coarse
ABR28060	Coarse
ABR28080	Medium
ABR28120	Fine
ABR26180	Fine

Application/Material

» Designed for sanding wood, metal, fiberglass, auto-body filler and plastic

Features/Benefits

- » Full-bonded resin abrasive lasts up to four times longer than glue-bonded belts
- » Extra-heavy cloth backing resists tearing & stretching during sanding
- » Stronger joints eliminate belt breakage

Application/Material : Zirconium

» For ferrous & non-ferrous metals, stainless steel, wood, plastics & glass

Powerfile Sanding Belts

6 x 451mm (5pk)	
Part No.	Grits
ABR90040	40
ABR90080	80
ABR90100	100
ABR90120	120

13 x 451mm (5pk)	
Part No.	Grits
ABR93040	40
ABR93080	80
ABR93100	100
ABR93120	120

13 x 457mm (5pk)	
Part No.	Grits
ABR91040	40
ABR91080	80
ABR91100	100
ABR91120	120

30 x 451mm (5pk)	
Part No.	Grits
ABR89040	40
ABR89060	60
ABR89080	80
ABR89100	100
ABR89120	120



Mini Palm Sander

Part No.	Description
TCMS001	Mini Palm Sander Cordless 12V 1.3AH
TCMS001-01	Replacement Dust Container for TCMS001
TCMS001-02	Replacement Stent for TCMS001
TCMS001-03	Replacement Switch Kit for TCMS001
TCMS001-04	Replacement Gear Kit for TCMS001
TCMS001-05	Replacement Backing Pad Kit for TCMS001
TCBP001	Fast Charger for 12V Li-ion 1.3AH & 1.5AH Battery Pack
TCBP001-1	12V Li-ion 1.3AH Spare Battery for TORKCRAFT Cordless Tools
TCBP001-2	12V Li-ion 1.5AH Spare Battery for TORKCRAFT Cordless Tools
ABR37060	Velcro Sanding Triangle 60 Grit 145 x 145 x 100mm for TCMS001
ABR37080	Velcro Sanding Triangle 80 Grit 145 x 145 x 100mm for TCMS001
ABR37120	Velcro Sanding Triangle 120 Grit 145 x 145 x 100mm for TCMS001
ABR37180	Velcro Sanding Triangle 180 Grit 145 x 145 x 100mm for TCMS001



Triangle Hook & Loop Backed

94 x 94 x 94mm with holes

Part No.	Description	Grits	Pk Size
ABR21060	Triangle Hook & Loop Disc	60	5/pk
ABR21080	Triangle Hook & Loop Disc	80	5/pk
ABR21120	Triangle Hook & Loop Disc	120	5/pk
ABR21240	Triangle Hook & Loop Disc	240	5/pk

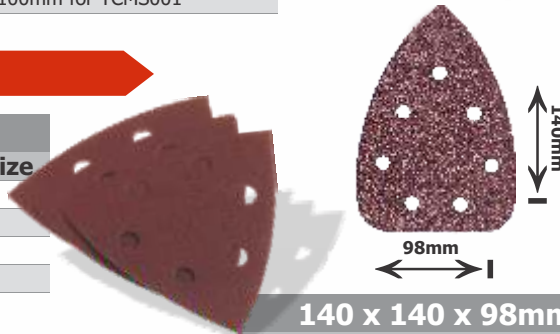

Use Hook & Loop Backing Pad with 7 holes / 140mm / 98mm wide

Part No.	Type	Grits
ABR22060	Medium	60
ABR22080	Medium	80
ABR22120	Fine	120
ABR22240	Extra Fine	240



140 x 140 x 98mm

Part No.	Description	Grits	Pk Size
ABR25040	Triangle Hook & Loop w/holes	40	5/pk
ABR25060	Triangle Hook & Loop w/holes	60	5/pk
ABR25080	Triangle Hook & Loop w/holes	80	5/pk
ABR25120	Triangle Hook & Loop w/holes	120	5/pk
ABR25180	Triangle Hook & Loop w/holes	180	5/pk
ABR25220	Triangle Hook & Loop w/holes	220	5/pk
ABR25400	Triangle Hook & Loop w/holes	400	5/pk
ABR25600	Triangle Hook & Loop w/holes	600	5/pk

Peel & Stick Discs (PSA)

10 Pack	Description	Grits	10 Pack	Description	Grits	10 Pack	Description	Grits
ABR39040	PSA No holes 125mm	40	ABR42040	PSA No holes 150mm	40	ABR40040	PSA No holes 304mm	40
ABR39060	PSA No holes 125mm	60	ABR42060	PSA No holes 150mm	60	ABR40060	PSA No holes 304mm	60
ABR39080	PSA No holes 125mm	80	ABR42080	PSA No holes 150mm	80	ABR40080	PSA No holes 304mm	80
ABR39120	PSA No holes 125mm	120	ABR42120	PSA No holes 150mm	120	ABR40100	PSA No holes 304mm	100
ABR39180	PSA No holes 125mm	180	ABR42180	PSA No holes 150mm	180	ABR40120	PSA No holes 304mm	120
ABR39240	PSA No holes 125mm	240	ABR42240	PSA No holes 150mm	240	ABR40180	PSA No holes 304mm	180

Application/Material

» Ideal for finishing wood, metal and fibreglass

Features/Benefits

- » Easy to use - just peel & stick aluminium oxide sanding discs
- » Eliminates messy glue or special screws
- » Premium, top-coated resin abrasive outlasts ordinary sandpaper



Hook & Loop Backed Discs

115mm - 10/Pk			125mm - 10/Pk			150mm - 10/Pk		
No hole	With hole	Grits	No hole	With hole	Grits	No hole	With hole	Grits
ABR24040	ABR30040	40	ABR27040	ABR33040	40	ABR35040	ABR36040	40
ABR24060	ABR30060	60	ABR27060	ABR33060	60	ABR35060	ABR36060	60
ABR24080	ABR30080	80	ABR27080	ABR33080	80	ABR35080	ABR36080	80
ABR24120	ABR30120	120	ABR27120	ABR33120	120	ABR35120	ABR36120	120
ABR24180	ABR30180	180	ABR27180	ABR33180	180	ABR35180	ABR36180	180
ABR24240	ABR30240	240	ABR27240	ABR33240	240	ABR35240	ABR36240	240
			ABR27060-1	BULK	60	ABR36320	ABR36400	320
						ABR36400	ABR36600	400
						ABR36600		600

Sanding Discs

125mm

Part No.	Grits	Description
ABR57080	80	Hook & Loop, no hole, Bulk
ABR57120	120	Hook & Loop, no hole, Bulk
ABR57180	180	Hook & Loop, no hole, Bulk
ABR60040	40	10/Pk with centre hole
ABR60080	80	10/Pk with centre hole
ABR60120	120	10/Pk with centre hole
ABR60240	240	10/Pk with centre hole

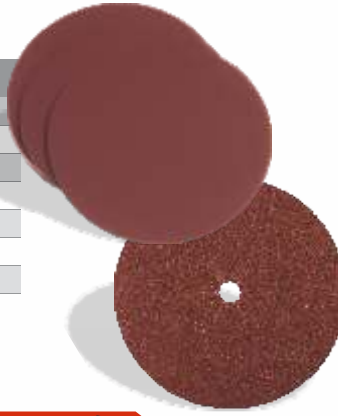

150mm

Part No.	Grits	Pk Size	Description
ABR63040	40	10/Pk	With centre hole
ABR63080	80	10/Pk	With centre hole
ABR63120	120	10/Pk	With centre hole
ABR63240	240	10/Pk	With centre hole

Use on backing pad with drilling machine
Recommended pads;

- » TCBP125C
- » TCBP150C
- » SPC00120 (Hook & Loop)

GOLD Abrasive Discs (Hook & Loop)

150mm w/Holes

50 Pack	Grits
ABR94040	40
ABR94060	60
ABR94080	80
ABR94100	100
ABR94120	120
ABR94150	150
ABR94180	180
ABR94220	220
ABR94240	240
ABR94320	320
ABR94400	400
ABR94500	500
ABR94600	600
ABR941500	1500
ABR942000	2000



Comes in a
Box of 50 Pcs

150mm No Holes

50 Pack	Grits
ABR95040	40
ABR95080	80
ABR95120	120
ABR95150	150
ABR95180	180
ABR95240	240
ABR95320	320
ABR95400	400
ABR95500	500



Comes in a
Box of 50 Pcs

INDUSTRIAL

Dura Mesh Abrasive Disc - Hook & Loop

150mm - For Sander Polisher

Part No.	Grits	Pk Size	Part No.	Grits	Pk Size
ABR58080	80	Bulk	ABR58080-03	80	3Pk
ABR58120	120	Bulk	ABR58120-03	120	3Pk
ABR58150	150	Bulk	ABR58150-03	150	3Pk
ABR58180	180	Bulk	ABR58180-03	180	3Pk
ABR58240	240	Bulk	ABR58240-03	240	3Pk
ABR58320	320	Bulk	ABR58320-03	320	3Pk
ABR58400	400	Bulk	ABR58400-03	400	3Pk
ABR58500	500	Bulk	ABR58500-03	500	3Pk

For ultimate dust extraction, reduced clogging

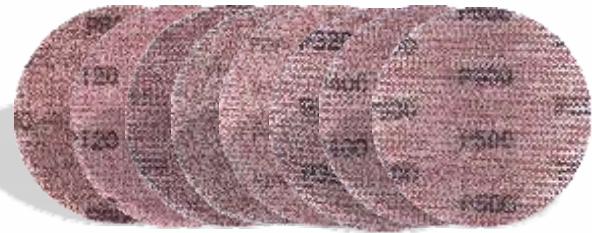

Sponge Sanding Block

Part No.	Size	Grit	Description	Qty
DURA SS01	100 x 70 x 25mm	80/120 Medium/Fine	Double-sided	1Pk
DURA SS02	120 x 90 x 25mm	60 Coarse	Single angle four-sided	1Pk
DURA SS03	120 x 75 x 25mm	80 Medium	Dual angle four-sided	1Pk
DURA SS04	125 x 100 x 10mm	100 Fine	Double-sided	2Pk

- » Black Aluminium Oxide sponge blocks allow for use on metal, plastic & wood
- » These washable grit sponges are ideal for dry or wet sanding
- » Sands into corners and round surfaces easily



Rotary Flap Sanders

Part No.	Description
TCRF4020-80	40 X 20mm 80 Grit
TCRF5020-80	50 x 20mm 80 Grit

Carded



Shank Size = 6mm

Part No.	Description	Carded
TCRF4020-120	40 x 20 x 6mm	120 Grit
TCRF4020-180	40 x 20 x 6mm	180 Grit
TCRF4020-220	40 x 20 x 6mm	220 Grit
TCRF6040-120	60 x 40 x 6mm	120 Grit
TCRF6040-180	60 x 40 x 6mm	180 Grit
TCRF6040-220	60 x 40 x 6mm	220 Grit
TCRF8030-80	80 x 30 x 6mm	80 Grit

INDUSTRIAL

Part No.	Size (Shaft)	Grits	#/Box	Part No.	Size (Shaft)	Grits	#/Box
ABRF301060	30 x 10 x 6mm	60	100	ABRF602080	60 x 20 x 6mm	80	20
ABRF301080	30 x 10 x 6mm	80	100	ABRF603060	60 x 30 x 6mm	60	14
ABRF301580	30 x 15 x 6mm	80	100	ABRF603080	60 x 30 x 6mm	80	14
ABRF302060	30 x 20 x 6mm	60	90	ABRF604060	60 x 40 x 6mm	60	12
ABRF302080	30 x 20 x 6mm	80	90	ABRF604080	60 x 40 x 6mm	80	12
ABRF401060	40 x 10 x 6mm	60	50	ABRF605060	60 x 50 x 6mm	60	8
ABRF401080	40 x 10 x 6mm	80	50	ABRF605080	60 x 50 x 6mm	80	8
ABRF402060	40 x 20 x 6mm	60	50	ABRF802060	80 x 20 x 6mm	60	7
ABRF402080	40 x 20 x 6mm	80	50	ABRF802080	80 x 20 x 6mm	80	7
ABRF4020120	40 x 20 x 6mm	120	50	ABRF802580	80 x 20 X 6mm	80	7
ABRF403060	40 x 30 x 6mm	60	35	ABRF803060	80 x 30 x 6mm	60	7
ABRF403080	40 x 30 x 6mm	80	35	ABRF803080	80 x 30 x 6mm	80	7
ABRF502060	50 x 20 x 6mm	60	30	ABRF8030120	120 x 30 x 6mm	120	7
ABRF502080	50 x 20 x 6mm	80	30	ABRF804060	80 x 40 x 6mm	60	6
ABRF503060	50 x 30 x 6mm	60	20	ABRF804080	80 x 40 x 6mm	80	6
ABRF503080	50 x 30 x 6mm	80	20	ABRF805060	80 x 50 x 6mm	60	4
ABRF602060	60 x 20 x 6mm	60	20	ABRF805080	80 x 50 x 6mm	80	4

INDUSTRIAL



Bulk

Part No.	Size (Bore)	Grits	#/Box
ABRF155060	150 x 50 x 25mm	60	100
ABRF155080	150 x 50 x 25mm	80	100
ABRF205060	205 x 50 x 25mm	60	90
ABRF205080	205 x 50 x 25mm	80	90

INDUSTRIAL



Drum Sanders

Part No.	Size / Grit	Description
TCDS	15 - 50mm	Drum Sander Kit
TCDS0025	25.4mm	Drum Sander 6mm Shaft w/5 Pk Sanding sleeves
TCDS25	25.4mm	Drum Sander 6mm shaft
TCDS35	38mm	Drum Sander 6mm shaft
TC805060	60 Grit	Sanding Drum replacement sleeves 5/pk
TC805120	120 Grit	Sanding Drum replacement sleeves 5/pk
TC805180	180 Grit	Sanding Drum replacement sleeves 5/pk

Part No.	Size	Grits	Description
TCDS25080	25.4mm	80	Sanding Sleeve 5/Pack
TCDS25120	25.4mm	120	Sanding Sleeve 5/Pack
TCDS25180	25.4mm	180	Sanding Sleeve 5/Pack
TCDS35080	38mm	80	Sanding Sleeve 5/Pack
TCDS35120	38mm	120	Sanding Sleeve 5/Pack
TCDS35180	38mm	180	Sanding Sleeve 5/Pack



TCDS0025



Application/Material

- » Ideal for wood, fibreglass and metal
- » Ideal for sanding awkward, hard-to-reach places

Features/Benefits

- » Durable, resin abrasives easily handle toughest sanding jobs
- » 1/4" shank fits any electric drill



TCDS - Drum Sander Kit

- Contents;
- » 1 x 15mm, 1 x 20mm, 1 x 30mm, 1 x 40mm, 1 x 50mm

Sanding Glove Kit

Part No.	Description	
ABR70015	Sanding Glove with 3 Replacement sheets : 60, 80, 120 Grit	
ABR70016	Spare Sanding Sheet 60 Grit	5/pk
ABR70017	Spare Sanding Sheet 80 Grit	5/pk
ABR70018	Spare Sanding Sheet 120 Grit	5/pk
ABR70019	Spare Sanding Sheet 240 Grit	5/pk
ABR70021	Glove Shape Wool Polishing Bonnet	
ABR70020	Sanding Glove & 17 Piece Multi Use Kit	
Contents:		
» 1 Pce Sanding Glove		
» Sand screen - 1 x P80, 1 x P120, 1 x P220		
» Hook & Loop Disc (Red) - 2 x P40, 2 x P80, 1 x P120		
» Non-woven pad - 1 x P240 Green		
» Film Disc - 1 x P600, 1 x P800		
» Lambs Wool Polishing Bonnet - x 1		
» Sanding Sponge - x 1		
» Hook & Loop Disc (Yellow) - 1 x P180, 1 x P240, 1 x P320, 1 x P400		



IDEAL FOR:

- Drywall
- Wood
- Metal
- Cars and motorcycles
- Furniture
- Decorating

ADVANTAGES:

- Powerful hand control
- Protection
- Ease of use & control
- Breathable fabric
- Washable

Orbital Sanding

95 x 230mm		95 x 230mm		115 x 280mm		115 x 280mm	
5 Pack	Grits	5 Pk Plain	Grits	5 Pack	Grits	5 Pk Velcro	Grits
ABR45080	80	ABR46050	50	ABR48080	80	ABR49050	50
ABR45120	120	ABR46080	80	ABR48120	120	ABR49080	80
ABR45180	180	ABR46120	120	ABR48180	180	ABR49120	120
Hook & Loop No Holes		ABR46150	150	Plain No Holes		ABR49150	150
		ABR46180	180			Hook & Loop No Holes	
		Plain with 8 Holes					

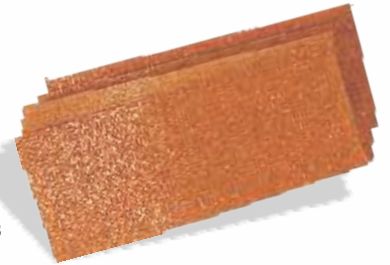

Application/Material

- Ideal for finishing wood, metal and fibreglass

Features/Benefits

- Designed for orbital sanding
- Premium, top-coated resin abrasive outlasts ordinary sandpaper
- Heavy weight sandpaper reduces tearing and lasts longer

Sanding Blocks

Part No.	Description
ABR70000	Sanding Block 165 x 85 for hand use
ABR70001	Sanding Block 210 x 105 for hand use
ABR70007	Sanding Block 126 x 68mm for hand use
ABR70013	Sanding Block Ergonomic 140 x 90mm for hand use
ABR70014	Sanding Block Ergonomic 122 x 66mm for hand use
SPC10101	Sanding Block Round PSA
SPC10102	Sanding Block Round Velcro
SPC10103	Hand Sanding Block Round 5" Hook & Loop System



SPC10102



ABR70000



ABR70013



ABR70007

Speed Files

Part No.	Description
ABR70010	Speed File Small (70 x 200mm) for hand use
ABR70011	Speed File Medium (70 x 250mm) for hand use
ABR70012	Speed File Large (70 x 390mm) for hand use

Part No.	Description
ABR70022	Speed File Small (70 x 170mm) for hand use
ABR70023	Speed File Medium (70 x 245mm) for hand use
ABR70024	Speed File Large (70 x 410mm) for hand use



ABR70010



ABR70022



ABR70023



ABR70011



ABR70012



ABR70024

Cabinet Paper

230 x 280mm			INDUSTRIAL
50 Pack	Type	Grits	
ABR100060	Coarse	60	
ABR100080	Coarse	80	
ABR100100	Medium	100	
ABR100120	Fine	120	
ABR100150	Fine	150	
ABR100180	Extra Fine	180	
ABR100220	Extra Fine	220	

Application

» Ideal for finishing wood & plastics

Premium Waterproof Paper

230 x 280mm		230 x 280mm		INDUSTRIAL
50 Pack	Grits	50 Pack	Grits	
ABR960060	60	ABR960360	360	
ABR960080	80	ABR960400	400	
ABR960100	100	ABR960600	600	
ABR960150	150	ABR960800	800	
ABR960180	180	ABR961000	1000	
ABR960220	220	ABR961200	1200	
ABR960240	240	ABR961500	1500	
ABR960320	320	ABR962000	2000	
		ABR962500	2500	

Application

» Ideal for finishing metal & steel
» Use wet or dry

Water Paper

230 x 280mm			
50 Pack	Grits	10 Pack	Grits
ABR103060	60	ABR103060-10	60
ABR103080	80	ABR103080-10	80
ABR103100	100	ABR103100-10	100
ABR103120	120	ABR103120-10	120
ABR103150	150	ABR103150-10	150
ABR103180	180	ABR103180-10	180
ABR103220	220	ABR103220-10	220
ABR103320	320	ABR103320-10	320
ABR103360	360	ABR103360-10	360
ABR103400	400	ABR103400-10	400
ABR103600	600	ABR103600-10	600
ABR103800	800	ABR103800-10	800
ABR1031200	1200	ABR1031200-10	1200

Application

» Ideal for finishing metal & steel
» Use wet or dry
» Kraft backing paper

Non Woven Pads

150 x 230mm					INDUSTRIAL
Part No.	Qty	Part No.	Qty	Description	
ABRN001	20	ABRN001-5	5	150 x 230mm Non Grain White	
ABRN002	20	ABRN002-5	5	150 x 230mm Ultra Fine Grey	
ABRN003	20	ABRN003-5	5	150 x 230mm Super Fine Maroon	
ABRN004	20	ABRN004-5	5	150 x 230mm Fine Green	
ABRN005	20	ABRN005-5	5	150 x 230mm Medium Black	

Application
» Ideal for rust cleaning, stainless steel polishing & wood polishing
» Use wet or dry

Sold in boxes of 50

Floor Paper Roll

300mm x 1M			INDUSTRIAL
Part No.	Type	Grits	
ABR102040	Coarse	40	
ABR102060	Medium	60	
ABR102080	Medium	80	
ABR102100	Fine	100	

Application

» General purpose use on wood, metal, plastic and painted walls

Order 50 for a box

Durasand Mesh Sanding Sheet

Dura Mesh Sanding Sheets

Part No.	Grits	Part No.	Grits
DURA040	40	DURA180	180
DURA060	60	DURA220	220
DURA080	80	DURA240	240
DURA100	100	DURA320	320
DURA120	120	DURA400	400
DURA150	150	DURA600	600

Application/Material

» Ideal for dry-walling

Features/Benefits

» Double-sided and non-clogging, silicone carbide grit
» Use wet or dry
» Can be used with vacuum system

Application/Material

» Ideal for wood, fibreglass, paint and metal
» For use with an orbital sander

Features/Benefits

» Double-sided and non-clogging

93 x 230mm		
Part No.	Grits	Pk Size
ABR43040	40	10/Pk
ABR43060	60	10/Pk
ABR43080	80	10/Pk
ABR43100	100	10/Pk
ABR43120	120	10/Pk
ABR43180	180	10/Pk
ABR43220	220	10/Pk
ABR43240	240	10/Pk
ABR43320	320	10/Pk
ABR43400	400	10/Pk
ABR43600	600	10/Pk



Tork Craft Pro Quality Angle Grinder Pads

Part No.	Description /Size
TCBP115-1	Angle Grinder Pad Pro made for 115 x 22mm Discs M14 x 2 Thread
TCBP115-2	Angle Grinder Pad Pro Soft for 115 x 22mm Discs M14 x 2 Thread
TCBP115-3	Angle Grinder Pad Pro Hard for 115 x 22mm Discs M14 x 2 Thread
TCBP178-1	Angle Grinder Pad Pro MED for 178 x 22mm Discs M14 x 2 Thread



TCBP115-1



TCBP178-1



Rubber Backing Pads



Part No.	Description
TCBP125C	Backing Pad & Arbor 125mm
TCBP150C	Backing Pad & Arbor 150mm

Application/Material

- Flexible rubber backing pads for sanding and/or polishing
- Use with "mm" wool bonnets and "ABR" Peel & Stick Sanding discs

Features/Benefits

- Flexible rubber allows for flat or contour sanding



TCBP125C

Paint & Rust Strippers



Part No.	Description
TCFA0205	5 Pce 50mm Paint & Corrosion Removal Kit
TCFA0207	7 Pce 50mm Surface Conditioning Kit
TCFA0307	7 Pce 75mm Surface Conditioning Kit
TCFA702B	Face Off Cup Disc 100mm Bulk for Angle Grinders
TCFA702C	Face Off Disc 100mm Carded for Drills
TCFA0703B	Face Off Disc 125mm Bulk for Drills
TCFA0703C	Face Off Disc 125mm Carded for Drills
TCFA0706	Face Off Disc & Arbor 100mm Carded for Drills
TCFA0707	Face Off Disc & Arbor 125mm for Drills
TCFA02001	10 Pc 50mm Non Woven Disc Screw Type BLUE Fine for Surface Cond.
TCFA02002	10 Pc 50mm Non Woven Disc Screw Type BROWN Coarse for Surface Cond.
TCFA02003	10 Pc 50mm Non Woven Disc Screw Type RED Medium for Surface Cond.
TCFA02010	Plastic Backing Pad Screw Type with Arbor for Surface Conditioning Kit
TCFA02060	10 Pc 50mm Sand Disc Screw Type 60G for Surface Conditioning Kit
TCFA02120	10 Pc 50mm Sand Disc Screw Type 120G for Surface Conditioning Kit
TCFA02180	10 Pc 50mm Sand Disc Screw Type 180G for Surface Conditioning Kit
TCFA02320	10 Pc 50mm Sand Disc Screw Type 320G for Surface Conditioning Kit
TCFA02600	10 Pc 50mm Sand Disc Screw Type 600G for Surface Conditioning Kit



TCFA702B



TCFA0307



TCFA0205

Angle Grinder Pin Spanners

Part No.	Description
TCPS3504	Pin Spanner 35 x 4mm
TCPS3505	Pin Spanner 35 x 5mm



Fits most Angle Grinders



Application/Material

- Strips paint and rust without clogging or damaging the surface
- Use on wood or steel
- Strong nylon mesh for longer life
- With silicone carbide grit for maximum stripping power

Polishing & Sanding Machines

POL02 : Angle Sander Polisher

SPECIFICATIONS

Capacity : 180mm
 Rated Voltage : 230V
 Rated Input Power : 1200W
 No Load Speed : 1100 - 3500rpm
 Thread Size : M14
 Weight : 2.54kg

Accessories Included:

- » 1 Pce Velcro backing Pad 180mm
- » 1 Pce 180mm velcro Wool Polishing Bonnet
- » 1 Pce Hex wrench
- » 1 Extra Pair Carbon Brush



Constant Power!



POL04 : Random Orbital Polisher/Sander

SPECIFICATIONS

Capacity : 150mm
 Rated Voltage : 220V
 Rated Input Power : 800W
 No Load Speed : 2000 - 6400rpm
 Spindle Thread : 5/16F - 24T
 Weight : 2.30kg

Accessories Included:

- » Velcro Polishing Pad 5/16M - 24T 150mm/6"
- » 1 Pce 25mm x 150mm Velcro compound sponge
- » 1 Pce Auxillary Handle
- » 1 Pce Wrench
- » 1 Extra Pair Carbon Brush
- » 1 Pce Hex Wrench



Constant Speed!



POL05 : 1200W Polisher & Sander

SPECIFICATIONS

Capacity : 180mm
 Rated Voltage : 220V
 Rated Input Power : 1200W
 No Load Speed : 1000 - 3000rpm
 Spindle thread : M14
 Weight : 2.33kg

Accessories Included:

- » 1 Pce Velcro Polishing Pad 180mm/7" M14M
- » 1 Pce TorkCraft Wool Polishing Bonnet
- » 1 Pce Auxillary Handle
- » 1 Pce D-handle
- » 1 Pce Front Cover
- » 1 Pce Hex Key
- » 1 Extra Pair Carbon Brush

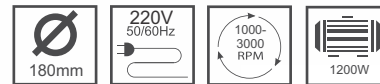

Constant Power!



POL06 : 1500W Polisher/Sander

SPECIFICATIONS

Capacity : 180mm
 Rated Voltage : 220V
 Rated Input Power : 1500W
 No Load Speed : 1000 - 3000rpm
 Spindle Thread : M14
 Weight : 2.94kg

Accessories Included:

- » 1 Pce Velcro Polishing Pad 180mm/7" M14M
- » 1 Pce Wool Polishing Bonnet
- » 1 Pce D-handle
- » 1 Pce Hex Key
- » 1 Extra Pair Carbon Brush

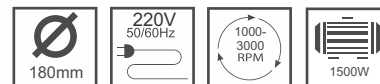

Constant Power!



Colour of machines may change

Sander Pads/Sponges

Part No.	Description
Adaptors	
SPC00051	M14 M x 8mm Spindle
SPC00052	M14 M x M14 F
SPC00053	5/8" M x 5/8" F
SPC00054	M14 M x 5/8" F
SPC00055	5/8" x 5/8"
200mm / 8" Foam Pad	
SPC00100	Foam Pad Yellow Finishing Sponge 200mm/8"
SPC00101	Foam Pad Orange Cutting Pad 200mm/8" Velcro
SPC00102	Foam Pad Red Polishing Pad 200mm/8" Velcro
SPC00103	Foam Pad Black Finishing Pad Sponge 200mm/8"
Microfibre Cloth	
SPC00104	Microfibre Cloth Blue (400 x 400mm)
Backing Pad	
SPC00106	Backing Pad M14 x 178mm - For 8"/200mm foam pads
SPC00117	100mm x M14 for Stone polishing super pads Hook & Loop
SPC00118	100mm x 5/8" UNC for Stone polishing super pads Hook & Loop
SPC00119	150mm x M14 x 2 for Concave Wool Bonnets Hook & Loop
SPC00120	125mm x M14 Hook & Loop with 8mm Spindle
SPC00121	125mm/5" Sanding & Polishing Kit w/400-600 Grit pads
SPC00122	125mm Hook & Loop with 8mm Spindle
SPC00126	115mm Hook & Loop x M14 with 8mm Spindle
SPC00127	150mm Hook & Loop x M14 with 8mm Spindle
Sander Pad - DA (Dual Action)	
SPC00107	6" Sander Pad 6 holes 5/16 - 24 UNF : Hook & Loop
SPC00108	6" Sander Pad 52 holes 5/16 - 24 UNF : Hook & Loop
SPC00109	6" Sander Pad PSA 5/16 - 24 UNF Medium Soft
SPC00110	6" Sander Pad Hook & Loop 5/16 - 24 UNF Medium Soft
SPC00111	5" Sander Pad PSA 5/16 - 24 UNF Medium Soft
SPC00112	5" Sander Pad Hook & Loop 5/16 - 24 UNF Medium Soft
SPC00113	5" Sander Pad Hook & Loop 5/16 - 24 UNF 8 Hole Med Soft
Polishing Wool Bonnet/Sponge	
SPC00123	125mm 5" Polishing Wool Bonnet Hook & Loop
SPC00125	180mm 7" Concave Polishing Wool Bonnet Hook & Loop
SPC00124	125mm 5" Polishing Sponge Hook & Loop
Interface Cushion Pad	
SPC00129	150mm Hook & Loop No holes
SPC00130	150mm Hook & Loop 6 Holes

INDUSTRIAL

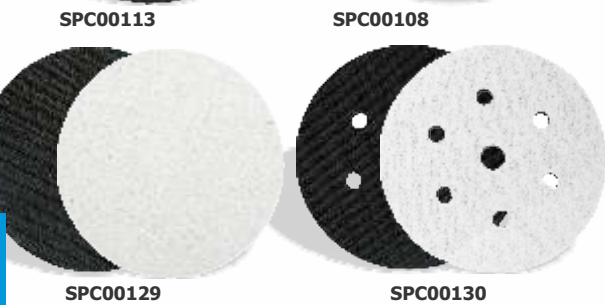
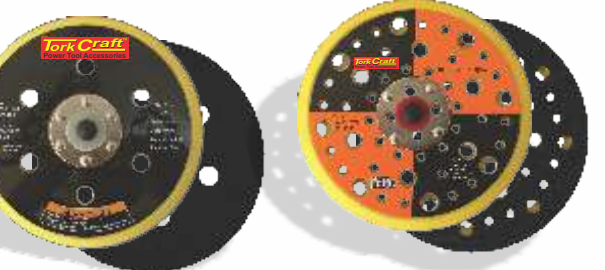

Foam Pads Velcro

Part No.	Description
SPC00200	Yellow Sponge 150mm / 6" for heavy cutting
SPC00201	Maroon Sponge 150mm / 6" for heavy compounding
SPC00202	Yellow Sponge 150mm / 6" for Compounding
SPC00203	Orange Sponge 150mm / 6" for light compounding
SPC00204	Blue Sponge 150mm / 6" for heavy polishing
SPC00205	Black Sponge 150mm / 6" for finishing
SPC00206	Green Sponge 150mm / 6" for light finishing
SPC00207	Red Sponge 150mm / 6" for ultra finishing
SPC00208	White Sponge 150mm / 6" for cutting

INDUSTRIAL



Compounding Sponge

Part No.	Description	» MAXIMUM RPM 2500
TCCS15014	150mm x M14 Standard Orange	
TCCS15014-1	150mm x M14 Premium White	
TCCS15014-2	150mm x M14 Red	
TCCS15014-3	150mm x M14 Black	
TCCS15014-4	150mm x M14 HARD White	
TCCS15014-5	150mm x M14 Black Waffle SOFT	
TCCS15014-6	150mm x 45mm x M14 Plastic thread Premium White	
TCCS15058	150mm x 5/8 White	



TCCS15014-2



TCCS15014-3



TCCS15014-5



TCCS15058

Order 50 for a box



TCCS15014



TCCS15014-1



TCCS15014-4



Wool Polishing Bonnets

Part No.	Description
MM4	4" 100mm Polishing Wool Bonnet - Tie-on
MM5	5" 125mm Polishing Wool Bonnet - Tie-on
MM6	6" 150mm Polishing Wool Bonnet - Tie-on
MM7	7" 180mm Polishing Wool Bonnet - Tie-on
MM7-2	7" 180mm Polishing Wool Bonnet - Tie-on 100% on Sheepskin
MM8	8" 200mm Polishing Wool Bonnet - Tie-on
MM9	9" 230mm Polishing Wool Bonnet - Tie-on
MM9-2	9" 230mm Polishing Wool Bonnet - Tie-on 100% on Sheepskin
MM10	10" 250mm Polishing Wool Bonnet - Tie-on
MM DS7	7"/180mm Double-sided Wool Buff with M14 F Thread 100% Wool
MM DS7-2	7"/180mm 180mm Double-sided Wool Buff with 5/8" Thread 100%
MM DS9	9" 230mm Double-sided Wool Buff with M14 Thread 100%
MM DS9-2	9" 230mm Double-sided Wool Buff with 5/8" Thread 100%



Application/Material

Tie on wool bonnet
For use with the following rubber backing pads;
- TCBP125C (125mm) w/arbor
- TCBP150C (150mm) w/arbor
- Flex40310 (225mm) M14 x 2mm
- PG33805 (180mm)
- PG338 (125 x 6mm)

Plastic Spreader

3 Pce Plastic Spreader Set
101, 133 & 158mm

PART NO. BR011

Use with body fillers, fiberglass resin, putty etc. Gives a smooth finish which means less sanding.
REUSABLE...just bend and hardened material will pop off spreader



Buffing & Polishing Compound

CLEANING & POLISHING POLISHING BARS



INDUSTRIAL

RCC 20 - AB ± 1.2KG

Description: General purpose **medium** cutting colouring buffing compound for brass, copper & silver.
Application: Brick-type buffing compound applied to the surface of the buffing wheel by hand.
Specification: Physical state 25°C. Red solid bar. Product contains fatty acids and a mixture of silica and tripoly as an abrasive filler

RCC 11 - SD ± 1.3KG

Description: A **finishing** compound for steel, chrome and aluminium
Application: Brick-type buffing compound applied to the surface of the buffing wheel by hand.
Specification: Physical state 25°C. Grey solid bar. Product contains fatty acids, waxes and mixture of silica and tripoly as an abrasive filler

RCC 12-S ± 1.4KG

Description: A **cutting and buffing** compound for steel, stainless steel, chrome and aluminium.
Application: Brick-type buffing compound applied to the surface of the buffing wheel by hand.
Specification: Physical state 25°C. Brown solid bar. Product contains fatty acids, waxes and a mixture of silica and tripoly as an abrasive filler

INDUSTRIAL

RCC 1 SDDB ±1.15KG

Description: Bright finishing compound for stainless steel

RCC G-13

Description: A **light green cutting** compound for stainless steel, aluminium & alum alloys

RCC G-14

Description: A **dark green finishing** compound for all metals

RCC SW-1

Description: A **purple cutting** compound for stainless steel

INDUSTRIAL

RCC SW-2000

Description: A **yellow cutting** compound for coppers, brass, aluminium, brass and steel

RCC SW-3

Description: A **white solid cutting** compound for stainless steel



Headlamp Restoration Kit

SPC00128

Headlamp Lens Restoration Kit

Restore the clarity of yellowed, hazed or dull headlight lenses and improve night visibility with this headlight cleaner kit

- Water based
- Contains no silica, silicone, waxes or clay fillers



Clean and Renew **12!**
Two Headlights in just **MINUTES**

Polishing Buffs



Part No.	Description	INDUSTRIAL
White Stitched Buff		
TCBF100-2W	100mm 2 Section x 20mm 1/2" Arbor	
TCBF150-2W	150mm 2 Section x 20mm 1/2" Arbor	
TCBF150-3W	150mm 3 Section x 30mm 1/2" Arbor	
TCBF200-2W	200mm 2 Section x 20mm 1/2" Arbor	
TCBF200-3W	200mm 3 Section x 30mm 1/2" Arbor	
White Buff Unstitched		
TCBF150-50W	150 x 50 Ply x 1/2" Arbor	
TCBF200-50W	200 x 50 Ply x 1/2" Arbor	
Colour Stitched Buff		
TCBF150-2C	150mm 2 Section x 30mm 1/2" Arbor	
TCBF150-3C	150mm 3 Section x 30mm 1/2" Hole	
TCBF200-2C	200mm 2 x 20mm 1/2" Arbor	
Buffing Wheel Kits		
TCBF10030	3 Pce Kit 100mm White & Denim Stitched & Sisal Polishing	
TCBF15030	3 Pce Kit 150mm White & Denim Stitched & Sisal Polishing	

White Buffs : Application/Material

- Ideal for buffing all types of steel, brass, aluminium, copper, stainless steel etc.
- For use with buffing compounds

Unstitched buffs for softer application.
Stitched buffs for more aggressive use.
Cotton buffs are manufactured in both Loose Leaf or Stitched form. Each leaf/fold is approximately 1mm thick.

Colour Buffs : Application/Material

This is a general purpose buff, used in conjunction with various grades of polishing compounds. It will give the desired finish on steel, stainless steel, brass, copper, aluminium etc.

Colour buffs are coarser than white buffs.



TCBF150-50W



TCBF150-2W



TCBF150-2C



Taper Adaptors (Pigtail)

Part No.	Description
TCPT012-01	Taper for Bench Grinders 12mm Left-hand
TCPT012-02	Taper for Bench Grinders 12mm Right-hand
TCPT016-01	Taper for Bench Grinders 16mm Left-hand
TCPT016-02	Taper for Bench Grinders 16mm Right-hand

Part No.	Description
TC801201	Cotton Buff only 75mm Carded
TC801203	Cotton Buff only 100mm Carded
TC801707	Cotton Buff White Stitched 75mm x 6mm Shank
TC801709	Cotton Buff White Stitched 100mm x 6mm Shaft
TC801730	3 Pce White Buff Set



TC801707

TC801730

Buffing Pads



Part No.	Description
TC872000	Medium buffing pad 100mm to fit 12.5mm arbor/spindle
TC872100	Medium buffing pad 150mm to fit 12.5mm arbor/spindle
TC872110	Firm buffing pad 150mm to fit 12.5mm arbor/spindle



TC872000



TC872110



TC872100

Cleaning & Polishing Compounds



Part No.	No. #	Description/Application
TC871101	1	For heavy duty cleaning of hard materials
TC871301	3	For regular cleaning of soft metals
TC871401	4	For regular cleaning of precious metals
TC871501	5	For light polishing / light cleaning of all materials
TC871601	6	For high gloss polishing of all materials, including precious metals



Cleaning & Polishing Kits



TC874020 : Cleaning & Polishing Kit for soft metals
Complete Kit to remove scratches & polish soft metals such as brass, copper, tin, pewter & aluminium (with 12.5mm Arbor)



Part No. TCW006-3
5 Pce Polishing, Buffing & Compound Kit w/Felt Buff for drill



TC804901
Buffing & Compound Kit
Order 50 for a box



TC804904
5 Pce Polishing Compound Kit
» Use to buff and polish all types of steel
» 5 grits of polish for a perfect finish
» 1/4" shank fits any drill



Polishing, Buffing & Compound Drill Set
65, 75 & 100mm Buffing Wheels
PART NO. TCW006-1



Polishing and Burnishing Machines

MY3015-2 : Stainless Burnishing Machine

Specifications

- Long Handle
- 100 x 120mm Discs
- Power Input : 800W
- No Load Speed: 900 - 2800 R/min
- Rated Voltage: 220V - 50Hz

Belts For Machine

MY3015-2-3	80 Grit Flap Grinding Wheels 120mmx100mm
MY3015-2-4	120 Grit Flap Grinding Wheels 120mmx100mm
MY3015-2-5	240 Grit Flap Grinding Wheels 120mmx100mm
MY3015-2-6	80 Grit Nylon Grinding Wheels 120mmx100mm
MY3015-2-7	100 Grit Nylon Grinding Wheels 120mmx100mm
MY3015-2-8	120 Grit Nylon Grinding Wheels 120mmx100mm
MY3015-2-9	240 Grit Nylon Grinding Wheels 120mmx100mm
MY3015-2-10	320 Grit Nylon Grinding Wheels 120mmx100mm

INDUSTRIAL



This machine is used for grinding, polishing and fine polishing of stainless steel metals, plastics and woods.

MY3015R03B

MY3016-2 : Stainless Pipe Polisher

Specifications

- Long Handle
- Power Input : 800w
- Voltage: 220V-50Hz
- No Load Speed : 900-2800 R/min
- Maximum Belt Length: 760mm
- Maximum Belt Width: 40mm
- Covers 270 Degrees of pipe
- Speed Control

Belts For Machine

MY3016-2-3	60 Grit Zirconia Sanding Belts
MY3016-2-4	80 Grit Zirconia Sanding Belts
MY3016-2-5	1000 Grit Zirconia Sanding Belts
MY3016-2-6	1500 Grit Zirconia Sanding Belts
MY3016-2-7	2000 Grit Zirconia Sanding Belts
MY3016-2-8	Nylon Belt Coarse 40mmx760mm
MY3016-2-9	Nylon Belt Medium 40mmx760mm
MY3016-2-10	Nylon Belt Fine
MY3016-2-11	Fleece Felt Belts



Used for grazing, tarnishing, texturing, polishing and smoothing pipes. Without the use of water .



MY3025 : Tube Belt Sander/Polisher

Specifications

- Power Input: 1200W
- Voltage: 220v-50Hz
- No Load Speed: 900-2800 R/min
- Maximum Belt Length: 620mm
- Maximum Belt Width: 40mm
- Quick Tool Free Belt Change
- High Stability Pulleys
- Front Handle
- Speed Control
- Trigger Switch
- Motor

Belts For Machine

MY3025-2-3	60 Grit Zirconia Sanding Belts 40mm x 620mm
MY3025-2-4	80 Grit Zirconia Sanding Belts 40mm x 620mm
MY3025-2-5	1000 Grit Zirconia Sanding Belts 40mm x 620mm
MY3025-2-6	1500 Grit Zirconia Sanding Belts 40mm x 620mm
MY3025-2-7	2000 Grit Zirconia Sanding Belts 40mm x 620mm
MY3025-2-8	Nylon Belt Coarse 40mm x 620mm
MY3025-2-9	Nylon Belt Medium 40mm x 620mm
MY3025-2-10	Nylon Belt Fine 40mm x 620mm
MY3025-2-11	Fleece Felt Belts 40mm x 620mm



Measuring

Part No.	Description	Accuracy
Vernier Caliper		
ME10150	150mm Carbon Steel	±0.02mm
ME10200	200mm Carbon Steel	±0.02mm
ME11150	150mm Stainless Steel	±0.02mm
ME11200	200mm Stainless Steel	±0.02mm
ME11300	300mm Stainless Steel	±0.02mm
Vernier Digital Fractional / ABS Function		
ME12150	150mm Stainless Steel	±0.01mm
ME12200	200mm Stainless Steel	±0.01mm
ME12300	300mm Stainless Steel	±0.01mm
Vernier Digital - Carbon Fibre		
ME13150	150mm Carbon Fibre	±0.1mm
Vernier Digital 4 Key / ABS/Zero Function		
ME14150	150mm Stainless Steel	±0.01mm
ME14200	200mm Stainless Steel	±0.01mm
ME14300	300mm Stainless Steel	±0.01mm
Micrometer Manual		
ME20025	0 - 25mm	±0.01mm
ME20050	25 - 50mm	±0.01mm
ME20075	50 - 75mm	±0.01mm
Micrometer Digital		
ME30025	0 - 25mm	±0.01mm
ME30050	25 - 50mm	±0.01mm
ME30075	50 - 75mm	±0.01mm
Memory Hold		
ME15150	0 - 150mm	±0.01mm



Rulers - Stainless Steel

Part No.	Description	Metric Sizes
ME01015	Stainless Steel Ruler	150 x 19 x 0.8mm
ME01030	Stainless Steel Ruler	300 x 25 x 1.0mm
ME01060	Stainless Steel Ruler	600 x 30 x 1.2mm
ME01100	Stainless Steel Ruler	1000 x 35 x 1.5mm
ME02030	Aluminium Straight Edge Ruler	300 x 50 x 5mm
ME02060	Aluminium Straight Edge Ruler	600 x 50 x 5mm
ME02100	Aluminium Straight Edge Ruler	1000 x 50 x 5mm
RULER 01	Stainless Steel Ruler Cork Backed	300mm Red
RULER 02	Stainless Steel Ruler Cork Backed	300mm Blue

STAINLESS STEEL



ALUMINIUM



Part No. ME00005
Mini Plastic Folding Ruler
on Key Ring 500mm



Part No. ME00020
Wooden Folding Ruler
2m with 10 Folds



RULER 01

RULER 02



Measuring Tapes

Part No.	Description
ME05316	Measuring Tape Auto Lock 3M x 16mm Rubber Casing Matt finish
ME05519	Measuring Tape Auto Lock 5M x 19mm Rubber Casing Matt finish
ME05825	Measuring Tape Auto Lock 8M x 25mm Rubber Casing Matt finish
ME06316	Measuring Tape Multi Lock 3M x 16mm Rubber Casing Matt finish
ME06519	Measuring Tape Multi Lock 5M x 19mm Rubber Casing Matt finish
ME06525	Measuring Tape Multi Lock 5M x 25mm Long Life Contractor Quality
ME06825	Measuring Tape Multi Lock 8M x 25mm Rubber Casing Matt finish
ME06100	Measuring Tape Multi Lock 10M x 25mm Rubber Casing Matt finish
ME06030	Measuring Tape Fibreglass 30M x 13mm Heavy Duty ABS Case
ME06050	Measuring Tape Steel Blade 50M x 13mm Co-molded Rubber Casing
ME07003	Measuring Tape Manual Lock 3M x 16mm Plastic Casing
ME7003-1	Measuring Tape Dispensing Box (12x ME7003)
ME7005	Measuring Tape Manual Lock 5M x 25mm Plastic Casing
ME7005-1	Measuring Tape Dispensing Box (12x ME7005)
ME7008	Measuring Tape Manual Lock 8M x 25mm Plastic Casing
ME7008-1	Measuring Tape Dispensing Box (12x ME7008)
ME07358	4 Pce Measuring Tape Set (1M, 3M, 5M & 8M)
ME07825	Measuring Tape Blotting 8M x 25mm Rubber Casing Matt finish
ME08358	3 Pce Measuring Tape Set : 3m, 5m & 8m Plastic Casing



ME07003-1



ME05825



ME06525

WIDE 25mm blade



ME07825

ME07003

0.5ml Red Oil Based Ink

ME06030

Measuring Tape Fibreglass 30M x 13mm

- » Ideal for Contractors & Surveyors
- » Design allows easy cleaning of tape
- » Long winder with easy grip knob facilities & quick rewinding
- » Fiberglass tapes are safe from electrical hazards
- » Heavy duty ABS case
- » Bold numbers for easier reading

ME06050

Measuring Tape Steel Blade 50M x 13mm

- » 6 x High Speed Gear Mechanism: Turn handle once & tape rewinds 6x
- » High carbon steel blade coated w/acrylic polymers for long life
- » Easy to read bold black numbers on 13mm wide yellow blade
- » Ideal for high precision professional jobs
- » Co-moulded rubber case

6:1 + Quick release handle
Fast wind in

QUICKDRAW™
PRECISION MEASURING
Self-Marking



QD5M-PRO : Self-marking Measuring Tape 5M
QD8M-PRO : Self-marking Measuring Tape 8M

TruView WEDGE Indicator
Easy & Fast Reload
Rugged Construction
Lock the Blade to Draw Circles
Patented RollMark Technology

Built-in Graphite marker

Graphite storage marker keychain



Letter & Number Punches

Part No.	Description
TCNP005	Number Punch Set 5mm (0 - 9)
TCNP006	Number Punch Set 6mm (0 - 9)
TCNP008	Number Punch Set 8mm (0 - 9)
TCNP010	Number Punch Set 10mm (0 - 9)
TCLP005	Letter Punch Set 5mm (A - Z), &
TCLP006	Letter Punch Set 6mm (A - Z), &
TCLP008	Letter Punch Set 8mm (A - Z), &
TCLP010	Letter Punch Set 10mm (A - Z), &



Carpenters Pencil

Part No.	Description
PEN07	7 Pce Carpenters Pencil Set : 6 x Pencils & 1 x Sharpener
PEN10	Carpenters Pencil 175mm : 12 per box
» Professional sharpening tool designed specifically for carpenters pencils	
» Gives a clean sharp point, Safer & easier than a utility knife	
» Compact & durable design, 175mm length	
PEN01	Vermont Sales Ballpoint Pen Red & White
PEN02	TorkCraft Recycled Paper Ballpoint Pen
PEN20	Mechanical Carpenters Pencil c/w 3 Dura Lead refills
PEN20-2	Mechanical Carpenters Pencil BULK
PEN20-3	Mechanical Carpenters Pencil Dura Lead Refill WHITE 5Pc
PEN20-4	Mechanical Carpenters Pencil Dura Lead Refill RED 5Pc
PEN20-5	Mechanical Carpenters Pencil Dura Lead Refill YELLOW 5Pc

NO MORE SHARPENING!

Dura lead lasts 3x longer than traditional carpenter pencils

- » Ideal for lumber, metal, ceramic & concrete



PEN20



PEN10



PEN07

Part No. **PEN040**
40 Pce Display Jar of Carpenters Sharpeners



Part No. **PEN13**
13 Pce Measuring Tool Set

- » 1 x Square Ruler
- » 1 x 3m Measuring Tape
- » 1 x Sharpener
- » 10 x Carpenters Pencils



Nibbler Sheet Metal Cutter

Part No.	Description	INDUSTRIAL
TC10008	Sheet Metal Nibbler	
TC10009	Nibbler attachment with extended shaft	
TC10010	Nibbler Jigsaw attachment	
TC10011	Spare Cutting Blade Guide TC10010	
TC10012	Spare Cutting Blade for TC10010	
TC10013	Spare Straight & Round Cutting Blade	
TC10014	Table Top Mounting for Nibbler	
TC10015	Circular Nibbler Attachment	
TC YT 160-1	Toolrest Spare part	
TC YT 160-2	Spare Cutter for TC10008	
TC YT 160-3	Spare Cutter for TC10009	
TC YT 160-4	Tabletop Mounting for TC10008	

For circular & irregular shape cutting

- » Unique convenience and durability
- » Excellent cutting speed of 2 metres/min at 3000RPM.
- » Excellent cutting result without any burrs at the cut edges
- » 360° changeable direction while operating
- » Can be fitted to any electric or power drill, max 3000RPM
- » Different cutting shapes available
- » Capacity : Cuts mild steel up to 1.8mm, cuts stainless steel up to 1.2mm, cuts aluminium up to 2mm thick, cuts plastic or plywood up to 2mm
- » Replacement blades easy to change

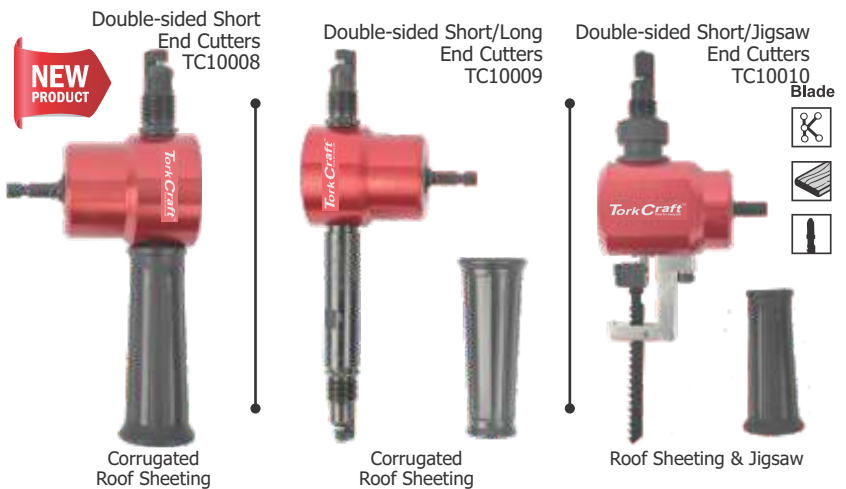

Corrugated Roof Sheeting

Corrugated Roof Sheeting

Roof Sheeting & Jigsaw



Paint Marker

Part No.	Description
TCPM0001	Paint Marker Red 1 Pce Bulk
TCPM0002	Paint Marker Yellow 1 Pce Bulk
TCPM0003	Paint Marker White 1 Pce Bulk
TCPM0004	Paint Marker Black 1 Pce Bulk
TCPM0005	Paint Marker Blue 1 Pce Bulk
TCPM0012	12 Pk Paint Markers Red/Yellow/White/Black/Blue
TCPM0036	36 Pce Paint Markers Bulk Tub Red/Yellow/White/Black/Blue



TCPM0036



Marks on;

- » Metal
- » Stone
- » Glass
- » Rubber
- » Plastic
- » Wood
- » Leather



Hot Melt General Purpose Glue Sticks

Part No.	Description
TCGS07200-01	7 x 200mm, 12Pc EVA 18000CPS
TCGS07200-02	7 x 200mm, 125Pc 1KG EVA 18000CPS
TCGS07300-01	7 x 300mm, 12Pc EVA 18000CPS
TCGS07300-02	7 x 300mm, 82Pc 1KG EVA 18000CPS
TCGS11200-01	11 x 200mm, 12Pc EVA 18000CPS
TCGS11200-02	11 x 200mm, 52Pc 1KG EVA 18000CPS
TCGS11300-01	11 x 300mm, 12Pc EVA 18000CPS
TCGS11300-02	11 x 300mm, 35Pc 1KG EVA 18000CPS

Available:
Both in 200mm and
300mm lengths



- 15 sec. curing
- 18000cps Viscosity
- EVA
- Adhesive
- Non-Toxic
- Not waterproof

- » Use with hot melt glue guns
- » General Purpose - Indoor use & art
- » Bonds PVC, wood, material, paper & more
- » Melting temperature = 80°C
- » Paintable afterwards
- » Transparent colour
- » Non-toxic but not recommended for the food industry
- » Viscosity = 18,000cps
- » Cures in 15 seconds under normal conditions

Hot Melt Glue Guns

TCGG05001	10W, 220V, 7mm, Flow rate 6-8G, 7 Min. Pre-heat
TCGG05002	40W, 220V, 11mm, Flow rate 8-12G, 5 Min. Pre-heat
TCGG05004	80W, 220V, 11mm, Flow rate 14-16G, 5 Min. Pre-heat



Laser Distance Meters

Part No.	Description
TCLDM00S6	Laser Distance Meter

The maximum measuring range	60m
Measuring accuracy	±1.5mm
Measuring units	m / in / ft
Area / Volume Measurement	✓
Addition / Subtraction	✓
Single distance measurement	✓
4-line display with backlight	✓
Continuous distance measurement (Min/Max)	✓
Historical data	20 sets
Auto laser off	30 seconds

60m RANGE



- » End-piece & calibrated scale
- » Batteries included
- » Max Distance 60m range
- » Area measurement
- » Volume measurement
- » Shatterproof screen
- » Belt pouch & screwdriver included

Part No.	Description
TCLDM00D110	Laser Distance Meter

Specification	
The maximum measuring range ¹	0.2~20m
Measuring accuracy ²	±3 mm
Measuring units	m
Laser class	Class 2
Laser type	630-670nm, < 1mW
Single / Continuous measurement	✓
Button	Soft rubber buttons
Operating temperature	0°C~40°C
Storage temperature	-10°C~60°C
Battery life	5,000 measurement times
Battery type	AAA 2 x 1.5V
Auto laser off	30 seconds
Dimensions (mm)	100.5*38*24.5

20m RANGE



- » Easily take single & continuous measurements
- » Max Distance 20m range
- » Batteries included

TCRF00PF220 Laser Rangefinder 600m

Field of View	7°
Scope Magnification	6x
Objective Lens Diameter	22mm
Eyepiece Lens Diameter	16mm
Exit Pupil Diameter	3.7mm
Diopter	±5D
Angle Accuracy	±1°
Measuring Accuracy	±0.5m
Measuring Unit	m
Operating Temperature	0°C ~ 40°C
Wavelength	600m

600m RANGE

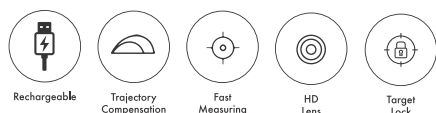

Part No.	Description
TCLDM00D8	Laser Distance Meter

The maximum measuring range	40m
Measuring accuracy	±2mm
Measuring units	m
Continuous measurement	✓
Min. / max. value	✓
4-line display with backlight	✓
Single distance measurement	✓
Auto laser off	30 seconds



- » Batteries included
- » Area measurement
- » Max Distance 40m range

40m RANGE



Part No.	Description
TCDMD001	Digital Metal Detector

- » MAX SCANNING DEPTH UP TO 80mm
- » Detects materials such as ferrous & non-ferrous metals & wood
- » Indicates specific location of detected material
- » Sound & light alarm
- » Batteries not included

Maximum Scanning Depth	» Ferrous metals : 80mm » Non-ferrous metals (Copper) : 60mm » Copper Conductors (Live)** : 50mm » Wood : 20mm
Automatic switch off after approx.	5min
Operating temperature	-10°C ~ +50°C
Storage temperature	-20°C ~ +70°C
Battery	1 x 9V
Operating lifetime (approx)	6h
Dimensions	199mm x 81.5mm x 20.5mm
Weight	Approx 160g (excluding battery)

* Depends on material and size of objects as material and condition of structure
* Less scanning depth for wires/conductors that are not "live"



Digital Depth Gauge

Part No. Description

- | | |
|---------|--------------------------|
| ME09060 | Digital Depth Gauge 60mm |
|---------|--------------------------|
- » To set router cutter or saw blade height
 - » Horizontal & vertical measuring
 - » Hole depth measuring 50.8mm
 - » Self standing for setting cutter depth on router tables
 - » Measuring rule w/metric/imperial scale & locking screw
 - » Digital display for easy reading
 - » 60mm wide aperture
 - » Magnets in base



Omnifall Level Gauge

**NEW
PRODUCT**

TCOF001
Omnifall Level Gauge

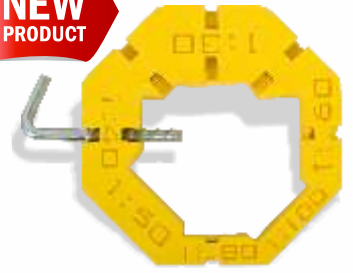

Steel Profile Contour Gauge

Part No. Description

- | | |
|---------|--------------------------------|
| ME04150 | 150mm - Max profile depth 45mm |
|---------|--------------------------------|
- Fine steel pins for accurate profile copying
 - Great for tracing irregular shapes to make moulds
 - Pins slide out to give the exact shape of the measured object
 - Maximum profile depth 45mm
 - Metric & Imperial measurements
 - Multiple uses, including woodworking, carpet-fitting and floor laying



Plastic Profile Contour Gauge

Part No. Description

- | | |
|---------|--------------------------------|
| ME04200 | 200mm - Max profile depth 45mm |
|---------|--------------------------------|
- Fine plastic pins for accurate profile copying
 - Great for tracing irregular shapes to make moulds
 - Pins slide out to give the exact shape of the measured object
 - Maximum profile depth 45mm
 - Metric & Imperial measurements
 - Multiple uses, including woodworking, carpet-fitting and floor laying

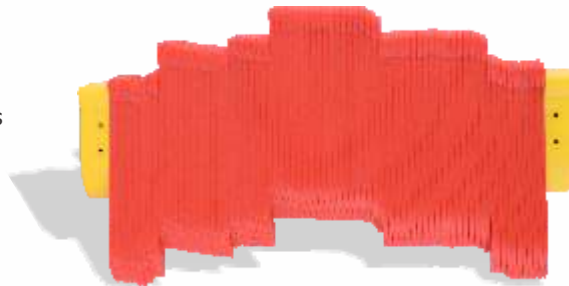

Carpenters Square

Part No. Description

- | | |
|---------|--------------------------------|
| ME03300 | Carbon Steel 300 x 200 x 2.0mm |
| ME03600 | Carbon Steel 600 x 400 x 2.0mm |



Combination Square

ME09030
Aluminium Handle
Combination Square 300mm



Tri Handle Square

Part No. Description

- | | |
|---------|-----------------------------------|
| ME08150 | Aluminium Tri Handle Square 150mm |
| ME08200 | Aluminium Tri Handle Square 200mm |
| ME08300 | Aluminium Tri Handle Square 300mm |

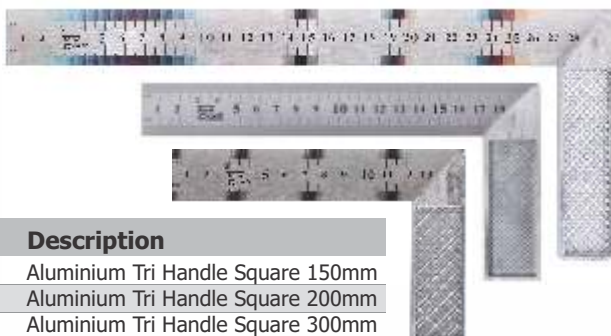

Wood Storage Racks

Part No.	Description
TCWRA003	3 Level Storage Rack
TCWRA006	6 Level Storage Rack



Cooler Boxes



5.8
KG

Product Weight



Durable

20
Litres



- » 20 Litre Cooler Box
- » ABS latches
- » Corrosion resistant
- » Heavy duty & shock proof
- » Diameter : 331 x 196 x 367mm
- » Stainless Steel hardware for long life
- » Heat Insulated made from Polypropylene
- » Ice retention for up to 7 days (depending on ambient temp)
- » Available in White, Green & Grey

PLC19010 : White
PLC19020 : Green
PLC19030 : Grey

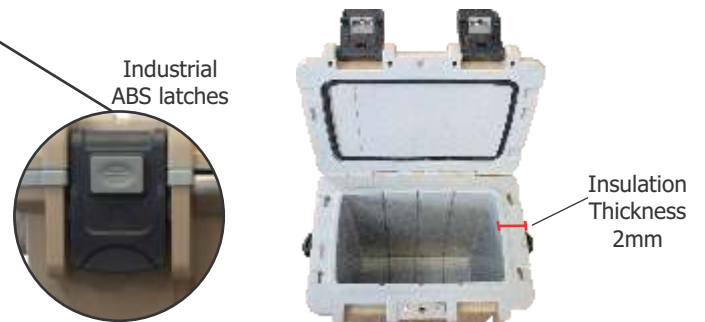



The Hard Case
Waterproof
Dustproof
Shockproof
Crushproof
Heavy Duty
Impact Proof

Safe for flying
(with built in air valve)
All cases equipped with
foam for maximum protection

All Cases come in Black with foam, are water & dust proof
and are made from Engineering Polypropylene Plastic



PLC1510
Hard Case
Box 225x185x115mm



PLC1520
Hard Case
Box 260x230x185mm



PLC1540
Hard Case For Laptop
12.5" inch laptop



PLC1570
Hard Case
Box 420x300x290mm



PLC1580
Hard Case
Box 460x350.3x170mm



PLC1590
Hard Case
Box 480x410x360mm

Hard Storage Cases

Hard Storage Cases

All Cases come in Black with foam, are water & dust proof and are made from Engineering Polypropylene Plastic



PLC1600
Hard Case
Box 570x360x265mm



PLC1610
Hard Case
Box 530x435x257mm



PLC1620
Hard Case
Box 630x485x310mm



PLC1630
Hard Case
Box 670x510x375mm



PLC1640
Hard Case
Box 865x565x430mm



PLC1650
Hard Case
Box 865x565x430mm



PLC1660
Hard Case
417 x 364 x 104mm



PLC1670
Hard Case
462 x 435 x 225mm



PLC1680
Hard Case Visible
w/Night Vision Goggles
460 x 230 x 180mm



PLC1690
Bow Case Visible
w/Pre-cubed breakout foam
1190 x 530 x 210mm

Hard Storage Cases

All Cases come in Black with foam, are water & dust proof and are made from Engineering Polypropylene Plastic



PLC1010
225 x 190 x 170mm OD



PLC1020
250 x 220 x 120mm OD



PLC1030
270 x 245 x 185mm OD



PLC1040
300 x 230 x 270mm OD



PLC1050
310 x 275 x 155mm OD



PLC1060
425 x 370 x 210mm OD



PLC1070
410 x 340 x 220mm OD



PLC1080
490 x 430 x 230mm OD



PLC1090
565 x 355 x 220mm OD



PLC1100
550 x 345 x 245mm OD
on Castors



PLC1110
865 x 565 x 430mm OD



PLC1120
1190 x 430 x 165mm OD



PLC1130
670 x 515 x 375mm OD



PLC1150
1387.5 x 393.7 x 152.4mm OD
Rifle Case



PLC1160
880 x 340 x 135mm OD
Shotgun Case



PLC1180
1252 x 294 x 129mm OD
Rifle Case



PLC1170
1030 x 330 x 150mm OD
Airsoft Gun Case

Hard Storage Cases

All Cases come in Black and are made from Engineering Polypropylene Plastic



PLC1043513
1040 x 350 x 130mm OD Rifle Case



PLC171305
190 x 170 x 60mm OD



PLC786639
847 x 722 x 432mm OD
Wheels



PLC744627
797 x 518 x 313mm OD

Storage Cases

Part No.	Description
TC AC01	Aluminium Case 210 X 170 X 65mm
TC AC02	Aluminium Case 250 X 160 X 65mm
TC AC03	Aluminium Case 310 X 170 X 65mm
TC AC04	Aluminium Case 320 X 240 X 65mm

Storage/Tool Cases

ALC001	3 in 1 Set of 3 cases : Aluminium Contents; Large 46 x 34 x 16.5cm Medium 43 x 29.5 x 13cm Small 39.8 x 25 x 10.2cm
ALC002	Case w/5 dividers - 42.5 x 28.5 x 12cm : Aluminium
ALC003	Case w/5 dividers and egg foam and pre-cut foam - 45.5 x 33 x 15.2cm : Aluminium
ALC010	Ammunition Case 40.6 x 25.4 x 22.2cm : Polyurethane camouflage
ALC011	Single Rifle Case 123.2 x 24.1 x 11.4cm : Aluminium silver dots surface
ALC013	Double Rifle Case 123.2 x 35.6 x 11.4cm : Aluminium silver dots surface
ALC014	Single Rifle case 123.2 x 24.1 x 11.4cm : Polyurethane camouflage
ALC015	Square Case with 4 pce tray 36.5 x 22.5 x 25cm : Aluminium
ALC016	Single Rifle case 140 x 24.1 x 11.4cm : Aluminium silver dots surface
ALC019	Double Rifle case 140 x 35.6 x 11.4cm : Polyurethane camouflage



ALC010



ALC011



ALC013



ALC015



ALC014



Backpacks

TC991087 : Tool & Laptop Backpack

- » Overall size - 46 x 20 x 45cm
- » Integrated padded compartments for notebooks & laptops
- » Heavy duty stitching with bar tracking on stress points
- » 26 storage options
- » Max. weight capacity 20kgs



TC991088 : Tool Backpack

- » Overall size - 65 x 20 x 40cm
- » Extra large main compartment
- » Separate padded compartment for notebooks
- » Heavy duty stitching with bar tracking on stress points
- » Max. weight capacity 20kgs
- » 20 storage options
- » With rubber base



Micro Storage Cases



- Box 169 x 123 x 50mm
Silicone liner with carabiner clip
- PLC18010** Colour: Blue
 - PLC18070** Colour: Yellow
 - PLC18130** Colour: Orange



- Box 198 x 130 x 53mm
Silicone liner with carabiner clip
- PLC18030** Colour: Blue
 - PLC18090** Colour: Yellow
 - PLC18150** Colour: Orange



- Box 247 x 143 x 66mm
Silicone liner with carabiner clip
- PLC18050** Colour: Blue
 - PLC18110** Colour: Yellow
 - PLC18170** Colour: Orange

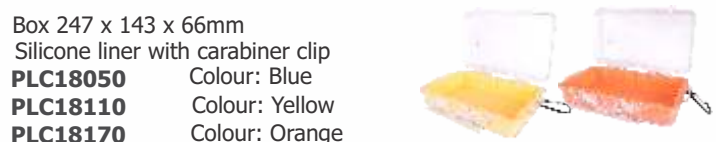

Ideal for all small storage purposes
Keep your valuables safe and dry
Inner Silicone liner for extra protection
Available in 3 Colours and 6 Sizes

- Outdoor use • Camping • Fishing • Workshop
- On site • Medical • Strong • Waterproof • Floats • Dustproof

- Box 198 x 100 x 60mm
Silicone liner with carabiner clip
- PLC18020** Colour: Blue
 - PLC18080** Colour: Yellow
 - PLC18140** Colour: Orange



- Box 199 x 130 x 79mm
Silicone liner with carabiner clip
- PLC18040** Colour: Blue
 - PLC18100** Colour: Yellow
 - PLC18160** Colour: Orange



- Box 248 x 160 x 65mm
Silicone liner with carabiner clip
- PLC18060** Colour: Blue
 - PLC18120** Colour: Yellow
 - PLC18180** Colour: Orange



Tool Belts, Pouches & Bags

Keeps your tools neat & in one place

Part No.	Description
TC991018	2 Pocket Tool Pouch Heavy-duty Nylon with belt clip, resists tearing
TC991052	5 Pocket Nylon Tool Pouch, 3 Main pockets for tools & nails, 2 Small pockets for accessories, 1 Steel hammer loop Padded construction belt for maximum comfort, designed to fit waist 38" - 48"
TC991051	7 Pocket Nylon Tool Pouch, 5 Main pockets for tools & nails, 2 Small pockets for accessories, padded construction belt for maximum comfort, designed to fit waist 38" - 48"
TC991055	8 Pocket Nylon Tool Pouch, 2 Main pockets for tools & nails, 6 Small pockets for accessories, 1 Steel hammer loop 1 Steel fence plier loop, padded construction belt for maximum comfort, designed to fit waist 32" - 42"
TC991012	22 Pocket Nylon Tool Pouch, 50mm Poly-web belt 1000mm adjustable with quick release buckle, 4 main pouches for utility tools and nails, measuring tape holder, 2 Strap loops
TC991260	22 Pockets, Medium Tool Bag, Size 400 x 210 x 310mm with shoulder strap
TC991265	25 Pockets, Small Tool Bag, Size 315 x 230 x 250mm with shoulder strap
TC991340	50 Pockets (incl. external pockets), Large Tool Bag, Size 495 x 265 x 340mm with shoulder strap



TC991018



TC991052



TC991051



TC991055



TC991012



TC991260



TC991265



TC991340



Leather Tool Belts



Part No. JT995022
2 Pocket/Pouch Leather Nail Bag
» with Nylon web belt
» Riveted for extra strength



Part No. JT995002
11 Pocket/Pouch Leather Tool Belt
» with Large nylon web belt
» Riveted for extra strength

TorkCraft Knee Pads

Part No. TC992008
TorkCraft Knee Pad



Gloves

Part No.	Description	Size		
All Purpose Work Glove				
GL02	All Purpose	M	For hand and power tool	• Comfortable fit
GL03	All Purpose	L	use, automotive & motor-	• Adjustable Strap Wrap
GL04	All Purpose	XL	cycle mechanics, package	• Good Wear Resistance
GL05	All Purpose	XXL	handling.	• Made from synthetic leather and spandex.
Synthetic Leather Palm Spandex Back				
GL10	Mechanics Glove	S	For hand tool use,	• Comfortable fit
GL11	Mechanics Glove	M	automotive & motor-cycle	• Breathable
GL12	Mechanics Glove	L	mechanics, gardening.	• Cowboy Cuff
GL13	Mechanics Glove	XL		• Made from synthetic leather and spandex.
GL14	Mechanics Glove	XXL		
GL15	Mechanics Glove	XXXL		
Synthetic Leather Re-inforced Palm - Red				
GL19	Utility Glove	XS	For hand tool & power	• Comfortable fit
GL20	Utility Glove	S	tool use, automotive,	• Adjustable Strap Wrap
GL21	Utility Glove	M	motorcycle mechanics,	• Good Grip
GL22	Utility Glove	L	racing and bike riding.	• Made from synthetic leather and spandex.
GL23	Utility Glove	XL		
GL24	Utility Glove	XXL		
GL25	Utility Glove	XXXL		
Synthetic Leather Palm Air Mesh Back - Blue				
GL29	Utility Glove	XS	For hand tool & power	• Comfortable fit
GL30	Utility Glove	S	tool use, automotive,	• Adjustable Wrist Strap
GL31	Utility Glove	M	motorcycle mechanics,	• Impact Protection
GL32	Utility Glove	L	racing and bike riding.	• Made from synthetic leather and mesh fabric.
GL33	Utility Glove	XL		
GL34	Utility Glove	XXL		
GL35	Utility Glove	XXXL		
Multi-purpose w/PU Palm Yellow				
GL50	Multi-purpose	S	For hand tool & power	• Comfortable fit
GL51	Multi-purpose	M	tool use, automotive,	• Cowboy Cuff
GL52	Multi-purpose	L	motorcycle mechanics.	• Breathable
GL53	Multi-purpose	XL		• Made from synthetic leather and spandex.
GL54	Multi-purpose	XXL		
Multi-purpose w/PU Palm Blue				
GL60	Multi-purpose	S	For hand tool & power	• Comfortable fit
GL61	Multi-purpose	M	tool use, automotive,	• Cowboy Cuff
GL62	Multi-purpose	L	motorcycle mechanics.	• Breathable
GL63	Multi-purpose	XL		• Made from synthetic leather and spandex.
GL64	Multi-purpose	XXL		
Leather Palm				
GL70	Utility Glove	S	For hand tool & power	• Comfortable fit
GL71	Utility Glove	M	tool use, automotive,	• Leather Palm
GL72	Utility Glove	L	motorcycle mechanics and	• Good Grip/Wear resistant
GL73	Utility Glove	XL	rigging.	• Cowboy Cuff
GL74	Utility Glove	XXL		• Made from synthetic leather and spandex.
ULTIMATE FEEL Work Smart Sport Glove				
GL80	Multi Purpose	XS	For hand tool & power	• Form Fit
GL81	Multi Purpose	S	tool use, automotive,	• Adjustable Strip Wrap
GL82	Multi Purpose	M	motorcycle mechanics,	• Touch Screen Able
GL83	Multi Purpose	L	racing and bike riding.	• Breathable/Good Grip
GL84	Multi Purpose	XL		• Made from synthetic leather and spandex.
GL85	Multi Purpose	XXL		

GL02 - GL05



GL10 - GL15



GL19 - GL25



GL29 - GL35



GL50 - GL54



GL60 - GL64



GL70 - GL74



GL80 - GL85



Touch panel

Ladies Slim Fit Gloves

Part No.	Description	Size		
GL41	Blue	XS	For gardening, general	• Comfortable fit
GL42	Blue	S	sports, household tasks,	• Slim Fit - Designed for smaller & ladies hands
GL43	Blue	M	DIY and pet care.	
GL44	Black	XS		• Fully Washable
GL45	Black	S		• Breathable
GL46	Black	M		• Made from synthetic leather and spandex.
GL47	Maroon	XS		
GL48	Maroon	S		
GL49	Maroon	M		



Multi Tools & Knives

Part No.	Description	w/Laser Engraved branding
KN3366A	Utility Knife Red with 5 Spare Blades (in blister)	
KN3486	Survival Knife Green with LED Light & Fire Starter (in double blister)	XKN3486
KN8126FI	MINI Multi-tool Silver with LED Light & Nylon Pouch (in blister)	XKN8126FI
KN8129S	Multi-tool Silver with LED Light & Nylon Pouch (in blister)	XKN8129S
KN8154	Multi-tool Red with Nylon Pouch (in blister)	XKN8154
KN8154A	Multi-tool Fishing Angler's Tool (in blister)	XKN8154A
KN8155	MINI Multi-tool Red with Nylon Pouch (in blister)	XKN8155
KN004	Foldable Utility Knife Red w/G10 material, handle & belt clip	



Knife Sharpener

Part No. TZ MR35
 Knife Sharpener with tungsten carbide edge
The No-Fuss Knife Sharpener
 » Sharpens dull knives in seconds
 » Hardness of 88 - 90 HRC
 » Protective finger guard
 » Non-slip rubber grip



Utility Blades

Part No.	Description	Qty
TCBB100-10	Utility Blade Solid 60 x 19 x 0.6mm	10
TCBB100-50	Utility Blade Solid 60 x 19 x 0.6mm	50
TCBB100-100	Utility Blade Solid 60 x 19 x 0.6mm	100

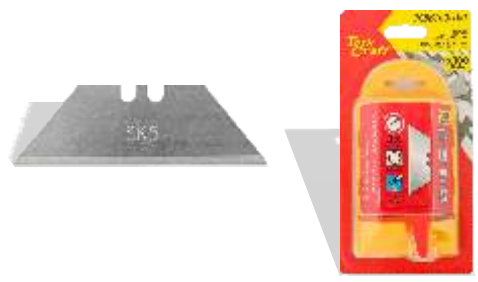

Ear Plugs

Part No.	Description
TCEP1000	Ear Plugs Bullet Shape 200/Box
TCEP1010	Ear Plugs 4pc Bullet 2pc Cylinder Carded
TCEP2000	Ear Plugs 1pc Polybag Corded Bullet Shape 100pairs/Box
TCEPD250	Ear Plug Dispenser c/w 250 pairs of ear plugs
TCEPD500	Ear Plug Dispenser c/w 500 pairs of ear plugs
TCEPD500-01	Ear Plug Refill pack 500 Pairs for TCEPD250 & 500
TCEP3000	Ear Muffs



Step 1
Squeeze ear plug

Step 2
Roll to form a crease-free cylinder

Step 3
Insert & hold in ear canal until plug expands.
After use, slowly remove plug with a twisting motion



Safety Eyewear

Part No.	Description	Application & Features
B5161	Clear in polybag	<ul style="list-style-type: none"> General purpose for indoor and outdoor use. Laboratory • Gardening • Wood Working • Construction • Industrial
B5162	Grey in polybag	<ul style="list-style-type: none"> For sunny to cloudy weather conditions. Outdoor • Sport • Cycling • Golf • Hiking • Construction • Industrial
B5163	Yellow in polybag	<ul style="list-style-type: none"> For foggy/hazy, low light conditions. Driving • Computers/Gaming • Cycling • Hiking • Shooting • Construction • Industrial
B5164	Clear Ergonomic Design	<ul style="list-style-type: none"> General purpose for indoor and outdoor use. Laboratory • Gardening • Wood Working • Construction • Industrial
		<ul style="list-style-type: none"> Ergonomic Design + Impact Resistant Stylish & outstanding protection. Non-slip cushion nosepiece provided comfort. Lightweight nylon frame with length adjustable templates. Wraparound design provides excellent protection. Durable polycarbonate lenses ensure impact resistance & UV 385 protection.
B5171	Clear Wraparound	General purpose: For indoor and outdoor use. For sunny to cloudy weather conditions. • Industrial • Construction • Gardening • Wood Working • Laboratory
B5172	Grey Wraparound	General purpose for indoor and outdoor use. For sunny to cloudy weather conditions. • Industrial • Construction • Cycling • Golf • Hiking • Outdoor • Sport
B5173	Yellow Wraparound	For foggy/hazy, low light conditions. • Industrial • Construction • Computers/Gaming • Driving • Cycling • Shooting • Sport
B5231	Clear	General purpose: For indoor and outdoor use. • Industrial • Construction • Gardening • Wood Working • Laboratory
B5232	Smoke	For sunny to cloudy weather conditions. • Industrial • Construction • Cycling • Driving • Water Sport • Hiking • Sport
B5233	Yellow	For foggy/hazy, low light conditions. • Industrial • Construction • Computers/Gaming • Driving • Cycling • Shooting • Sport
B5234	Silver Mirror	For sunny to cloudy weather and also glare (water) conditions. • Industrial • Construction • Cycling • Driving • Water Sport • Outdoor • Fishing
B5235	Red lens	For sunny to cloudy and bright (snow) conditions. • Industrial • Construction • Skiing • Driving • Cycling
B5311	Clear Welding style	For sunny to cloudy and bright (snow) conditions. • Industrial • Construction • Skiing • Driving • Cycling
B5531	Yellow mirror	For foggy/hazy, low light conditions. • Industrial • Construction • Computers/Gaming • Driving • Cycling • Shooting • Hiking
		<ul style="list-style-type: none"> Economical safety glasses feature lightweight stylish design with superior wraparound coverage. Padded temple ends reduce pressure. Polycarbonate lenses provide excellent protection from impact and harmful UV rays - 100% UV protection.
		
		
		
		
		
		
		
		

Dustmasks

Part No.	Description
TCDM1000	Dust Masks FFP1 - 20/Box
TCDM1001	Dust Masks FFP1 - 5/Pck
TCDM2000	Dust Masks FFP2 - 20/Box
TCDM2001	Dust Masks FFP2 - 5/Pck

Latex Free
Product is Homologation Approved
EN149:2001+A1:2009

- » Disposable Particulate Respirator
- » Filters out bacteria and viruses
- » Removes the suspended particulate
 - » Dust & pollen protection
 - » High filter efficiency
 - » Tight seal
 - » Comfortable use
 - » Latex-free head strap
- » Dolomite clogging resistant



TCDM1001



TCDM1000



TCDM2000



LED Torches

Rechargeable

NEW Design
Torch folds into L-shape
to stand up when 2
hands are required

3 Colour Light



Power Source: 18650 X1

TCFL110

SPECIFICATIONS

300 LUMENS	3h	96m	1m Impact resistant	water resistant IPX4
------------	----	-----	---------------------	----------------------

» Precision machined high-strength aircraft grade aluminium alloy case
» Anodized inside and out for improved corrosion resistance & durability
» Slip-resistant body design

Key Ring Size

RECHARGEABLE
Powerful + Bright
in your pocket



Power Source: 16340L X1

TCFL2010

SPECIFICATIONS

200 LUMENS	2h	90m	1m Impact resistant	water resistant IPX4
------------	----	-----	---------------------	----------------------



Power Source: AAA X3

TCFL060

SPECIFICATIONS

75 LUMENS	2.5h	50m	1m Impact resistant	water resistant
-----------	------	-----	---------------------	-----------------

With Custom Engraving
XTCFL020



Power Source: AA X3

TCFL020

SPECIFICATIONS

100 LUMENS	3 - 4h	100m	Strong Light Low Light Flashing	Tail Push Button Switch
------------	--------	------	---------------------------------	-------------------------

Pocket Size

With Custom Engraving
XTCFL030



Power Source: AA X1

TCFL030

SPECIFICATIONS

110 LUMENS	1 - 2h	50m	3 Mode Functions Turbo Mid Blinking	Tail Push Button Switch
------------	--------	-----	-------------------------------------	-------------------------



Power Source: AAA X3

TCFL070

SPECIFICATIONS

250 LUMENS	1.5h	160m	1.5m Impact resistant	water resistant
------------	------	------	-----------------------	-----------------



Power Source: AAA X3

TCFL130

SPECIFICATIONS

400 LUMENS	3h	100m	Adjustable Focus with Flood Spot	Tail Push Button Switch
------------	----	------	----------------------------------	-------------------------

Rechargeable

Long Life



Power Source: 18650 X1

TCFL090

SPECIFICATIONS

600 LUMENS	1.5h	250m	1.5m Impact resistant	water resistant
------------	------	------	-----------------------	-----------------

Power Source: D-CELL X3

TCFL100

SPECIFICATIONS

500 LUMENS	5h	250m	1.5m Impact resistant	water resistant
------------	----	------	-----------------------	-----------------



Power Source: 2 x CR123A, 1 x 18650

TCFL200

SPECIFICATIONS

500 LUMENS	3h	200m	1.5m Impact resistant	Waterproof and submersible 2m
------------	----	------	-----------------------	-------------------------------

Extra Long Life

Long Distance



Power Source: C X3

TCFL140

SPECIFICATIONS

600 LUMENS	8h	150m	Adjustable Focus with Flood Spot	Tail Push Button Switch
------------	----	------	----------------------------------	-------------------------

Power Source: 4 x CR123A, 2 x 18650

TCFL2030

SPECIFICATIONS

700 LUMENS	3h	300m	1.5m Impact resistant	Waterproof and submersible 2m
------------	----	------	-----------------------	-------------------------------



Power Source: AAA X2

TCFL150

SPECIFICATIONS

100 LUMENS	3h	50m	1m Impact resistant	Adjustable Focus
------------	----	-----	---------------------	------------------

High Mode: 400 LUMENS, 3 hrs
Low Mode: 40 LUMENS, 20 hrs

ANTI-ROLL BODY
POCKET CLIP
Tactical
BLUDGEON HEAD
TACTICAL TAIL SWITCH
DEEP KNURLING
SPOT LIGHT
WIDE ANGLE FLOOD LIGHT
Dual LED



Power Source: AA X4

TCFL400

SPECIFICATIONS

Intensity 6250cd	3h	185m	1m Impact resistant	water resistant IPX6
------------------	----	------	---------------------	----------------------



Power Source: AAA X3

TCFL200

SPECIFICATIONS

20 LUMENS	10m	1m Impact resistant	water resistant IPX4
-----------	-----	---------------------	----------------------

» 12 Pcs per Box
» Includes 3 AAA Batteries
» Long Life LED's
» Aluminium alloy construction

TCFL200-1
LED Aluminium Torch
Multi Coloured includes AAA TorkCraft batteries



■ **Alkaline**
 ■ **Silver Oxide**
 ■ **Lithium**
 ■ ■ **Zinc-Air**

AA Alkaline Battery

1.5 Volt Alk

Part No.	Pack Size
BATLR6-4S	4 Pack Shrink wrapped



AAA Alkaline Battery

1.5 Volt Alk

Part No.	Pack Size
BATLR03-4S	4 Pack Shrink wrapped



Alkaline D Battery

1.5 Volt Alk

Part No.	Pack Size
BATLR20-2S	4 Pack Shrink wrapped



3V Lithium Battery

3 Volt Li-ion

Part No.	Pack Size
BATCR123A-1P	1 per card
BATCR123A-2P	2 per card
BAT100512301	1 per card

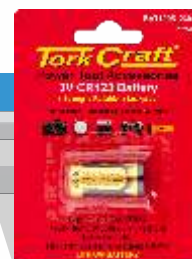

BAT100512301

9V Lithium Battery

9 Volt Li-ion

Part No.	Size
BATCR-V9-1P	1 per card



Hearing Aid Battery Zn 6x

Part No.	Pack Size
BATPR41	6 per card Brown
BATPR44	6 per card Blue
BATPR48	6 per card Orange
BATPR70	6 per card Yellow



Batteries & Chargers

Alkaline Coin Battery

1.5 Volt Alk

Part No.	Size	MOQ
BATLR41-5	5 per card	20
BATLR43-5	5 per card	20
BATLR44-5	5 per card	20
BATLR521-5	5 per card	20
BATLR54-5	5 per card	20
BATLR55-5	5 per card	20
BATLR621-5	5 per card	20
BATLR66-5	5 per card	20
BATLR721-5	5 per card	20
BATLR726-5	5 per card	20
BATLR754-5	5 per card	20
BATLR921-5	5 per card	20
BATLR927-5	5 per card	20
BATLR936-5	5 per card	20

NEW PRODUCT



Silver Oxide Coin Battery

1.5 Volt SIL-ox

Part No.	Size	MOQ
BATSR41-5	5 per card	20
BATSR44-5	5 per card	20
BATSR54-5	5 per card	20
BATSR60-5	5 per card	20
BATSR66-5	5 per card	20

NEW PRODUCT



Lithium Coin Battery

3 Volt Li-ion

Part No.	Size	MOQ
BATCR1216-5	5 per card	20
BATCR1220-5	5 per card	20
BATCR1225-5	5 per card	20
BATCR1616-5	5 per card	20
BATCR1620-5	5 per card	20
BATCR1632-5	5 per card	20
BATCR2016-5	5 per card	20
BATCR2025-5	5 per card	20
BATCR2032-5	5 per card	20
BATCR2430-5	5 per card	20

NEW PRODUCT



Rechargeable Battery & Charger

Part No.	Description
BAT100518651	Battery Lithium 2200MAH Rechargeable Carded 1Pc
TCBC18650	Battery Charger USB 18650Li-Ion AVG, 800mAh v/1A



TCBC18650



Coin Battery Display MER008
2 in 1 for Counter & Pegboard

Magnifying LED Rechargeable Desk Lamp

TCML001	Magnifying LED USB Rechargeable Desk Lamp
TCML001-01	USB Cable for TCML001
TCML001-02	Replacement Lens for TCML001
TCML001-03	Replacement LED Light for TCML001

LED magnifying lamp for general home use & precision work

- » 6 x LED Lights / 60 Lumens
- » 25,000 Hours LED life time
- » Two ON/OFF switches;
 - 1 x Manual at back of base
 - 1 x Touch control switch top front
- » 3x & 8x Magnifying capabilities
- » Base & desk clamp fitting;
 - Desk clamp fitting connects to the base
- » Base size : 135 x 180 x 23mm
- » Lens diameter : 110mm
- » Convenient
- » 400mAH rechargeable lithium battery
- » No automatic off timer



3x & 8x

Rechargeable



Handheld LED Magnifier

TCML002	Handheld LED Magnifier
---------	------------------------

LED Handheld folding Magnifier for general home use & precision work

- » 60 Lumens
- » ON/OFF switch on top
- » 3x, 8x & 11x Magnifying capabilities
- » Desk standing
- » Lens diameter : 75mm
- » USB Rechargeable battery
- » No automatic off timer

3x
8x &
11x

NEW
PRODUCT

Built-in
Light



Handheld Magnifier



Part No. TCML050
50mm Magnifier - 6x Magnification

Part No. TCML075
75mm Magnifier - 5x Magnification



LED Light Switch

Part No. TCFL3010

Led Light Switch Style Wall Lamp w/Magnetic Wall Fitting 200 Lumens

- » Batteries **not included**
- » Keyhole mounting hardware included (w/screws & plugs)
- » Hook & loop fixing strip included

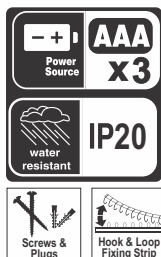

Part No. TCFL3012

12 Pce Box Display with Led Light Switch Style Wall Lamp w/Magnetic Wall Fitting 200 Lumens

Part No. TCFL3012-1

Led Light Switch Style Wall Lamp w/Magnetic Wall Fitting 200 Lumens BULK replacement for Display Box Use BATLR03-4S AAA Batteries

Motion Activated Ceiling Trilight

Part No. TCFL500

Motion Activated Ceiling Trilight
Arrive home in a fully lit garage

- » 3000 Lumens
- » 50,000 Hours
- » Daylight White LED
- » Quick installation, no tools required
- » Screws into most light sockets
- » Motion Sensor
- » Adjustable aluminium heads
- » Convenient
- » Safe & secure
- » Energy saving



3000 Lumens
Multi Directional Motion Sensor

Cast Aluminum Heatsink Heads



Standard Light Bulb Screw

Stainless Steel Braided Cable

LED Module

Motion Sensor On/Off Switch

Safe-T-Join Cable Joint

Safe Join

Part No. Description

TCCJ001	Electrical Cable Joint Mould - Suitable for cable sizes up to 1.5mm, 2 ripcord cables
TCCJ002	Electrical Cable Joint Mould - Suitable for cable sizes up to 0.5mm & 2.0mm, 2 & 3 ripcord cables
TCCJ003	Electrical Cable Joint Mould - Suitable for cable sizes up to 0.5mm & 2.5mm, 2 & 3 ripcord cables

Joining your cables & securing your home

- » Easy, safe & secure moulding of standard electrical connections 220V
- » Tools required: Wire stripper / Glue gun / Glue sticks / Clamp
- » Heat shrink tubes included



GO ONLINE TO www.torkcraft.com to view instruction video



Phone Protection Pouch

IPX8

waterproof

dust resistant

dust resistant

Part No. TC991090

3Pce Phone Protection Pouch Set
 Contents;

- » 1 x Large Pouch - 180 x 100mm
- » 1 x Medium Pouch - 160 x 100mm
- » 1 x Lanyard w/Carabiner Clip

Features :

Dustproof, Waterproof, Easy Access, Touch & listen friendly, Anti-drop, Pocket size



Camping Lamp

Part No. TCFL300

Led Bulb Style Camping Lamp
 60 Lumens

	20 m	High Mode	Med Mode	Flashing
	AAA X3	60 LUMENS	25 LUMENS	60 LUMENS
	IP20	3-4 hrs	8 hrs	3-4 hrs



- » Ideal for caving, camping & outdoor adventures
- » Comes with hanging hook
- Use BATLR03-4S AAA Batteries



Bicycle Repair Stand

Part No.	Description
TC BS001	Bicycle Repair Work & Storage Stand
TC BS001-01	Spare Wing Nut for TC BS001
TC BS001-02	Spare Plastic Quick Release Lever for TC BS001
TC BS001-03	Spare Plastic Corner Cap for TC BS001
TC BS001-04	Spare Plastic Tool Tray for TC BS001

TorkCraft's bicycle repair stand is packed with features you would expect to find in a stand priced three times more expensive. When folded up it can neatly store away anywhere, even in a small car boot, so you are even able to take it with you to a race. It has a work height adjustment between 110cm and 190cm so is perfect for kids or even the tallest of men. A stable design with 4 support legs allows a maximum weight of up to 30kg's. The practical fast clamping and adjusting design allows for both standard and oversize tubing so virtually any bike frame will fit the repair stand. There is also a magnetic parts tray which keeps all your little pieces and tools in place whilst you work on your bike. It also features a unique handle bar stabiliser to keep your front wheel steady and out of the way whilst working.



Bicycle Roof Storage Rack

TCBS020

Bicycle Roof Storage Space Saver

- » Steel construction bicycle lift with unique pulley locking mechanism system
- » Fast and easy ceiling mounting, for ceiling heights up to 4m
- » For use in garages and basements
- » 46ft. PP rope and mounting hardware included
- » With rubber coated fixing hooks to prevent the bicycle from scratches
- » Saves space and protects tyres
- » Loading capacity 20kg



BICYCLE LIFT



Bicycle Hook Wall Mounted

TCBS030

Bicycle Hook - Wall Mounted

FEATURES

- » Steel construction bicycle hook
- » Rack powder coated to prevent scratches
- » Fast and easy wall mounting with 2 screws (screws included)
- » For use in garages and basements
- » Saves space and protects tyres
- » Loading capacity 20kg



Mini Tool Kits

Fits all standard mini tools

Part No.	Description
TC08070	70 Pce Mini Rotary Accessories Set
TC08872	72 Pce Mini Rotary Tool & Accessories Set w/Flexible Shaft
TC08051	180 Pce Mini Rotary Accessories Set
TC08172	172 Pce Mini Rotary Tool & Accessories Set
TC08208	208 Pce Mini Rotary Accessories Set
TC08245	245 Pce Mini Rotary Tool & Accessories Set



TC08051



TC08172



TC08208



TC08070



TC08245



TC08872



TCMT001

Specifications:

Rated Voltage : 220V

Rated Output Power : 170W

No Load Speed : 8,000 - 35,000rpm

Collet Chuck Capacity : 1.6mm - 3.2mm

Collet Sizes Included : 1.6mm/2.3mm/3.2mm

NB. Colour of machine may vary

TCMT006

Cordless Mini Grinder with 11 Pce Accessory Set

Applications: Sanding, Cutting, Grinding, Cleaning, Polishing & Engraving

» USB Cable included

» Battery Included - (1634) 3,7V 600mAH Li-ion

» Battery charging indicator

» 2 Hour charge time

» Free run time 100 minutes

Accessories included;

» 2 x Sanding Sleeves

» 2 x Grinding Wheels

» 2 x Diamond Points

» 1 x Engraving Point

» 1 x Rubber Sanding Drum

» 1 x Nylon Brush

» 2 x Collets 2.4 & 3.2mm

NB. Colour of machine may vary

2hrs

USB

3.7V

Rechargeable



TCMT007

Cordless Mini Rotary Tool with 5 Pce Accessory Set

Applications: Small scale projects such as Carving & Engraving

» Battery operated - 2 x AAA batteries Included

» Light weight & slim design

Accessories included;

» 2 x Grinding stones

» 3 x Carving tips

NB. Colour of machine may vary

Use BATLR03-4S AAA Batteries



FREE! Batteries

13 000 MAX RPM

Part No.	Description
TCMT001	Mini Tool 220V 170W Rotary
TCMT001-2-3-1	Collet 3.2mm for TCMT001
TCMT001-2-3-2	Collet 2.3mm for TCMT001
TCMT001-2-3-3	Collet 1.6mm for TCMT001
TCMT001DC	Drill chuck 0 - 3.2mm for TCMT001
TCMT001FS	Flexible shaft for TCMT001
TCMT001SS	Mini Rotary Tool Hanging Stand - Telescopic Hanging Hook with desk clamp
TCMT001DA	Mini Rotary Tool Attachment for TCMT001 w/Depth adjustment to 19mm
TCMT006	Cordless Mini Grinder w/11 Pce Set



TCMT001FS



TCMT001DA



TCMT001SS



NEW PRODUCT



TC08022
22 Pce Cleaning & Polishing Set



TC08034
34 Pce Sanding & Grinding Set



TC08050
50 Pce Cutting & Carving Set



TC08052
52 Pce General Purpose Set



TC08072
72 Pce Cut-Off Wheel Set

Electric Engraver 13W

Part No. Description

TCMT005 TorkCraft Electric Engraver 13W

TCMT005-1 Repl. tips for TCMT005

Includes;

» 1 x Tungsten Carbide Tip

» 1 x Letter & Number Stencil

» 1 x Shape & Symbol Stencil

Specifications:

Rated Voltage : 220V

Rated Output Power : 13W

No Load Speed : 7200rpm

Stroke Adjustment : 5 x Mode

- » Ideal for precision engraving in metal, glass, wood, plastic, ceramic and leather
- » Stroke adjustment dial for fine lines or deep grooves
- » Soft coated housing provides better comfort and handling
- » Protect your valuables with engraving for easy identification



NB. Colour of machine may vary



Mini Tool Accessories Carded

Part No. Description

TC08301	Mini High Speed Cutter 6.4mm Ball 3.2mm Shank
TC08302	Mini High Speed Cutter 7.9mm Ball 3.2mm Shank
TC08303	Mini High Speed Cutter 7.9mm Cylindrical 3.2mm Shank
TC08304	Mini High Speed Cutter 6.4mm Reverse Taper 3.2mm Shank
TC08305	Mini High Speed Cutter 6.4mm Cone 3.2mm Shank
TC08306	Mini High Speed Cutter 3.2mm Countersink 3.2mm Shank
TC08307	Mini High Speed Cutter 6.4mm Flame 3.2mm Shank
TC08308	Mini High Speed Cutter 7.9mm Oval 3.2mm Shank
TC08309	Mini High Speed Cutter 6.4mm Point 3.2mm Shank
TC08310	Mini High Speed Cutter 6.4mm Round Point 3.2mm Shank
TC08311	Mini High Speed Cutter 7.9mm Flame 3.2mm Shank
TC08312	Mini High Speed Cutter 3.2mm Flame 3.2mm Shank
TC08313	Mini High Speed Cutter 3.2mm Ball 3.2mm Shank
TC08314	Mini High Speed Cutter 4.8mm Ball 3.2mm Shank
TC08315	Mini High Speed Cutter 3.2mm Reverse Taper 3.2mm Shank
TC08316	Mini High Speed Cutter 3.2mm Cylindrical 3.2mm Shank
TC08317	Mini High Speed Cutter 5.6mm Cylindrical 3.2mm Shank
TC08318	Mini Engraving Cutter 1.6mm Ball 2.4mm Shank



Part No. Description

TC08320	Mini Engraving Cutter 2.4mm Ball 2.4mm Shank
TC08321	Mini Engraving Cutter 1.6mm Ball 2.4mm Shank
TC08322	Mini Engraving Cutter 2.0mm Reverse Taper 2.4mm Shank
TC08323	Mini Engraving Cutter 2.4mm Reverse Taper 2.4mm Shank
TC08324	Mini Engraving Cutter 0.8mm Cylindrical 2.4mm Shank
TC08325	Mini Engraving Cutter 1.2mm Cylindrical 2.4mm Shank
TC08326	Mini Engraving Cutter 2.0mm Cylindrical 3.2mm Shank



Part No. Description

TC08327	Mini Diamond Point 2.0mm Ball 2.4mm Shank
TC08328	Mini Diamond Point 4.4mm Ball 2.4mm Shank
TC08329	Mini Diamond Point 9.5mm Reverse Taper 2.4mm Shank
TC08330	Mini Diamond Point 6.7mm Disc 2.4mm Shank
TC08331	Mini Diamond Point 2.4mm Cylindrical 2.4mm Shank
TC08332	Mini Diamond Point 4.8mm Cylindrical 3.2mm Shank
TC08333	Mini Diamond Point 0.9mm Point 2.4mm Shank
TC08334	Mini Diamond Point 1.2mm Point 2.4mm Shank



Part No. Description

TC08335	Mini Tungsten Carbide Cutter 3.2mm Cylindrical	3.2mm Shank
TC08336	Mini Tungsten Carbide Cutter 2.4mm Cylindrical	3.2mm Shank
TC08337	Mini Tungsten Carbide Cutter 3.2mm Cylindrical	3.2mm Shank
TC08338	Mini Tungsten Carbide Cutter 3.2mm Round Point	3.2mm Shank
TC08339	Mini Tungsten Carbide Cutter 3.2mm Ball	3.2mm Shank
TC08340	Mini Tungsten Carbide Cutter 3.2mm Countersink	3.2mm Shank
TC08342	Mini Tungsten Carbide Cutter 3.2mm Cone	3.2mm Shank
TC08343	Mini Tungsten Carbide Cutter 3.2mm Flame	3.2mm Shank



Mini Tool Accessories Carded

Part No. Description

TC08344	Mini Rubber Polishing Point 6.4mm Cylindrical 2.4mm Shank
TC08345	Mini Rubber Polishing Point 6.4mm Bullet 2.4mm Shank
TC08346	Mini Rubber Polishing Point 6.4mm Sharp Point 2.4mm Shank



Part No. Description

TC08347	Mini Felt Polishing Point 12.7mm x 6mm Wheel
TC08348	Mini Felt Polishing Point 9.5mm x 20mm Bullet
TC08349	Mini Felt Polishing Point 25.4mm x 8mm Wheel
TC08350	Mini Emery Polishing Point 22mm x 3.0mm Wheel
TC08351	Mini Felt Polishing Point 12.7mm Cylindrical 3.2mm Shank



Part No. Description

TC08352	Mini Screw Mandrel Reinforced 3.2mm Shank
TC08353	Mini Pyramidal Mandrel 3.2mm Shank
TC08441	Mini Screw Mandrel Reinforced 6.35 x 50 x 3.2mm



Part No. Description

Tc08355	Mini Nylon Bristle Brush 22.2mm Wheel	3.2mm Shank
TC08356	Mini Nylon Bristle Brush 12.7mm Cup	3.2mm Shank
TC08357	Mini Nylon Bristle Brush 3.2mm End	3.2mm Shank
TC08358	Mini Carbon Steel Brush 22.2mm Wheel	3.2mm Shank
TC08359	Mini Carbon Steel Brush 12.7mm Cup	3.2mm Shank
TC08360	Mini Carbon Steel Brush 4.2mm End	3.2mm Shank
TC08364	Mini Brass Brush 22.2mm Wheel	3.2mm Shank
TC08365	Mini Brass Brush 12.7mm Cup	3.2mm Shank
TC08366	Mini Brass Brush 4.2mm End	3.2mm Shank
TC08367	Mini Polishing Compound for Metals & Plastics	
TC08368	Mini Cut-off Wheel Reinforced 31.8mm x 1.1mm	
TC08369	Mini Cut-off Wheel Extra Large 38.1mm x 1.2mm	
TC08370	Mini Cut-off Wheel 24mm x 0.6mm	
TC08371	Mini Cut-off Wheel Reinforced 24mm x 0.6mm	
TC08372	Mini Cut-off Wheel Reinforced 31.8mm x 1.2mm	
TCW006-4	5 Pce Stainless Steel Mini Brush Set 3.2mm Shaft - Ass. shapes	
TCW006-5	5 Pce Brass Mini Brush Set 3.2mm Shaft - Assorted shapes	
TCW006-6	5 Pce Nylon Mini Brush Set 3.2mm Shaft - Assorted shapes	



Part No. Description

TC08373	Mini Rip & Cross Cut Blade 31.8mm x 0.6mm x 9.2mm
TC08374	Mini Multi-purpose Drill Bit 3.2mm x 3.2mm Shank
TC08375	Mini Wall Tile Cutting Bit 3.2mm x 3.2mm Shank
TC08376	Mini Grout Removal Bit 1.6mm x 2.4mm Shank
TC08377	Mini Grout Removal Bit 3.2mm x 3.2mm Shank



Part No. Description

TC08378	Mini HSS Drill Bit 0.8mm
TC08379	Mini HSS Drill Bit 1.2mm
TC08380	Mini HSS Drill Bit 3.2mm



Part No. Description

TC08381	Mini Router Bit 9.5mm Piloted Beading 3.2mm Shank
TC08382	Mini Router Bit 9.5mm Piloted Rabbeting 3.2mm Shank
TC08383	Mini Router Bit 6. mm Core Box 3.2mm Shank
TC08384	Mini Router Bit 9.5mm Piloted Cove 3.2mm Shank
TC08385	Mini Router Bit 6.4mm V-Groove 3.2mm Shank
TC08386	Mini Router Bit 3.2mm Straight 3.2mm Shank
TC08387	Mini Router Bit 4.8mm Straight 3.2mm Shank
TC08388	Mini Router Bit 6.4mm Straight 3.2mm Shank
TC08389	Mini Router Bit 7.9mm Keyhole 3.2mm Shank



Part No. Description

TC08390	Mini Quick Change Collet Kit 0.8, 1.6, 2.4, 3.2mm
TC08391	Mini Replacement Collet 0.8mm
TC08392	Mini Replacement Collet 1.6mm
TC08393	Mini Replacement Collet 3.2mm
TC08394	Mini Multi Chuck for 0.8 - 3.2mm Shank
TC08395	Mini Collet Wrench



Mini Tool Accessories Carded

Part No. Description

TC08396	Mini Grinding Stone 7.1mm Round Point 3.2mm Shank
TC08397	Mini Grinding Stone 3.2mm Bullet 3.2mm Shank
TC08398	Mini Grinding Stone 3.2mm Cylindrical 3.2mm Shank
TC08399	Mini Grinding Stone 6.0mm Cone 3.2mm Shank
TC08400	Mini Grinding Stone 19.8mm Wheel 3.2mm Shank
TC08401	Mini Grinding Stone 8.2mm Wheel 3.2mm Shank
TC08402	Mini Grinding Stone 10.0mm Wheel 3.2mm Shank
TC08403	Mini Grinding Stone 10.0mm Cylindrical 3.2mm Shank
TC08404	Mini Grinding Stone 9.5mm Cylindrical 3.2mm Shank
TC08405	Mini Grinding Stone 13.5mm Cone 3.2mm Shank
TC08406	Mini Grinding Stone 6.4mm Bullet 3.2mm Shank
TC08407	Mini Grinding Stone 9.5mm Bullet 3.2mm Shank
TC08408	Mini Grinding Stone 6.4mm Cone 3.2mm Shank
TC08409	Mini Grinding Stone 10.0mm Disc 3.2mm Shank
TC08410	Mini Grinding Stone 5.5mm Cone 3.2mm Shank
TC08411	Mini Grinding Stone 6.4mm Cylindrical/Cone 3.2mm Shank
TC08412	Mini Grinding Stone 9.5mm Ball 3.2mm Shank
TC08413	Mini Grinding Stone 14.7mm Cylindrical 3.2mm Shank
TC08414	Mini Grinding Stone 25.4mm Wheel 3.2mm Shank
TC08415	Mini Grinding Stone 4.0mm Cylindrical 3.2mm Shank
TC08416	Mini Grinding Wheel 20.0mm



Part No. Description

TC08417	Mini Chain Saw Sharpening Stone 4.0mm x 3.2mm Shank
TC08418	Mini Chain Saw Sharpening Stone 4.8mm x 3.2mm Shank
TC08419	Mini Chain Saw Sharpening Stone 5.6mm x 3.2mm Shank



Part No. Description

TC08420	Mini Abrasive Wheel 20.0mm x 3.2mm Shank
TC08421	Mini Abrasive Point 12.7mm Cone 3.2mm Shank
TC08422	Mini Abrasive Point 6.4mm Round Point 3.2mm Shank
TC08423	Mini Abrasive Point 7.0mm Cylindrical 3.2mm Shank



Part No. Description

TC08424	Mini Dressing Stone 25.4mm x 9.5mm
TC08425	Mini Sanding Drum 6.4mm x 3.2mm Shank
TC08426	Mini Sanding Drum 12.7mm x 3.2mm Shank
TC08427	Mini Sanding Sleeve 6.4mm 60G
TC08428	Mini Sanding Sleeve 6.4mm 120G
TC08429	Mini Sanding Sleeve 12.7mm 60G
TC08430	Mini Sanding Sleeve 12.7mm 120G
TC08431	Mini Sanding Sleeve 12.7mm 240G
TC08432	Mini Sanding Sleeve 6.4mm 240G
TC08433	Mini Carbide Sanding Drum & Band 12.7mm x 3.2mm Shank
TC08434	Mini Sanding Disc 19.1mm 180G
TC08435	Mini Sanding Disc 19.1mm 220G
TC08436	Mini Sanding Disc 19.1mm 240G
TC08437	Mini Flap Wheel 29.5 x 10 x 3.2mm Shank 120G
TC08438	Mini Flap Wheel 29.5 x 5 x 3.2mm Shank 80G
TC08439	Mini Flap Wheel 29.5 x 10 x 3.2mm Shank 80G
TC08440	Mini Flap Wheel 29.5 x 5 x 3.2mm Shank 120G



Part No. Description

TC08442	Mini Diamond Saw Blade 22mm
TC08443	Mini Diamond Saw Blade 30mm
TC08444	Mini Diamond Saw Blade 40mm
TC08445	Cotton Yarn Disc 24mm Shank 2.35mm

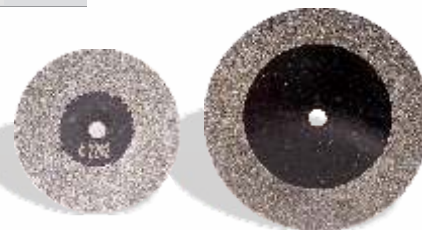

Impact Sockets - 1/2" Drive Standard + Long Series

INDUSTRIAL



TCIM20008-
TCIM20010



TCIM20011-
TCIM20014



TCIM20015-
TCIM20016



TCIM20017-
TCIM20021



TCIM20022-
TCIM20025



TCIM20026-
TCIM20032

1/2"

Part No.	Size	Description
TCIM20008	8mm	1/2" Drive 6pt Impact Socket
TCIM20009	9mm	1/2" Drive 6pt Impact Socket
TCIM20010	10mm	1/2" Drive 6pt Impact Socket
TCIM20011	11mm	1/2" Drive 6pt Impact Socket
TCIM20012	12mm	1/2" Drive 6pt Impact Socket
TCIM20013	13mm	1/2" Drive 6pt Impact Socket
TCIM20014	14mm	1/2" Drive 6pt Impact Socket
TCIM20015	15mm	1/2" Drive 6pt Impact Socket
TCIM20016	16mm	1/2" Drive 6pt Impact Socket
TCIM20017	17mm	1/2" Drive 6pt Impact Socket
TCIM20018	18mm	1/2" Drive 6pt Impact Socket
TCIM20019	19mm	1/2" Drive 6pt Impact Socket
TCIM20020	20mm	1/2" Drive 6pt Impact Socket

Part No.	Size	Description
TCIM20021	21mm	1/2" Drive 6pt Impact Socket
TCIM20022	22mm	1/2" Drive 6pt Impact Socket
TCIM20023	23mm	1/2" Drive 6pt Impact Socket
TCIM20024	24mm	1/2" Drive 6pt Impact Socket
TCIM20025	25mm	1/2" Drive 6pt Impact Socket
TCIM20026	26mm	1/2" Drive 6pt Impact Socket
TCIM20027	27mm	1/2" Drive 6pt Impact Socket
TCIM20028	28mm	1/2" Drive 6pt Impact Socket
TCIM20029	29mm	1/2" Drive 6pt Impact Socket
TCIM20030	30mm	1/2" Drive 6pt Impact Socket
TCIM20031	31mm	1/2" Drive 6pt Impact Socket
TCIM20032	32mm	1/2" Drive 6pt Impact Socket



TCIM21010-
TCIM21014



TCIM21015-
TCIM21021



TCIM21022-
TCIM21026



TCIM21027-
TCIM21032

1/2"

Part No.	Size	Description
TCIM21010	10mm	1/2" Drive 6pt deep Impact Socket
TCIM21011	11mm	1/2" Drive 6pt deep Impact Socket
TCIM21012	12mm	1/2" Drive 6pt deep Impact Socket
TCIM21013	13mm	1/2" Drive 6pt deep Impact Socket
TCIM21014	14mm	1/2" Drive 6pt deep Impact Socket
TCIM21015	15mm	1/2" Drive 6pt deep Impact Socket
TCIM21016	16mm	1/2" Drive 6pt deep Impact Socket
TCIM21017	17mm	1/2" Drive 6pt deep Impact Socket
TCIM21018	18mm	1/2" Drive 6pt deep Impact Socket
TCIM21019	19mm	1/2" Drive 6pt deep Impact Socket
TCIM21020	20mm	1/2" Drive 6pt deep Impact Socket

Part No.	Size	Description
TCIM21021	21mm	1/2" Drive 6 pt deep Impact Socket
TCIM21022	22mm	1/2" Drive 6 pt deep Impact Socket
TCIM21023	23mm	1/2" Drive 6 pt deep Impact Socket
TCIM21024	24mm	1/2" Drive 6 pt deep Impact Socket
TCIM21025	25mm	1/2" Drive 6 pt deep Impact Socket
TCIM21026	26mm	1/2" Drive 6 pt deep Impact Socket
TCIM21027	27mm	1/2" Drive 6 pt deep Impact Socket
TCIM21028	28mm	1/2" Drive 6 pt deep Impact Socket
TCIM21029	29mm	1/2" Drive 6 pt deep Impact Socket
TCIM21030	30mm	1/2" Drive 6 pt deep Impact Socket
TCIM21032	32mm	1/2" Drive 6 pt deep Impact Socket

Part No.	Description
TCIM29010	10PC 1/2" (10.11.13.14.17.19.21.22.24.27)
TCIM29015	15PC 1/2"(10 - 27 + 2 X Adaptors 3/8x1/2 & 1/2x3/8)

Part No.	Size	Description
TCIM22004	H4	1/2" Drive Impact Bit Socket (43mml)
TCIM22005	H5	1/2" Drive Impact Bit Socket (43mml)
TCIM22006	H6	1/2" Drive Impact Bit Socket (43mml)
TCIM22007	H7	1/2" Drive Impact Bit Socket (43mml)
TCIM22008	H8	1/2" Drive Impact Bit Socket (43mml)
TCIM22010	H10	1/2" Drive Impact Bit Socket (43mml)
TCIM22012	H12	1/2" Drive Impact Bit Socket (43mml)
TCIM22014	H14	1/2" Drive Impact Bit Socket (43mml)
TCIM22017	H17	1/2" Drive Impact Bit Socket (43mml)
TCIM22019	H19	1/2" Drive Impact Bit Socket (43mml)



TCIM29010



TCIM29015



TCIM22004-TCIM22019

Impact Sockets - 3/4" Drive Standard + Long Series

INDUSTRIAL



TCIM30017-
TCIM30022

TCIM30023-
TCIM30024

TCIM30025-
TCIM30028

TCIM30029-
TCIM30030

TCIM30031-
TCIM30043

TCIM30044-
TCIM30053

TCIM30054-
TCIM30070

Part No.	Size	Description
TCIM30017	17mm	3/4" Drive 6pt Impact Socket
TCIM30018	18mm	3/4" Drive 6pt Impact Socket
TCIM30019	19mm	3/4" Drive 6pt Impact Socket
TCIM30020	20mm	3/4" Drive 6pt Impact Socket
TCIM30021	21mm	3/4" Drive 6pt Impact Socket
TCIM30022	22mm	3/4" Drive 6pt Impact Socket
TCIM30023	23mm	3/4" Drive 6pt Impact Socket
TCIM30024	24mm	3/4" Drive 6pt Impact Socket
TCIM30025	25mm	3/4" Drive 6pt Impact Socket
TCIM30026	26mm	3/4" Drive 6pt Impact Socket
TCIM30027	27mm	3/4" Drive 6pt Impact Socket
TCIM30028	28mm	3/4" Drive 6pt Impact Socket
TCIM30029	29mm	3/4" Drive 6pt Impact Socket
TCIM30030	30mm	3/4" Drive 6pt Impact Socket
TCIM30031	31mm	3/4" Drive 6pt Impact Socket
TCIM30032	32mm	3/4" Drive 6pt Impact Socket
TCIM30033	33mm	3/4" Drive 6pt Impact Socket
TCIM30034	34mm	3/4" Drive 6pt Impact Socket
TCIM30035	35mm	3/4" Drive 6pt Impact Socket
TCIM30036	36mm	3/4" Drive 6pt Impact Socket
TCIM30037	37mm	3/4" Drive 6pt Impact Socket
TCIM30038	38mm	3/4" Drive 6pt Impact Socket
TCIM30039	39mm	3/4" Drive 6pt Impact Socket

Part No.	Size	Description
TCIM30040	40mm	3/4" Drive 6pt Impact Socket
TCIM30041	41mm	3/4" Drive 6pt Impact Socket
TCIM30042	42mm	3/4" Drive 6pt Impact Socket
TCIM30043	43mm	3/4" Drive 6pt Impact Socket
TCIM30044	44mm	3/4" Drive 6pt Impact Socket
TCIM30045	45mm	3/4" Drive 6pt Impact Socket
TCIM30046	46mm	3/4" Drive 6pt Impact Socket
TCIM30047	47mm	3/4" Drive 6pt Impact Socket
TCIM30048	48mm	3/4" Drive 6pt Impact Socket
TCIM30049	49mm	3/4" Drive 6pt Impact Socket
TCIM30050	50mm	3/4" Drive 6pt Impact Socket
TCIM30051	51mm	3/4" Drive 6pt Impact Socket
TCIM30052	52mm	3/4" Drive 6pt Impact Socket
TCIM30053	53mm	3/4" Drive 6pt Impact Socket
TCIM30054	54mm	3/4" Drive 6pt Impact Socket
TCIM30055	55mm	3/4" Drive 6pt Impact Socket
TCIM30056	56mm	3/4" Drive 6pt Impact Socket
TCIM30057	57mm	3/4" Drive 6pt Impact Socket
TCIM30058	58mm	3/4" Drive 6pt Impact Socket
TCIM30059	59mm	3/4" Drive 6pt Impact Socket
TCIM30065	65mm	3/4" Drive 6pt Impact Socket
TCIM30070	70mm	3/4" Drive 6pt Impact Socket



TCIM31017-
TCIM31022

TCIM31023-
TCIM31027

TCIM31028-
TCIM31033

TCIM31034-
TCIM31041

TCIM31042-
TCIM31055

Part No.	Size	Description
TCIM31017	17mm	3/4" Drive 6pt Deep Impact Socket
TCIM31018	18mm	3/4" Drive 6pt Deep Impact Socket
TCIM31019	19mm	3/4" Drive 6pt Deep Impact Socket
TCIM31020	20mm	3/4" Drive 6pt Deep Impact Socket
TCIM31021	21mm	3/4" Drive 6pt Deep Impact Socket
TCIM31022	22mm	3/4" Drive 6pt Deep Impact Socket
TCIM31023	23mm	3/4" Drive 6pt Deep Impact Socket
TCIM31024	24mm	3/4" Drive 6pt Deep Impact Socket
TCIM31025	25mm	3/4" Drive 6pt Deep Impact Socket
TCIM31026	26mm	3/4" Drive 6pt Deep Impact Socket
TCIM31027	27mm	3/4" Drive 6pt Deep Impact Socket
TCIM31028	28mm	3/4" Drive 6pt Deep Impact Socket
TCIM31029	29mm	3/4" Drive 6pt Deep Impact Socket
TCIM31030	30mm	3/4" Drive 6pt Deep Impact Socket
TCIM31031	31mm	3/4" Drive 6pt Deep Impact Socket
TCIM31032	32mm	3/4" Drive 6pt Deep Impact Socket
TCIM31033	33mm	3/4" Drive 6pt Deep Impact Socket
TCIM31034	34mm	3/4" Drive 6pt Deep Impact Socket
TCIM31035	35mm	3/4" Drive 6pt Deep Impact Socket

Part No.	Size	Description
TCIM31036	36mm	3/4" Drive 6pt Deep Impact Socket
TCIM31037	37mm	3/4" Drive 6pt Deep Impact Socket
TCIM31038	38mm	3/4" Drive 6pt Deep Impact Socket
TCIM31039	39mm	3/4" Drive 6pt Deep Impact Socket
TCIM31040	40mm	3/4" Drive 6pt Deep Impact Socket
TCIM31041	41mm	3/4" Drive 6pt Deep Impact Socket
TCIM31042	42mm	3/4" Drive 6pt Deep Impact Socket
TCIM31043	43mm	3/4" Drive 6pt Deep Impact Socket
TCIM31044	44mm	3/4" Drive 6pt Deep Impact Socket
TCIM31045	45mm	3/4" Drive 6pt Deep Impact Socket
TCIM31046	46mm	3/4" Drive 6pt Deep Impact Socket
TCIM31047	47mm	3/4" Drive 6pt Deep Impact Socket
TCIM31048	48mm	3/4" Drive 6pt Deep Impact Socket
TCIM31049	49mm	3/4" Drive 6pt Deep Impact Socket
TCIM31050	50mm	3/4" Drive 6pt Deep Impact Socket
TCIM31051	51mm	3/4" Drive 6pt Deep Impact Socket
TCIM31052	52mm	3/4" Drive 6pt Deep Impact Socket
TCIM31054	54mm	3/4" Drive 6pt Deep Impact Socket
TCIM31055	55mm	3/4" Drive 6pt Deep Impact Socket

Impact Sockets - 3/4" Drive Standard + Long Series

INDUSTRIAL

Part No. Size Description

Drive impact bit sockets 3/4"

TCIM32017	H17	3/4" Drive Impact Bit Socket (100mm)
TCIM32019	H19	3/4" Drive Impact Bit Socket (100mm)
TCIM32021	H21	3/4" Drive Impact Bit Socket (100mm)
TCIM32022	H22	3/4" Drive Impact Bit Socket (100mm)
TCIM32024	H24	3/4" Drive Impact Bit Socket (100mm)



TCIM32017-TCIM32024

3/4"

Part No. Size Description

Drive budd wheel impact socket 3/4"

TCIM34017	17mm	3/4" Drive 4pt Budd Wheel Impact Socket
TCIM34019	19mm	3/4" Drive 4pt Budd Wheel Impact Socket
TCIM34020	20mm	3/4" Drive 4pt Budd Wheel Impact Socket
TCIM34021	21mm	3/4" Drive 4pt Budd Wheel Impact Socket



TCIM34017-TCIM34021

Part No. Size Description

Drive budd wheel deep impact socket 3/4"

TCIM35017	17mm	3/4" Drive 4pt Budd Wheel Deep Impact Socket
TCIM35019	19mm	3/4" Drive 4pt Budd Wheel Deep Impact Socket
TCIM35020	20mm	3/4" Drive 4pt Budd Wheel Deep Impact Socket
TCIM35021	21mm	3/4" Drive 4pt Budd Wheel Deep Impact Socket



TCIM35017-TCIM35021

Impact Sockets - 1" Drive Standard + Long Series

1"



TCIM50019-TCIM50027



TCIM50030-TCIM50032



TCIM50035-TCIM50038



TCIM50040-TCIM50050



TCIM50052-TCIM50065



TCIM50070-TCIM50075

Part No. Size Description

Drive impact sockets 1"

TCIM50019	19mm	1" Drive 6pt Impact Socket
TCIM50020	20mm	1" Drive 6pt Impact Socket
TCIM50021	21mm	1" Drive 6pt Impact Socket
TCIM50022	22mm	1" Drive 6pt Impact Socket
TCIM50024	24mm	1" Drive 6pt Impact Socket
TCIM50027	27mm	1" Drive 6pt Impact Socket
TCIM50030	30mm	1" Drive 6pt Impact Socket
TCIM50032	32mm	1" Drive 6pt Impact Socket
TCIM50035	35mm	1" Drive 6pt Impact Socket
TCIM50036	36mm	1" Drive 6pt Impact Socket
TCIM50038	38mm	1" Drive 6pt Impact Socket
TCIM50040	40mm	1" Drive 6pt Impact Socket

Part No. Size Description

Drive impact sockets 1"

TCIM50042	42mm	1" Drive 6pt Impact Socket
TCIM50044	44mm	1" Drive 6pt Impact Socket
TCIM50045	45mm	1" Drive 6pt Impact Socket
TCIM50050	50mm	1" Drive 6pt Impact Socket
TCIM50052	52mm	1" Drive 6pt Impact Socket
TCIM50054	54mm	1" Drive 6pt Impact Socket
TCIM50055	55mm	1" Drive 6pt Impact Socket
TCIM50060	60mm	1" Drive 6pt Impact Socket
TCIM50065	65mm	1" Drive 6pt Impact Socket
TCIM50070	70mm	1" Drive 6pt Impact Socket
TCIM50075	75mm	1" Drive 6pt Impact Socket

Part No. Size Description

Drive deep impact sockets 1"

TCIM51030	30mm	1" Drive 6pt Deep Impact Socket
TCIM51032	32mm	1" Drive 6pt Deep Impact Socket
TCIM51033	33mm	1" Drive 6pt Deep Impact Socket
TCIM51034	34mm	1" Drive 6pt Deep Impact Socket



TCIM51030-TCIM51034

Impact Sockets - Adaptor + Extensions

INDUSTRIAL

Part No.	Size	Description
Ball impact adaptor		
TCIM90001	1/2" F X 3/8" M	Impact Adaptor
TCIM90002	1/2" F X 3/4" M	Impact Adaptor
TCIM90003	3/4" F X 1/2" M	Impact Adaptor
TCIM90004	1/2" F X 1" M	Impact Adaptor
TCIM90005	1" F X 3/4" M	Impact Adaptor
TCIM90006	1/2" F X 1/2" M	Impact Adaptor Uni. Swivel

Part No.	Size	Description
Drive impact extension bar		
TCIM91001	2" X 1/2"	Drive Impact
TCIM91002	3" X 1/2"	Drive Impact
TCIM91003	5" X 1/2"	Drive Impact
TCIM91004	6" X 1/2"	Drive Impact
TCIM91005	10" X 1/2"	Drive Impact

Part No.	Size	Description
Drive impact extension bar		
TCIM92001	4" X 3/4"	Drive Socket Impact
TCIM92002	6" X 3/4"	Drive Impact
TCIM92003	7" X 3/4"	Drive Impact
TCIM92004	8" X 3/4"	Drive Impact
TCIM92005	10" X 3/4"	Drive Impact
TCIM92006	12" X 3/4"	Drive Impact

Part No.	Size	Description
Drive impact extension bar		
TCIM93004	4" X 1"	Drive Impact
TCIM93006	6" X 1"	Drive Impact
TCIM93008	8" X 1"	Drive Impact



Industrial Socket Sets 3/4" & 1" Drive

Part No.	Size	Description
Socket Sets		
TCIMH006039	20 Pce 3/4"	6 PT Socket Set 19-50mm
TCIMH06042	14 Pce 3/4"	6 PT Socket Set 22-50mm
TCIMH08043	12 Pce 1"	6 PT Socket Set 46-80mm



3/4"

Contents & Sizes:
 Sockets - 19, 21, 22, 24, 27, 30, 32, 36, 38, 41, 46 & 50mm
 1 Pce 3/4" Drive Ratchet Handle, 24T
 1 Pce 3/4" Drive Universal Joint
 3 Pce 3/4" Drive Extension Bars, 4", 8" & 16"
 1 Pce 3/4" Drive Sliding T-Bar, 20"
 2 Pce Adaptors, 3/4" F x 1/2" M & 3/4" F x 1" M



TCIMH006042
 Contents & Sizes:
 Sockets - 22, 24, 27, 30, 32, 36, 38, 41, 46 & 50mm
 2 Pce 3/4" Drive Extension Bars, 8" & 16"
 1 Pce 3/4" Drive Sliding T-Bar, 20"
 1 Pce 3/4" Drive Ratchet Handle

3/4"



TCIMH08043
 Contents & Sizes:
 Sockets - 46, 50, 55, 60, 65, 70, 75, 80mm
 2 Pce 1" Drive Extension Bars, 8" & 16"
 1 Pce 1" Drive Sliding T-Bar, 20"
 1 Pce 1" Drive Ratchet Handle, 24T

1"



Lock Mortiser - EGI



Part No.	Description
EG1	Lock Mortising Attachment

Accessories:

EG2	17mm Cutter
EG3	19mm Cutter
EG4	22mm Cutter
EG9	25mm Cutter
EG6	Bearings & Bushes
EG16	Shaft with Mad Bit 17mm
EG2-2	TCT Cutter for EG1 17.15mm

INDUSTRIAL

The very rugged design and simple handling makes the "Lock Mortiser" an ideal machine for local conditions.

Time Saving:

Cuts your slot in less than 1 minute.

Saving on skilled labour:

Once the machine is set it can be handled by almost anybody.

No wrecked doors:

Accurate positioning of your door lock, handle and keyhole.

EG1 includes one 17mm (EG2) cutter

Call our office for spares



EG1

Lock Mortiser - Souber Tools

<https://www.youtube.com/watch?v=zRvNplgs-Og>



5 minute MORTICER

The choice of locksmiths

Part No. Description

ST JIG 1C	Lock Morticer w/18 & 22mm Cutters in plastic case
ST JIG LS	Long Shaft Screw Type
ST JIG SS	Standard Shaft Screw Type
ST DBB KIT	Upgrade Kit 19,22,25mm Cutters, Shaft, Spanners
ST CWB13	Carbide Tipped Cutter 13.2mm
ST CWB15	Carbide Tipped Cutter 14.6mm
ST CWB16	16.2mm Carbide Tipped Cutter for Wood
ST CWB18	17.5mm Carbide Tipped Cutter for Wood
ST CWB19	19mm Carbide Tipped Cutter for Wood
ST CWB20	20mm Carbide Tipped Cutter for Wood
ST CWB22	22mm Carbide Tipped Cutter for Wood
ST CWB23	23mm Carbide Tipped Cutter for Wood
ST CWB25	25mm Carbide Tipped Cutter for Wood
ST10950	Long Wood Drill 10 x 950mm
ST101250	Long Wood Drill 10 x 1250mm

INDUSTRIAL



Part No. Description

ST AB16	16.2mm Cutter for Aluminium
ST AB19	19mm Cutter for Aluminium
ST AB25	25.4mm Cutter for Aluminium
ST AB32	31.8mm Cutter for Aluminium
ST NAB16	16.2mm Cutter for Aluminium
ST NAB19	19mm Cutter for Aluminium
ST NAB25	25mm Cutter for Aluminium
ST PD18	17.6mm Plunging Cutter for Tubular Latches
ST PD23	23mm Plunging Cutter for Tubular Latches
ST PD25	25mm Plunging Cutter for Tubular Latches
ST DBB-GS	Grub screws for Lock Morticer
ST DBB-HK	Housing Kit Doors up to 55mm
ST DBB-HK-O	Offset Housing Kit
ST DBB-HK-S	Housing Kit Doors over 55mm
ST DBB-LD-A	Long Drill Housing Adaptor
ST DBB-LS	Long Shaft
ST DBB-OB	Standard Bushes - Pair
ST DBB-SB-HK	Small Bore System Housing Kit
ST DBB-SBS	Small Bore System Shaft & Stop
ST DBB-SRK	Slider Repair Kit
ST DBB-SS	Standard Shaft
ST DBB-DS	Depth Stop
ST DBB-SP	Spanner for Mortice Jig

INDUSTRIAL

Hollow Square Mortice Chisels

Standard	Industrial	INDUSTRIAL	Description
MC01	MC01-1		Mortice Chisel 1/4"
MC02	MC02-1		Mortice Chisel 5/16"
MC03	MC03-1		Mortice Chisel 3/8"
MC04	MC04-1		Mortice Chisel 1/2"
MC05	MC05-1		Mortice Chisel 5/8"



MCA66-62-58

Mortice Chisel Attachment 66/62/58 w/out chisels
For use in a drill press with the mortise chisel attachment. Cuts square holes.

Wood Turning Chisels

Part No.	Description
CH10002	6 Pce HSS Wood Turning Chisel Set in Aluminium Case
CH10003	8 Pce HSS Wood Turning Chisel Set in Aluminium Case
CH10004	8 Pce Wood Turning Chisel Set in Cardboard box
CH10005	5 Pce HSS Wood Turning Chisel Set in Wooden Case
CH10006	5 Pce 27mm HSS Wood Turning Chisel Set in Wood Case
CH20003	6 Pce Wood Carving Chisel Set in Wooden box
CH30001	3 Pce Wood Chisel Set PLUS Wooden Mallet
CH30002	4 Pce Wood Chisel Set
CH30003	12 Pce Wood Carving Chisel Set in Leather Pouch
CH30004	3 Pce Wood Chisel Set 140mm Blade 6, 12, 19 & 25mmw/PVC Handle
CH30005	2 Pce Wood Chisel Set 100mm Blade 12 & 19mmw/PVC Handle
TCWM001	Wooden Mallet 250 x 85mm, 195 - 205gram Beech Wood
TCWM002	Wooden Mallet 300 x 110mm, 290 - 300gram English Beech Wood
W0601	5 Pce Set in Wooden box - Overall length 255mm



CH10005



CH10002



CH30003



CH10003



CH20003



CH30001



CH30004



CH30005



TCWM001



TCWM002

Wood Chisels

Part No.	Size / Description
CH40006	6mm Wood Chisel
CH40008	8mm Wood Chisel
CH40010	10mm Wood Chisel
CH40012	12mm Wood Chisel
CH40014	14mm Wood Chisel
CH40016	16mm Wood Chisel
CH40019	19mm Wood Chisel
CH40022	22mm Wood Chisel
CH40025	25mm Wood Chisel
CH40028	28mm Wood Chisel
CH40030	30mm Wood Chisel
CH40032	32mm Wood Chisel
CH40038	38mm Wood Chisel



Hollow Punches

**NEW
PRODUCT**

TCHP009
9Pce Hollow Punch Set
Carbon Steel
Sizes : 2.5 - 10mm



Chisel Sets

Part No.	Size / Description
TCPU20207	3 Pce Cold Chisel Set - 16x12x165mm, 12.7x11x150mm, 9.5x8x138mm
TCPU20209	3 Pce Center Punch Set - 6.3x9.5x100mm, 5.4x11x128mm, 8x11x116mm
TCPU20210	3 Pce Long Pin Punch Set - 1.6x6.3x114mm, 2.4x8x140mm, 3.2x8x140mm
TCPU20302	6 Pce Chisel & Punch Set
TCPU20303	6 Pce Pin Punch Set - 10x2.5x150mm, 10x3.5x150mm, 10x4.5x150mm, 10x6x150mm, 12x8x150mm, 12x10x150mm
TCPU20309	3 Pce Cold Chisel Set - 10x8x142mm, 13x10x152mm, 16x13x172mm
TCPU20310	6 Pce Pin Punch set - 1.5, 3, 4, 5, 6, 8mm
TCPU20311	12 Pce Chisel & Punch Set - Cold; 12x15x150mm, 10x11x130mm, Centre Punch; 10x3x120mm, Pin Punch; 10x3x150mm, 10x4x150mm, 10x6x150mm

INDUSTRIAL



TCPU20207



TCPU20209



TCPU20210



TCPU20309



TCPU20311

Centre Punches

Part No.	Size / Description
TCPU03100	3 x 10 x 100mm Black Finish
TCPU04100	4 x 10 x 100mm Black Finish
TCPU05100	5 x 10 x 100mm Black Finish
TCPU10003	3 Pce Set 3/4/5 x 10 x 100mm

INDUSTRIAL

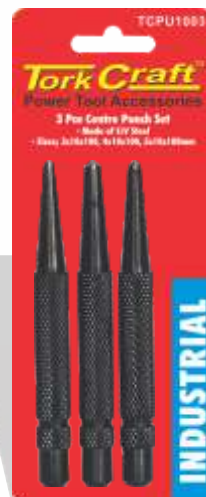

TCPU10003



TCPU20310



TCPU20302

Biscuit Jointing

Part No. BJ02 - Biscuit Joiner

- » 900W / 11000 RPM
- » Cuts slots for #0, #10 & #20 biscuits
- » Tungsten tipped blade

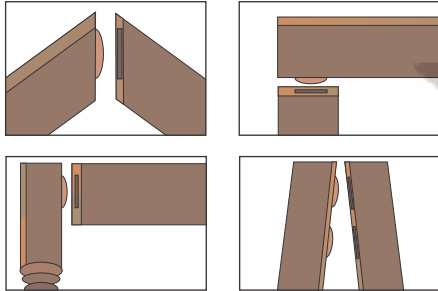

See website for spares
www.torkcraft.com

Biscuit jointing is stronger and can replace many conventional joining methods

Part No. Description

PC5551	Biscuits # 0 - 42 x 15 x 4mm (Box of 1000)
PC5551-50	Biscuits # 0 - 42 x 15 x 4mm (x 50)
PC5552	Biscuits # 10 - 53 x 20 x 4mm (Box of 1000)
PC5553	Biscuits # 20 - 58 x 23 x 4mm (Box of 1000)
PC5553-50	Biscuits # 20 - 58 x 23 x 4mm (x 50)
BIS020	Biscuits # 20 - 56 x 23 x 4mm (Box of 1000) Beech Wood



- Rounded smooth edges
- » for easy handling & inserting
- Recessed & embossed glue surface
- » Accurate glue distribution
- » Easy insertion into groove
- Diagonal fibre orientation
- » Excellent breaking strength

Fluted Wooden Dowels and Dowel Rods

Part No. Description

DOW0630-2	6 x 30mm (2 Kg bag)
DOW0840-2	8 x 40mm (2 Kg bag)
DOW1260-2	12 x 60mm (2 Kg bag)
DOW06030-50	6 x 30mm (50/Bag)
DOW08040-40	8 x 40mm (40/Bag)
DOW10040-30	10 x 40mm (30/Bag)
TCDW001	5 Pce Dowelling Kit Jig for 6, 8 & 10mm dowels

For glueing and jointing



TCDW001

Part No. Description

DOW20043	43 Pce Dowel Kit - 6, 8, 10mm
DOW20634	34 Pce Dowel Kit - 6mm
DOW20827	27 Pce Dowel Kit - 8mm
DOW21022	22 Pce Dowel Kit - 10mm



DOW20043



DOW20634



DOW20827



DOW21022

Clamps

Part No.	Description	Size
GERMAN F-TYPE CLAMP		
CL FCG50-150	German F-Type Clamp	50 x 150mm
CL FCG50-200	German F-Type Clamp	50 x 200mm
CL FCG50-250	German F-Type Clamp	50 x 250mm
CL FCG50-300	German F-Type Clamp	50 x 300mm
CL FCG120-300	German F-Type Clamp	120 x 300mm
CL FCG120-400	German F-Type Clamp	120 x 400mm
CL FCG120-500	German F-Type Clamp	120 x 500mm
CL FCG120-600	German F-Type Clamp	120 x 600mm
CL FCG120-800	German F-Type Clamp	120 x 800mm
CL FCG120-1000	German F-Type Clamp	120 x 1000mm
CL FCG120-1200	German F-Type Clamp	120 x 1200mm
CL FCG120-1500	German F-Type Clamp	120 x 1500mm
CL FCG120-2000	German F-Type Clamp	120 x 2000mm

SASH CLAMP HEAVY DUTY		
CL GC600	Sash Clamp Heavy Duty	600mm
CL GC900	Sash Clamp Heavy Duty	900mm
CL GC1000	Sash Clamp Heavy Duty	1000mm
CL GC1250	Sash Clamp Heavy Duty	1250mm
CL GC1500	Sash Clamp Heavy Duty	1500mm
CL GC2000	Sash Clamp Heavy Duty	2000mm

SASH CLAMP STANDARD		
TCC10600	Sash Clamp Standard	600mm
TCC10900	Sash Clamp Standard	900mm
TCC11200	Sash Clamp Standard	1200mm
TCC11500	Sash Clamp Standard	1500mm
TCC11800	Sash Clamp Standard	1800mm
TCC00001	Spare Jaw Set for standard sash clamps	

G CLAMP HEAVY DUTY		
CL HDCC1	G Clamp Heavy Duty	1"/25mm
CL HDCC2	G Clamp Heavy Duty	2"/50mm
CL HDCC3	G Clamp Heavy Duty	3"/75mm
CL HDCC3-2	Twin Pack	3"/75mm
CL HDCC4	G Clamp Heavy Duty	4"/100mm
CL HDCC4-2	Twin Pack	4"/100mm
CL HDCC5	G Clamp Heavy Duty	5"/125mm
CL HDCC6	G Clamp Heavy Duty	6"/150mm
CL HDCC6-2	Twin Pack	6"/150mm
CL HDCC8	G Clamp Heavy Duty	8"/200mm
CL HDCC10	G Clamp Heavy Duty	10"/250mm
CL HDCC12	G Clamp Heavy Duty	12"/300mm

QUICK CLAMP		
CL NCHB4	Quick Clamp	4"/100mm
CL NCHB6	Quick Clamp	6"/150mm
CL NCHB12	Quick Clamp	12"/300mm
CL NCHB18	Quick Clamp	18"/450mm
CL NCHB24	Quick Clamp	24"/600mm
CL NCHB36	Quick Clamp	36"/900mm



Features/Benefits

- Pre-tensioned main bar
- Non-marking pressure pads
- All steel construction
- Wooden handles



Features/Benefits

- Primarily designed for clamping large work pieces during fabrication and glueing in joinery, carpentry and boat building.
- With cast iron heads.



Features/Benefits

- » For use in wood, metal working and other trades



Bar Clamps

Part No.	Description
TCC00600	600mm Bar Clamp - Aluminium
TCC00900	900mm Bar Clamp - Aluminium
TCC01200	1200mm Bar Clamp - Aluminium
TCC01500	1500mm Bar Clamp - Aluminium
TCC01800	1800mm Bar Clamp - Aluminium

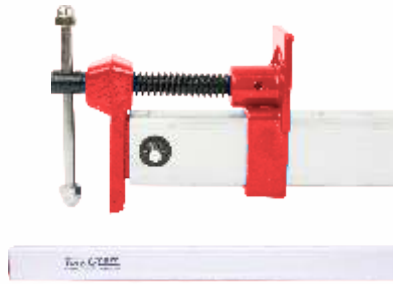

Features/Benefits

- Rigid aluminium construction
- Spring loaded latch locks jaws in position
- Suitable for light clamping jobs
- Light and easy to handle

Clamps

Part No.	Description	Size
QUICK ADJUST G-CLAMP		
CL AJCC23	G Clamp Quick Adjust	50 - 75mm
CL AJCC47	G Clamp Quick Adjust	100 - 175mm



Part No.	Description	Size
QUICK ADJUST C-CLAMP		
CL AJCC36	C Clamp Quick Adjust	75 - 150mm



Part No.	Description	Size
C-CLAMP - SETS		
CL CICC3A	C Clamp 3pc Set	1, 2 & 3"
CL CICC3B	C Clamp 3 pc Set	2, 3 & 4"
CL CICC4B	CI Type C Clamp Set 4pc	2, & 4"



CL CICC3A

CL CICC3B

8
pce

Part No.	Description	Size
SPRING CLAMPS - NYLON		
CL NSCHB3	Nylon Spring Clamp	3"/75mm
CL NSCHB4	Nylon Spring Clamp	4"/100mm
CL NSCHB6	Nylon Spring Clamp	6"/150mm
CL NSCHB9	Nylon Spring Clamp	9"/230mm
CL NSCHB06	6pce Set Nylon Spring Clamp	75/100/150mm
CL NSCHB1-01	8pce Set Nylon Spring Clamp	25mm
CL NSCHB1-02	20pce Set Nylon Spring Clamp	25mm
CL NSCHB1-03	15pce Nylon Spring Clamp	25mm
	- Plastic Jar Various colours	



CL NSCHB06

CL NSCHB1-01

20
pce



CL NSCHB1-02



15
pce

CL NSCHB1-03

Part No.	Description	Size
SPRING CLAMPS - STEEL		
CL SPC1	Spring Clamp	1"/25mm
CL SPC2	Spring Clamp	2"/50mm
CL SPC3	Spring Clamp	3"/75mm

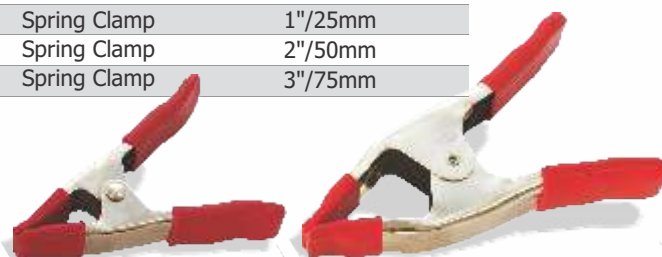

Pipe Clamps

- Part No. CL PCB34**
 » Pipe clamp for 19mm pipe
 » Use on standard galvanised 3/4" plumbing pipe



Clamps



Part No. TCV07565
Quick Release Corner Clamp
75 x 65mm



Part No. TCV08075
Corner Clamp
80 x 75mm



Part No. TCV09568
Corner Clamp 90 Degree
95 x 68mm
- Swivelling head applies even force
- Two fixed clamping faces



Suitable for framing and light weight joinery



Vices



Part No. TCV01810
Vice & Drill Clamp Set
78 x 50mm



Part No. TCV08065
Table Vice
80 x 65mm



Part No. TCV06040
Mini Table Vice
60 x 40mm



Part No. TCV04043
Drill Stand
Multi-Angle
43mm Collar
For portable drills



Drill Stands / Angle Grinder Stand



Part No. TC04700
Drill Stand for Portable Drills
Spares:
TC04700B
Main Body for Drill Press TC04700
TC04700P
Press Handle Attachment for TC04700



Part No. TC04300
115mm Angle Grinder Stand



Picture Framing Clamps



Part No. TC01590
Band Clamp - 4m web plus corners

Magnetic Inspection Tools



TCMG7030
3 Pce MAGNETIC
Inspection Tool Set

- Contents;
- » 1 x Telescopic Magnet 1.5kg pick-up
 - » 1 x Round Inspection Mirror Ø30
 - » 1 x Elliptoid Inspection Mirror 25 x 50mm



Magnetic Welding Holder

- » Strong powerful magnets
- » Multiple angles to hold piece at the correct angle
- » Used in welding, soldering, assembly, marking-off, pipe installation, demagnetising

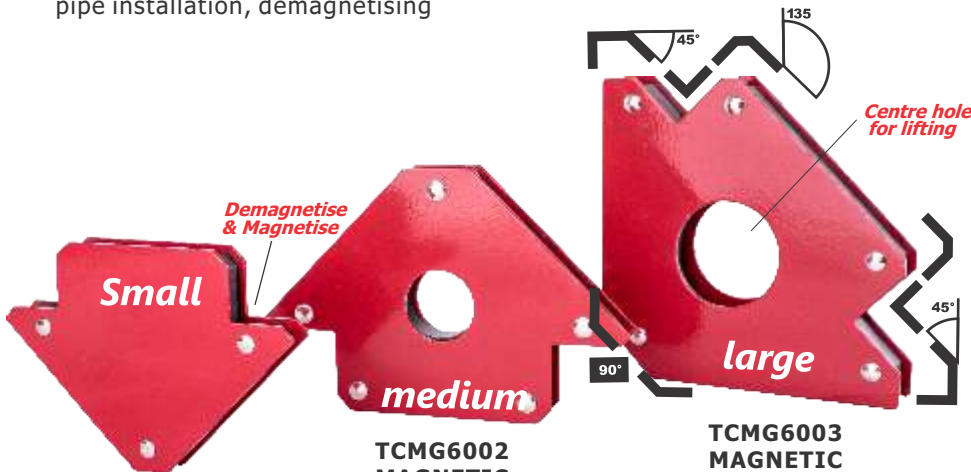

TCMG6001
MAGNETIC
Welding Holder
11.4kg Pull Force
45, 90 & 135°
Multi Angle

TCMG6002
MAGNETIC
Welding Holder
22.7kg Pull Force
45, 90 & 135°
Multi Angle

TCMG6003
MAGNETIC
Welding Holder
34kg Pull Force
45, 90 & 135°
Multi Angle



TCMG6004
MAGNETIC
Welding Holder
9kg Pull Force
15, 60, 90 & 120°
Multi Angle



TCMG6005
MAGNETIC
Welding Holder
9kg Pull Force
45, 67, 90, 112 & 135°
Multi Angle

Magnetic Tool Organiser

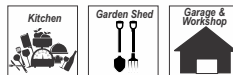

TCMG7018
3 Pce Magnetic Tool Organiser & Holder
200, 305 & 460mm Bar Length



KEEP TOOLS ORGANISED

- » Keeps tools neatly organised in the kitchen, garden shed, garage or workshop
- » A great addition for any toolshop or storage area
- » Powerful magnets can hold random metal tools in place
- » Comes with installation screws

TORK CRAFT 4 in 1 Work Station

Part No. TCWS002 4 in 1 Work Station

Features:

1. Work Bench

- » Work surface with ruler and compass
- » Drill holes and saw slot
- » Stainless steel plate for cutting and hammering

2. Hand Trolley

- » 113 x 47cm Loading Surface
- » Two fixed wheels and two with brakes
- » Inside handles allow access through smaller areas

3. Floor Trolley

- » Ideal for working under vehicles
- » Two fixed wheels and two with brakes
- » New crosspieces help spread the load better

4. Scaffold

- » Anti-slip step board
- » Two height levels (56 & 80cm)
- » Max. load capacity when legs are at 80cm height is 150kg
- » Max. load capacity when legs are at 56cm height is 300kg
- » Aluminium legs

» Work Bench » Scaffold
» Hand Trolley » Floor Trolley



1. Work Bench



2. Hand Trolley



3. Floor Trolley



4. Scaffold

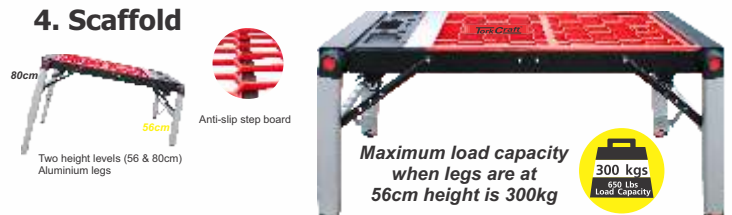

TRANSPORT

Standing Desks



TCWS003
Standing Desk Desktop Size
» Size 810mm x 520mm
» Height 150 - 450mm



TCWS004
Standing Desk Desktop Size
» Size 900mm x 580mm
» Height 150 - 510mm



TCWS005
Standing Desk Desktop Size
» Size 1067mm x 580mm
» Height 150 - 510mm

ADJUSTABLE STAND DESK

TURN ANY STATIONARY DESKTOP INTO A STANDING DESK



Cordless Power Tools

Tork Craft **Atomic Platform** is indicated by the Atom symbol on the label. Any tool where this symbol is present is compatible with the **Atomic** battery platform

Atomic

Power Platform



NEW PRODUCT

STANDARD

TC20001 Drill Driver DD10

Voltage : 20V Lithium-Ion
Speed Settings : 2
Setting 1 : 0 - 400rpm
Setting 2 : 0 - 1100rpm
Maximum Torque : 35N.m
Chuck Capacity : 10mm

Accessories:

2Ah Battery (TC20 BAT20) & Charger (TC20VABC-01)
Wood Drill bits: Size 2, 3, 4, 5, 6 & 8mm / Steel Drill Bits: Size 2, 3, 4, 5, 6mm
Insert Bit set: 32 Pcs 25mm Bits
1 x Magnetic Bit Holder
Blow Moulded storage and carry case



NEW PRODUCT

STANDARD

TC20002 Drill & Impact Driver Twin Pack with Charger & 2 x 2AH Batteries

Voltage : 20V Lithium-Ion
No Load Speed
Settings : 2x
Setting 1 : 0 - 400rpm
Setting 2 : 0 - 1100rpm
Maximum Torque : 35N.m
Chuck Capacity : 10mm
Colour box with carry bag



NEW PRODUCT

CONTRACTOR

TC20030 Impact Drill Driver ID13

Voltage : 20V Lithium-Ion
No Load Speed
Settings : 2x
Setting 1 : 0 - 500rpm / Setting 2 : 0 - 1800rpm
Maximum Torque : 50N.m
Chuck Capacity : 13mm
Impact Rate: (IPM = Impacts Per/Min)
Speed Setting 1 : 0 - 9000ipm / Speed Setting 2 : 0 - 32400ipm
Drill Capacity : Wood : 32mm / Steel : 13mm

Tool Features:

LED Light / Metal Belt Hook / Impact Function / 19x Torque/Clutch Settings / Drill and Impact Drill Settings

Accessories:

2 x 2Ah Batteries (TC20 BAT20)
Charger (TC20VABC-01)
Masonry Drill bits: Size 4, 6, 8, 10mm / Steel Drill Bits: Size 2, 3, 4, 5, 6, 8, 10mm (Fully Ground Steel)
Insert Bit set: 32x pcs 25mm Bits (S2 Metal) & 1x Magnetic Bit Holder
Blow Moulded storage and carry case



NEW PRODUCT

INDUSTRIAL

TC20060 Impact Drill Brushless ID13B

Voltage : 20V Lithium-Ion
Motor : Brushless 20v
No Load Speed Settings : 2x
Setting 1 : 0 - 500rpm / Setting 2 : 0 - 1800rpm
Maximum Torque : 50N.m
Chuck Capacity : 13mm
Impact Rate : (IPM = Impacts Per/Min)
Speed Setting 1 : 0 - 9000ipm / Speed Setting 2 : 0 - 32400ipm
Drill Capacity : Wood : 32mm / Steel 13mm

Tool Features: LED Light / Metal Belt Hook / Impact Function / 19x Torque/Clutch Settings / Drill and Impact Drill Settings / Full metal, single sleeve, keyless chuck with auto-lock

Accessories:

2 x 2Ah Batteries (TC20 BAT20)
1 x Fast Charger (TC20VABC-01)
Masonry Drill bits: Size 4, 6, 8, 10mm / Steel Drill Bits: Size 2, 3, 4, 5, 6, 8, 10mm
Insert Bit set: 32x pcs 25mm Bits & 1x Magnetic Bit Holder
Blow Moulded storage and carry case

Cordless Power Tools

Tork Craft **Atomic Platform** is indicated by the Atom symbol on the label. Any tool where this symbol is present is compatible with the **Atomic** battery platform

Atomic Power Platform



**NEW
PRODUCT**

TC20110 Angle Grinder Brushless AG115B

NB: Recommended to be used with 4Ah battery for longer runtime

Voltage : 20V Lithium-Ion
Motor : Brushless 20v
No Load Speed Settings : 1x
Setting 1 : 7000rpm
Capacity : 115mm discs, pads & blades
M14 Threaded Shaft

Tool Features :

Ergonomic side handle with TPR grip and built-in arbor nut Spanner
3x threaded holes for various handle positions
Heavy duty brushless motor and gearbox.

Accessories:

Blow Moulded storage and carry case with slots for 2x 4Ah Batteries and Charger
Batteries not included

INDUSTRIAL

TC20190 Rotary Hammer RH500

NB: Recommended to be used with 4Ah or larger battery for longer runtime

Voltage : 20V Lithium-Ion
No Load Speed Settings : 1x
Setting 1 : 0 - 1500rpm
Maximum Torque : 50N.m
Chuck Capacity : SDS+
Impact Rate : (IPM 0 - 5500ipm)
Drill Capacity : Wood: 26mm / Steel: 13mm / Concrete: 20mm

Tool Features:

LED Light / 4 Functions / Chisel / Drill / Impact & Drill / Free rotation chisel / SDS+ chuck

Accessories:

Ergonomic side handle with TPR grip and with easy rotate & release mounting system
Quick release & adjust depth stop
Blow Moulded storage and carry case with slots for 2x 4Ah
Batteries not included

INDUSTRIAL



**NEW
PRODUCT**



TC20 BAT20 - BATTERY 20V 2.0AH LI-ION

Voltage : 20V Lithium-Ion
Capacity : 2000mah (2Ah)

TC20 BAT40 - BATTERY 20V 4.0AH LI-ION

Voltage : 20V Lithium-Ion
Capacity : 4000mah (4Ah)

Tool Features :

LED capacity indicator Lights
Vents for cooling function with
Smart airflow Charger TC20VABC-02

**NEW
PRODUCT**



TC20VABC-01

Battery Charger Smart 2.3A - 5A
2.0AH Li-ion Battery A-Series

Tool Features :

LED charge status indicator
Voltage : 220V
Plug : 2 pin standard



TC20VABC-02

Battery Charger Smart 2.3A - 5A
4.0AH Li-ion Battery A-Series

Tool Features :

- » Smart Charger functionality
- » LED light indicators showing charge status and operation mode
- » Cooling function to cool batteries prior to and during charging after undergoing heavy use
- » Battery balance and repair function to maintain battery health and longevity
 - » Voltage : 220V
 - » Plug : 2 pin standard



Paint Mixers



- » Designed to mix all viscous fluids quickly and effectively.
- » Use to mix paints, coatings, wall textures and adhesives.
- » Fits on power drills

Part No.	Description	
PM507	Mixer Paint/Liquids 80 x 400mm	Galvanized
PM508	Mixer Paint/Liquids 100 x 500mm	Galvanized
PM509	Mixer Paint/Liquids 120 x 500mm	Galvanized
PM510	Mixer Paint/Liquids 60 x 350mm	Red Painted
PM511	Mixer Paint/Liquids 60 x 400mm	Red Painted
PM512	Mixer Paint/Liquids 80 x 400mm	Red Painted
PM513	Mixer Paint/Liquids 100 x 600mm	Red Painted
PM514	Mixer Paint/Liquids 120 x 600mm	Red Painted



Staple Gun

Part No.	Description
TCSG0210	Staple Gun Heavy Duty c/w 1 Box 200 Pce 1.2mm x 8mm Staples
TCSG0500	Staple Gun Light Duty c/w 2 Boxes 400 Pce 0.7mm x 8mm Staples
TCSG02108	1250pce Staples - T50 x 8mm Heavy Duty
TCSG02110	1250pce Staples - T50 x 10mm Heavy Duty
TCSG02112	1250pce Staples - T50 x 12mm Heavy Duty
TCSG05006	1000pce Staples - JT21 x 6mm Light Duty
TCSG05008	1000pce Staples - JT21 x 8mm Light Duty



TCSG0210

- » Suitable for insulation, house wraps, roofing, wiring, carpeting & upholstery
- » All steel construction for long life
- » Compact design for easy portability & operation

TCSG0500

- » Suitable for insulation, house wraps, roofing, wiring, carpeting & upholstery
- » All steel magazine construction provides smooth, durable sliding surface for staples
- » Ergonomic steel handle for greater comfort and grip
- » Convenient bottom loading allows for quick and easy reloading
- » Chrome plating surface for anti-rust and corrosion resistant



Palm Wrench



TCPALM01 - Sold as 12 Units per Display Box
TCPALM-01 - 1 Pce - 8, 10, 11, 13, 14, 16 & 17mm
FEATURES

- » 7 Universal Spline Socket in 1
- » Finally a tool designed specifically for flexible connectors
- » Handy palm size, allows easy use in the most confined spaces
- » Metric Sizes : 8, 10, 11, 13, 14, 16 & 17mm
- » Depth of sockets = 11mm
- » Go-through design allows easy access
- » Cr-Mo steel for strength and durability
- » Taper fits all brands of connector
- » No more adjusting of wrenches
- » Bit holder design



Leather Hole Punch

Part No.	Description
TC4300	Leather Hole Punch & Grommet Setting Tool Kit c/w 100 Eyelets
TC4301	Spare Eyelets x 400pc for TC4300
TC4302	Grommet Setting Tool Kit c/w 10 Eyelets 7mm
TC4302-1	Spare Eyelets x 12pc 7mm for TC4302
TC4303	Grommet Setting Tool Kit c/w 10 Eyelets 8mm
TC4303-1	Spare Eyelets x 12pc 8mm for TC4303
TC4304	Grommet Setting Tool Kit c/w 10 Eyelets 12mm
TC4304-1	Spare Eyelets x 12pc 12mm for TC4304
TC4302-500	Spare Eyelets 7mm Bulk Bag
TC4303-500	Spare Eyelets 8mm Bulk Bag
TC4304-500	Spare Eyelets 12mm Bulk Bag



» Hole Sizes;
 2.5, 3, 3.5, 4, 4.5 & 5mm

Grease Guns

- » Use these grease guns to apply lubricant
- » Positive grip plunger rod handle
- » Non slip grip



INDUSTRIAL **TCGG01001**
Lever Type Grease Gun
 » 53mm Plunger
 » 400gms Cartridge Fill Type
 » Produce Pressure: 10,000PSI / 690 Bar
 » Aluminium die cast head with filler nipple
 c/w 150mm cranked tube & 4 jaw coupler



INDUSTRIAL **TCGG01002**
Lever Type Grease Gun
 » 55mm Plunger
 » Bulk fill type 500gms
 » Produce Pressure: 10,000PSI/690 Bar
 » Aluminium die cast head with filler nipple
 c/w 150mm cranked tube & 4 jaw coupler



STANDARD **TCGG01004**
Lever Type Grease Gun
 » Cartridge fill type
 » 53mm Plunger
 » 400gms Cartridge fill type
 » Produce press 6000PSI / 413 Bar
 c/w 150mm cranked tube & 4 jaw coupler head made from sheet metal



INDUSTRIAL **TCGG01005**
Pistol Grip Grease Gun
 » Cartridge fill type
 » 53mm Plunger
 » 400gms Cartridge
 » Produce press 6000PSI / 413 Bar
 » Aluminium die cast head with filler nipple
 c/w 150mm cranked tube & 300mm flex nylon hose with 4 jaw coupler



STANDARD **TCGG01006**
Pistol Grip Grease Gun
 » Cartridge fill type
 » 53mm Plunger
 » 400gms Cartridge
 » Aluminium die cast head with filler nipple
 » Produce press 4000PSI / 275 Bar
 c/w 150mm cranked tube & 300mm flex nylon hose with 4 jaw coupler



TCGG02000
Oil can
 » 500ml
 » 175mm spout
 » Powder coated finish
 » Steel pump mechanism



TCGG04001
 Hydraulic 3 Jaw Coupler 1/8" Blister
TCGG04002
 Hydraulic 3 Jaw Coupler 1/8" Bulk
TCGG04003
 Hydraulic 4 Jaw Coupler 1/8" Blister
TCGG04004
 Hydraulic 4 Jaw Coupler 1/8" Bulk



Grease Gun Hose
 300mm
 (400 Bar/5800 Psi
 (id4.1 Od10.8mm)
TCGG03001
 Blister
TCGG03003
 Bulk



Grease Gun Hose
 450mm
 (400 Bar/5800 Psi
 (id4.1 Od10.8mm)
TCGG03002
 Blister
TCGG03004
 Bulk

Mortar & Grout Gun

- TCMG1570
Mortar & Grout Gun**
- » 1000ml
 - » 310mm 2000N
 - » C/w 2 x Nozzles & Mixer



Polyurethane Foam Guns

Recommended Foam Gun Cleaner
Use RAWLPLUG RAW R-RPC-0500

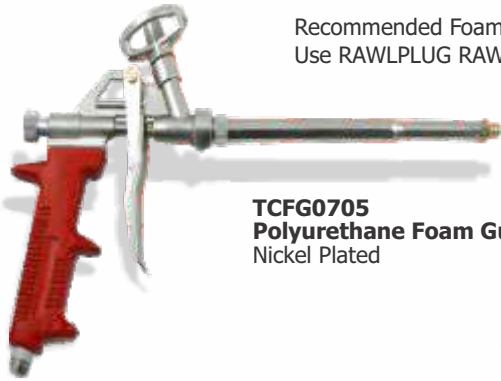

- TCFG0705
Polyurethane Foam Gun**
Nickel Plated



- TCFG1425
Polyurethane Foam Gun**
Teflon Coated Non Stick

Caulking Guns



- TCCG1331
Silicone Caulk Gun**
- » Aluminium handle and trigger
 - » Max. pushing power; 4500N
 - » Capacity; 310ml Single cartridge



- TCCG1360
Chemical Anchor Caulk Gun**
- » Aluminium handle and trigger
 - » Max. pushing power; 4000N
 - » Capacity; 380ml coaxial two component cartridge



- TCCG1363
Chemical Anchor Caulk Gun**
- » Aluminium handle and trigger
 - » Max. pushing power; 4000N
 - » Capacity; 200ml two component cartridge



- TCCG0928
Non-Drip Silicone Caulk Gun**
- » Heavy duty plastic
 - » Max. pushing power 1300N
 - » Capacity; 310ml single cartridge
 - » Nozzle cutter / Non-drip function



- TCCG0931
One-hand Silicone Caulk Gun**
- » Heavy duty plastic
 - » Max. pushing power 1300N
 - » Capacity; 310ml single cartridge
 - » Single hand operation design

Caulking Tool Set

PART NO. TCCK0100 4 Pce Caulking Tool Set

8 CORNERS

- » Standard
- » 5/8" Round
- » 5/8"
- » 25/64"
- » 5/16"
- » 13/64"
- » 90°
- » Grout

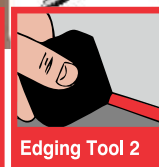
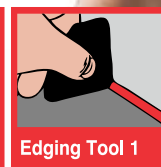
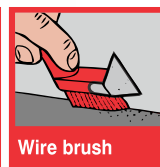
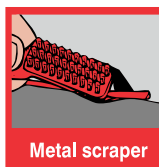

Deep Offset Combination Spanners

Part No.	Size
TC51006	6mm
TC51007	7mm
TC51008	8mm
TC51009	9mm
TC51010	10mm
TC51011	11mm
TC51012	12mm
TC51013	13mm
TC51014	14mm
TC51015	15mm
TC51016	16mm
TC51017	17mm
TC51018	18mm
TC51019	19mm
TC51020	20mm
TC51021	21mm
TC51022	22mm
TC51023	23mm
TC51024	24mm
TC51025	25mm
TC51026	26mm
TC51027	27mm
TC51028	28mm
TC51030	30mm
TC51032	32mm



Combination Spanners

Part No.	Size
TC50006	6mm
TC50007	7mm
TC50008	8mm
TC50009	9mm
TC50010	10mm
TC50011	11mm
TC50012	12mm
TC50013	13mm
TC50014	14mm
TC50015	15mm
TC50016	16mm
TC50017	17mm
TC50018	18mm
TC50019	19mm
TC50020	20mm
TC50021	21mm
TC50022	22mm
TC50023	23mm
TC50024	24mm
TC50025	25mm
TC50026	26mm
TC50027	27mm
TC50028	28mm
TC50030	30mm
TC50032	32mm

Deep Offset Combination Spanner Sets

Part No.	Size
TC51106	6 Pce Set : 8, 10, 12, 13, 14 & 17mm
TC51108	8 Pce Set : 8, 9, 10, 11, 13, 14, 17 & 19mm
TC51112	12 Pce Set : 6 - 22mm
TC51114	14 Pce Set : 8 - 24mm
TC51126	26 Pce Set : 6 - 32mm

Combination Spanner Sets

Part No.	Size
TC50106	6 Pce Set : 8, 10, 12, 13, 14 & 17mm
TC50108	8 Pce Set : 8, 9, 10, 11, 13, 14, 17 & 19mm
TC50112	12 Pce Set : 6 - 22mm
TC50114	14 Pce Set : 8 - 24mm
TC50126	26 Pce Set : 6 - 32mm
TC50226	26 Pce Set : 6 - 32mm Deep Offset



TC51126

TC50226

Shifting Spanners

Part No.	Size
TC52004	4" / 100mm 0 - 12.8mm
TC52006	6" / 150mm 0 - 19.2mm
TC52008	8" / 200mm 0 - 24mm
TC52010	10" / 250mm 0 - 28.8mm
TC52012	12" / 300mm 0 - 33.5mm
TC52015	15" / 375mm 0 - 43.1mm
TC52018	18" / 450mm 0 - 52mm



Forged Special CrV Steel



- » Full body hardened for improved performance
- » Extra wide design for comfortable grip
- » Hardened screw and jaw



Combination Pliers

Part No.	Size
TC530160	60 CRV 160mm
TC530180	60 CRV 180mm
TC530200	60 CRV 200mm

High Leverage C60 Steel



- » Hardened cutting edges
- » Improved cutting & holding force



Side/Diagonal Cutter

Part No.	Size
TC531160	60 CRV 160mm
TC531190	60 CRV 180mm
TC532160	60 CRV 200mm

Combination Pliers

Part No.	Size
TC533160	160mm
TC533180	170mm
TC533200	200mm

Contractor C55 Steel



- » Hardened cutting edges



Side/Diagonal Cutter

Part No.	Size
TC534160	160mm
TC534190	190mm



Long Nose Pliers

Part No.	Size
TC535160	160mm
TC535200	200mm
TC537160	Wire Stripper 160mm



Contractor C55 Steel

» Hardened cutting edges



TC603003 : 3 Pc Plier Set

- » 200mm Combination Plier
- » 150mm Side cutter
- » 150mm Long Nose Plier

Bent Nose Pliers

Part No.	Size
TC536160	160mm
TC536200	200mm



Pliers

Part No.	Size
TC540250	Water Pump Groove Joint Pliers 250mm
TC550230	Pincer/End-cutting Pliers 230mm
TC560254	Water Pump Box Joint Pliers 254mm
TC570170	Locking Curved Jaw Pliers 170mm
TC570254	Locking Curved Jaw Pliers 254mm
TC599254	Heavy Duty Fencing Pliers 254mm
TC599300	Heavy Duty Fencing Pliers 300mm

C45 Steel



- » Circlip Pliers / 5 Notch lock 45mm
- » Industrial / hardened cutting edge
- » Industrial pliers / 7 Notch lock 38mm
- » Industrial / Hardened jaw

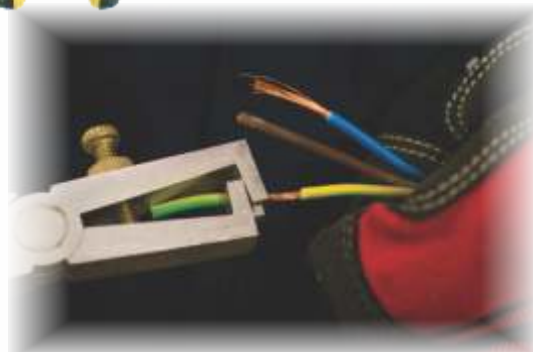

Circlip Pliers

C45 Steel



Part No.	Size
TC581170	Straight Internal Pliers 170mm
TC582170	Bent Internal Pliers 170mm
TC583170	Straight External Pliers 170mm
TC584170	Bent External Pliers 170mm



Mini Pliers

Contractor
C55 Steel



Part No.	Size
TC591120	Mini Combination Plier 120mm
TC592120	Mini Long Nose Plier 120mm
TC593120	Mini Side Cutter Plier 120mm
TC594120	Mini Round Nose Plier 120mm

Part No.	Size
TC595120	Mini Bent Nose Plier 120mm
TC596120	Mini Flat Nose Plier 120mm
TC597120	Mini Needle Nose Plier 120mm
TC598120	Mini End Cutting Plier 120mm



Axes

Part No.	Size
TC610800	800G Axe w/Fibreglass Handle 350mm
TC611800	1.8KG Axe w/Fibreglass Handle 860mm

- Features;
- » PP coated fibreglass handle
 - » Handle/Head epoxy resin & safety fastened
 - » Heat treated carbon steel head
 - » Tempered striking face
 - » TPR Grip absorbs shock



Part No. TC603005 5 Pce Mini Plier Set with Carry Bag

- Includes;
- » 1 x 120mm Mini Side Cutter TC593120
 - » 1 x 120mm Mini Combination Plier TC591120
 - » 1 x 120mm Mini Long Nose Plier TC592120
 - » 1 x 120mm Mini Round Nose Plier TC594120
 - » 1 x 120mm Mini End Cutting Plier TC598120

Spring Loaded



Pipe Wrenches

Part No.	Size
TC602300	Heavy Duty Pipe Wrench 300mm
TC602300-01	Replacement Jaw Set for TC602300
TC602350	Heavy Duty Pipe Wrench 350mm
TC602350-01	Replacement Jaw Set for TC602350
TC602450	Heavy Duty Pipe Wrench 450mm
TC602450-01	Replacement Jaw Set for TC602450
TC602600	Heavy Duty Pipe Wrench 600mm
TC602600-01	Replacement Jaw Set for TC602600



Bolt Cutters

Part No.	Size
TC601350	Bolt Cutter 350mm
TC601450	Bolt Cutter 450mm
TC601600	Bolt Cutter 600mm
TC601750	Bolt Cutter 750mm
TC601900	Bolt Cutter 900mm



Vice Jaws - Magnetic Aluminium

Part No.	Size
TCMG8100	2 Pce Prism Face 100mm x 32mm (4")
TCMG8125	2 Pce Prism Face 125mm x 32mm (5")
TCMG8150	2 Pce Prism Face 150mm x 32mm (6")
TCMG8200	2 Pce Prism Face 200mm x 32mm (8")
TCMG9100	2 Pce Rubber Face 100mm x 32mm (4")
TCMG9125	2 Pce Rubber Face 125mm x 32mm (5")
TCMG9150	2 Pce Rubber Face 150mm x 32mm (6")
TCMG9200	2 Pce Rubber Face 200mm x 32mm (8")



Protect your work pieces
Fits most vices

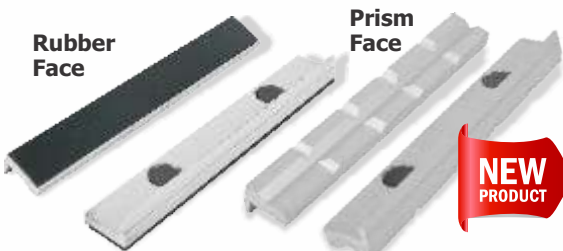

Hammers



Part No.	Size
TC604450	Claw Hammer 450G (16oz) fibreglass handle 295mm & full polished head
TC604570	Claw Hammer 570G (20oz) fibreglass handle 295mm & full polished head
TC604700	Claw Hammer 700G (24oz) fibreglass handle 295mm & full polished head
TC605450	Claw Hammer 450G (16oz) wooden handle 280mm & full polished head
TC605570	Claw Hammer 570G (20oz) wooden handle 280mm & full polished head
TC605700	Claw Hammer 700G (24oz) wooden handle 280mm & full polished head
TC606450	Claw Hammer 450G (16oz) all steel w/ergonomic grip & full polished head
TC606570	Claw Hammer 570G (20oz) all steel w/ergonomic grip & full polished head
TC606700	Claw Hammer 700G (24oz) all steel w/ergonomic grip & full polished head
TC607450	Ball Pein Hammer 450G (16oz) fibreglass handle 310mm & full polished head
TC607700	Ball Pein Hammer 700G (24oz) fibreglass handle 310mm & full polished head
TC607900	Ball Pein Hammer 900G (32oz) fibreglass handle 310mm & full polished head
TC608011	Club Hammer 1.1KG (2.5lb) fibreglass handle 215mm
TC608018	Club Hammer 1.8KG (4lb) fibreglass handle 220mm
TC609036	Sledge Hammer 3.6KG (8lb) fibreglass handle 900mm
TC609045	Sledge Hammer 4.5KG (10lb) fibreglass handle 900mm
TC609063	Sledge Hammer 5.4KG (12lb) fibreglass handle 900mm
TC612450	Mason Hammer 450G (16oz) fibreglass handle
TC612700	Mason Hammer 700G (24oz) fibreglass handle
TC613450	Rubber Mallet Hammer 450mm (16oz) fibreglass handle
TC613900	Nylon Installing Mallet Hammer 35mm fibreglass handle
TC613950	Replacement white nylon hammer heads
TC613951	Installing hammer replacement head 35mm Copper
TC613952	Installing hammer replacement head 35mm Brass
TC61400	Dead Blow Hammer 1.3KG (3LB) Black
TC615100	Machinist Hammer 1.0KG Fibreglass 370mm Handle
TC615300	Machinist Hammer 300G Fibreglass 320mm Handle
TC615500	Machinist Hammer 500G Fibreglass 340mm Handle
TC616750	Chipping Hammer 750G Fibreglass 335mm Handle
TC616750-01	Chipper Hammer replacement blade double-sided carbon steel

Sledge Hammer

**TC609036
TC609045
TC609063**

Features;

- » PP coated fibreglass handle
- » Handle/Head tapered slip-on
- » Heat treated carbon steel head
- » Tempered striking face
- » TPR Grip absorbs shock

Machinist Hammer

**TC615100
TC615300
TC615500**

Features;

- » Beveled square striking face
- » Taper peen for splitting applications
- » Fibreglass handle for durability

Chipping Hammer

**TC616750
TC616750-1**

Features;

- » Single-sided mason chipping
- » Typically used for cleaning, dressing & shaping brick & stonework
- » Slot for holding replaceable double-sided Scutch/chipping comb
- » Fibreglass handle for durability

Claw Hammer

**TC604450
TC604570
TC604700**

Features;

- » PP coated fibreglass handle
- » Fully polished head
- » TPR Grip absorbs shock
- » Heat treated carbon steel head
- » Tempered striking face & nail puller
- » Handle/Head epoxy resin fastened

Claw Hammer

**TC605450
TC605570
TC605700**

Features;

- » Hard wood handle
- » TPR Grip absorbs shock
- » Fully polished head
- » Heat treated carbon steel head
- » Handle and head steel wedged fastened
- » Tempered striking face & nail puller

Claw Hammer

**TC606450
TC606570
TC606700**

Features;

- » Fully polished head
- » Medium carbon steel grade handle
- » Handle/Head solid 1-piece
- » Heat treated carbon steel head
- » Tempered striking face & nail puller
- » TPR Grip absorbs shock

Ball Pein Hammer

**TC607450
TC607700
TC607900**

Features;

- » PP coated fibreglass handle
- » Handle/Head epoxy resin & safety fastened
- » Heat treated carbon steel head
- » Tempered striking face
- » TPR Grip absorbs shock
- » Fully polished head

Club Hammer

**TC608011
TC608018**

Features;

- » PP coated fibreglass handle
- » TPR Grip absorbs shock
- » Heat treated carbon steel head
- » Tempered striking face & nail puller
- » Handle/Head epoxy resin fastened

Mason Hammer

**TC612450
TC612700**

Features;

- » PP coated fibreglass handle
- » Handle/Head epoxy resin & safety fastened
- » Heat treated carbon steel head
- » Tempered striking face & nail puller
- » TPR Grip absorbs shock

Rubber Mallet

TC613450

Features;

- » Non-marring
- » PP coated fibreglass handle
- » Handle/Head epoxy resin & safety fastened
- » Rubber head
- » TPR Grip absorbs shock

Nylon Mallet

TC613900

Features;

- » PP coated fibreglass handle
- » Handle/Head epoxy resin & safety fastened
- » Chrome plated steel & nylon head
- » TPR Grip absorbs shock

Interchangeable Heads!

Nylon  **Brass** 

Copper 

Hand Saws

**NEW
PRODUCT**



Part No.	Size
TCSAW001	450mm Hand Saw 7tpi 0.9mm w/tempered blade & ABS handle
TCSAW002	550mm Hand Saw 7tpi 0.9mm w/tempered blade & ABS handle
TCSAW005	550mm Hand Saw 7tpi 0.9mm w/tempered blade & ABS handle
TCSAW010	300mm Back Saw 12tpi 0.7mm w/tempered blade & ABS handle
TCSAW011	Back Saw Mitre Box Set Multi-angle 300mm
TCSAW012	150mm Job Saw 7tpi w/tempered blade & ABS handle
TCSAW020	3pc Saw Set w/Hand Saw, Back Saw & Job Saw (Blister)
TCSAW021	3pc Saw Set w/Hand Saw, Back Saw & Job Saw (Nylon bag)



**Hand Saw
TCSAW001**

- Features;**
- » Special tooth design for ripping & crosscut applications
 - » Suitable for cutting both hard & soft wood and plastic
 - » Ideal for quick & rough cutting



**Hand Saw
TCSAW002**

- Features;**
- » Special tooth design for ripping & crosscut applications
 - » Suitable for cutting both hard & soft wood and plastic
 - » Ideal for quick & rough cutting



**Hand Saw
TCSAW005**

- Features;**
- » Special tooth design for ripping & crosscut applications
 - » Suitable for cutting both hard & soft wood and plastic
 - » Ideal for quick & rough cutting



**Back Saw
TCSAW010**

- Features;**
- » Ideal for crosscut applications in wood
 - » This stiff blade allows for better control and finer wood working
 - » Ideal for cutting mitres and tennon joints



**Back Mitre Saw
TCSAW011**

- Features;**
- » Multi-angle



**Job Saw
TCSAW012**

- Features;**
- » Great for usage around the home and garden or construction site. Also suitable for drywall
 - » Ideal for most small wood sawing applications
 - » Ideal for quick & rough cutting

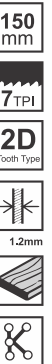

**TCSAW020 : 3 Pce Set in blister
Contains a Hand Saw, Job Saw & Back Saw**

- Features;**
- » Ideal for ripping & crosscut applications
 - » Suitable for both hard & soft wood
 - » Ideal for quick & rough cutting



Hand Saw:

**450
mm**

Back Saw:

**300
mm**

Job Saw:

**150
mm**



**TCSAW021 : 3 Pce Set in Nylon bag
Contains a Hand Saw, Job Saw & Back Saw**

- Features;**
- » Ideal for ripping & crosscut applications
 - » Suitable for both hard & soft wood
 - » Ideal for quick & rough cutting

Cantilever Tool Boxes

Part No. TCTB088

88 Pce Cantilever Tradesman Tool Set

» 468 x 218 x 203mm

Contents;

- » Chrome vanadium for long life
- » 5 Tray storage space
- » Double handle for carrying & opening
- » Lockable
- » Steel construction

NEW
PRODUCT



Construction Industrial Automotive Engineering

Part No. TCTB001

5 Tray Cantilever Tool Box

» Empty

» 468 x 218 x 203mm

» Double handle for carrying & opening

» Lockable

» Steel construction

NEW
PRODUCT



Part No. TCTB168

168 Pce Cantilever Mechanics Tool Set

» 470 x 220 x 230mm

Contents;

- » Chrome vanadium for long life
- » 5 Tray storage space
- » Double handle for carrying & opening
- » Lockable
- » Steel construction

NEW
PRODUCT



Construction Industrial Automotive Engineering

Set includes;

- » 18 x 1/2" Dr. Sockets Sizes 10 - 32mm
- » 1/2" Dr. 72 Teeth Quick release ratchet handle
- » 1/2" Dr. x 5" Extension bar
- » 1/2" Dr. x 10" Extension bar w/3-way adaptor
- » 1/2" Dr. Universal joint
- » 12 x 1/4" Dr. Socket 4 - 13mm
- » 1/4" Dr. 72 Teeth Quick release Ratchet handle
- » 1/2" Dr. x 3" Extension bar
- » 6 x 1/4" Socket bits
- » Screwdriver handle
- » 6" Long nose plier
- » 7" Combination plier
- » 3m Measuring tape
- » Zinc alloy cutter
- » 10 x Blades
- » 5 x Screwdrivers
- » 9.5" Water pump plier
- » 9 x Hex Keys 1.5 - 10mm
- » 12 x Spanners 6 - 19mm
- » 6" Side cutting plier
- » 300g Machinist hammer
- » 300mm Hacksaw
- » Long nose plier



TCTB088



TCTB168

Set includes;

- » 13 x 1/4" Dr. Sockets Sizes 10 - 32mm
- » 1/4" Dr. Universal joint
- » 1/4" Dr. x 3" Extension bar
- » 1/4" Adapter
- » 1/2" Dr. 72 Teeth Quick release ratchet handle
- » 10 x 3/8" Dr. Sockets 10 - 19mm
- » 10 x 3/8" Dr. Deep Sockets 10 - 19mm
- » 7 x 3/8" Socket bits T30 - T60
- » 3/8" Universal joint
- » 3/8" Dr. x 3" & 6" Extension bar
- » 3/8" Dr. 72 Teeth Quick release ratchet handle
- » 1/2" Dr. x 3", 5" & 10" Extension bar
- » 2 x 1/2" Dr. Spark plug sockets 16 - 21mm
- » 1/2" Dr. Universal joint
- » 1/2" Dr. x 10" Sliding bar
- » 5 x Screwdrivers
- » 60 x 25mm Bits
- » Screwdriver handle
- » 9 x Hex Keys 1.5 - 10mm
- » 10" Water pump plier
- » 10" Lock plier
- » 6" Diagonal plier
- » 6" Long nose plier
- » 7" Combination plier
- » 2 x Punches
- » 12oz. Hammer with ball head
- » 10" Adjustable wrench
- » 13 x Combination wrenches 6 - 22mm
- » Metal case 470 x 220 x 230mm

TCTB001



TCTB088

TCTB168

Tool Trolleys

Part No. TC620040

6 Drawer Roller Cabinet on Castors

Empty - no tools included



Features;

- » Trolley Size : 780 x 465 x 970mm
- » Drawers : 3 x Small 545 x 395 x 45mm
3 x Medium 545 x 395 x 125mm
- » Anti-shock protection on all four corners
- » Integrated ergonomic handle within the worktop
- » Central locking with two reversible keys providing security
- » Full extension ball bearing drawer sides open & close easily
- » Optimised storage, compatible with the modular storage system
- » Drawer release mechanism incorporated within the handle

Part No. TC620030

6 Drawer Roller Cabinet on Castors

Includes 196 Pce of Stock in 15 Tool Modules



Features;

- » Trolley Size : 780 x 465 x 970mm
- » Drawers : 3 x Small 545 x 395 x 45mm
3 x Medium 545 x 395 x 125mm
- » Anti-shock protection on all four corners
- » Integrated ergonomic handle within the worktop
- » Central locking with two reversible keys providing security
- » Full extension ball bearing drawer sides open & close easily
- » Optimised storage, compatible with the modular storage system
- » Drawer release mechanism incorporated within the handle



Torque Wrenches - Digital

Part No.	Description
TCTQ12135	1/2" x 6.75 - 135NM 2% Acc. 0.01 Res. 36 x Gear
TCTQ12200	1/2" x 10 - 200NM 2% Acc. 0.01 Res. 36 x Gear
TCTQ12340	1/2" x 17 - 340NM 2% Acc. 0.01 Res. 36 x Gear
TCTQ14030	1/4" x 1.5 - 30NM 20% Acc. 0.01 Res 36 x Gear
TCTQ34500	3/4" x 25 - 500NM 2.5% Acc. 0.01 Res. 48 x Gear
TCTQ38060	3/8" x 2.0 - 60NM 2% Acc. 0.01 Res. 36 x Gear
TCTQ38135	3/8" x 6.75 - 135NM 2% Acc. 0.01 Res. 36 x Gear

**NEW
PRODUCT**



Torque Wrenches - Mechanical

Part No.	Description
TCTQ1425-01	1/4" x 5 - 25NM
TCTQ3830-01	3/8" x 5 - 30NM
TCTQ3860-01	3/8" x 5 - 60NM
TCTQ12110-01	1/2" x 10 - 110NM
TCTQ12210-01	1/2" x 20 - 210NM
TCTQ12350-01	1/2" x 65 - 350NM
TCTQ12400-01	1/2" x 70 - 400NM

**NEW
PRODUCT**



Hacksaw Blades

100/Pack	2pc Carded	Description
TC925018	TC925018-2	Bi-Metal 14T x 300mm
TC925019	TC925019-2	Bi-Metal 18T x 300mm
TC925020	TC925020-2	Bi-Metal 24T x 300mm
TC925021	TC925021-2	Bi-Metal 32T x 300mm

Part No.	Description
TC925002	Junior Hacksaw Blade 150mm for TCHS003
TC925004	Carbon Steel 14T x 300mm
TC925005	Carbon Steel 18T x 300mm
TC925006	Carbon Steel 24T x 300mm
TC925007	Carbon Steel 32T x 300mm



Hacksaws

Part No.	Description
TCHS001	Aluminum Alloy Hacksaw Frame 300mm C/w Flexible Double Edge Blade
TCHS002	Aluminum Alloy Hacksaw Frame 300m C/w 1 + 3 Free Blades Tork Craft
TCHS003	Aluminium Alloy Junior Hacksaw Frame 150mm
TCHS004	Hacksaw Combo Set 1 x TCHS002 + 1 x TCHS003



- Unique frame shape and ergonomic handle design
- 2 choices of angles - allows both straight and angled cutting 45° & 90°
- With a 300mm flexible double-sided hacksaw blade, one side carbon steel 24tpi and one side wood 8tpi
- Frame can accommodate most standard 12mm and 25mm double-sided blades
- Designed for cutting steel pipe, PVC, ABS, Wood, Drywall, Styrofoam & other materials



- Unique frame shape and ergonomic handle design
- Unique blade storing compartment within handle - stores up to 6 spare blades.
- 2 choices of angles - allows both straight and angled cutting 90° & 180°
- With a 300mm flexible single sided carbon steel 24tpi
- Designed for cutting steel pipe, PVC, ABS, Wood, Drywall, Styrofoam & other materials



TCHS004
Combo of
TCHS002 + TCHS003



Pipe Cutter



» Cuts Brass, Copper & Steel pipe

Part No.	Size
TC PC330	3 - 30mm
TC PC635	6 - 35mm
TC PC642	6 - 42mm
TCPC001	Spare Blades



TC PC330

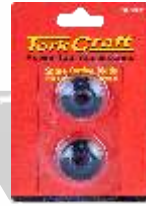

TCPC001



TC PC635



TC PC642

Part No.	Description
TC PC330GC	Giracut Pipe & Tube Cutter 3 - 30mm
TC PC001GC	Giracut Spare Blades for Pipe Cutter

NEW PRODUCT



Fast Cut



Free cutting blade storage



Lock & Unlock

Gear system automatically tightens as wound



Ruler used as handle

- » Fast cutting handle gear design allows for cutting faster than most regular pipe cutters
- » Equipped with a 100mm steel ruler
- » Fold away de-burring tool
- » HSS cutting blade & FREE replacement blade stored in handle



Bottled Water

PART NO. WATER500
Premium Still Water
Bottled 500ml
with TORK CRAFT & other logos



Lanyard

PART NO. TC LANYARD
Vermont Sales Lanyard with logos

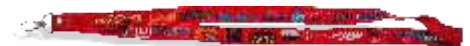

Vermont Caps

- » One size fits all
- » Colours may vary



TC00119



TC00109



TC00118



TC00108

Part No.	Description
TC00108	TorkCraft Baseball Cap Blue with Torkcraft logo embroidery
TC00109	TorkCraft Baseball Cap Red with TorkCraft logo embroidery
TC00118	TorkCraft Baseball Cap Grey with TorkCraft logo embroidery
TC00119	TorkCraft Bucket Hat Grey with TorkCraft logo embroidery
TC00128	TorkCraft Baseball Cap Blue with 5 LED Lights and embroidery
TC00408	TorkCraft Baseball Cap White with embroidery
TC00107	TorkCraft Beanie Red
TC00138	TorkCraft Beanie Black



TC00408



TC00138



TC00107

Vermont Mens Shirts

- » 2-Tone Stone/Khaki Bush Shirt 100% Cotton with TorkCraft & other logo embroidery
- » Stone-washed Denim Shirts 100% Cotton with TorkCraft & other logo embroidery
- » 100% Cotton with TorkCraft & other logo embroidery
- » Colours may vary



Size	2-Tone Khaki	Stone washed Denim	Golf Red/White	White	Navy	Red
Small	TC00110	TC00120	TC00101	TC00801	TC00401	TC00901
Medium	TC00111	TC00121	TC00102	TC00802	TC00402	TC00902
Large	TC00112	TC00122	TC00103	TC00803	TC00403	TC00903
X-Large	TC00113	TC00123	TC00104	TC00804	TC00404	TC00904
2X-Large	TC00114	TC00124	TC00105	TC00805	TC00405	TC00905
3X-Large	TC00115	TC00125	TC00106		TC00406	TC00906
4X-Large	TC00136		TC01117		TC00407	TC00907
5X-Large			TC01118			

Vermont Ladies Shirts



Size	White	Olive	Khaki	Navy	Red	Golf Red/White
Small	TC00501	TC00601	TC00701	TC00607	TC00612	TC00307
Medium	TC00502	TC00602	TC00702	TC00608	TC00613	TC00308
Large	TC00503	TC00603	TC00703	TC00609	TC00614	TC00309
X-Large	TC00504	TC00604	TC00704	TC00610	TC00615	TC00310
XX-Large	TC00505	TC00605	TC00705	TC00611	TC00616	TC00311
XXX-Large	TC00506	TC00606	TC00706	TC00617	TC00618	

Unisex T-shirt Range

- » T-shirt 180g Cotton with screen printed logos on front and back - Colours may vary

T-shirts	Black	White
Small	TC00130	TC00170
Medium	TC00131	TC00171
Large	TC00132	TC00172
X-Large	TC00133	TC00173
XX-Large	TC00134	TC00174



Cycling Kit

Size	Male	Female	Children
XXX-Small			TC00180
XX-Small			TC00181
X-Small		TC00160	TC00182
Small	TC00150	TC00161	TC00183
Medium	TC00151	TC00162	TC00184
Large	TC00152	TC00163	TC00185
X-Large	TC00153	TC00164	TC00186
2 X-Large	TC00154		TC00187

Jackets Unisex Range

Size	3-in-1 Ski Jacket	Soft Shell Jacket
Small	TC01001	TC026001
Medium	TC01002	TC026002
Large	TC01003	TC026003
X-Large	TC01004	TC026004
2 X-Large	TC01005	TC026005
3 X-Large	TC01006	TC026006

Soft Shell Jackets w/TorkCraft & other logos embroidered

- » Waterproof
- » Windproof
- » Adjustable velcro closure at cuffs
- » 2 Hand pockets with zips
- » 1 Breast pocket with zip
- » 2 Interior pockets
- » Elastic cord w/stoppers in bottom hem
- » Hanging loop



TC026001



TC01001



3-in-1 Ski Jackets w/TorkCraft & other logos embroidered

- » Two layer jacket, top layer can be removed
- » Wind & rain proof zip
- » Zip up side pockets
- » Zip up breast pocket
- » Fold-away hoodie
- » Hook & loop elements flap over main zip
- » Hook & loop cuffs to prevent wind
- » Removeable inner fleece
- » Hanging loop

Unisex Hoody's

Size	Part No.	Colour
Small	TC027301	Grey
Medium	TC027302	Grey
Large	TC027303	Grey
X-Large	TC027304	Grey
2 X-Large	TC027305	Grey
3 X-Large	TC027306	Grey
4 X-Large	TC027307	Grey

- » Grey hoody with TorkCraft embroidery
- » Unisex
- » Colours may vary



Bufs - Headwear



Outdoor Sport Fishing

Part No. TCBUF001

- BUFF : Multi-functional Seamless Headwear**
- » One size fits all
 - » Can we worn 12 different ways
 - » 100% Polyester Microfiber
 - » Comfortable to wear

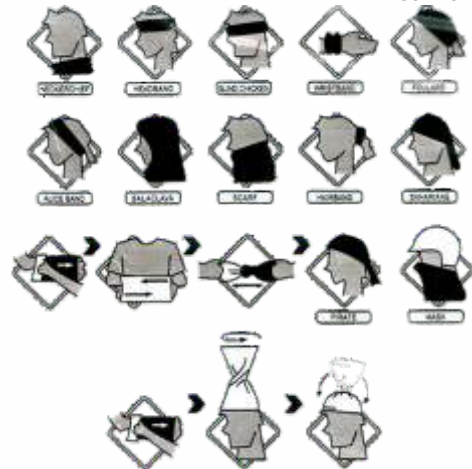

- Uses;**
- Neckerchief
 - Headband
 - Wristband
 - Mask
 - Hair-band
 - Balaclava
 - Scarf
 - Scrunchie
 - Beanie
 - Saharaine
 - Pirate cap
 - Bandana

Genuine TorkCraft Vellies



Men's

Size	Part No.	Colour
Size 6	TC01201	Brown
Size 7	TC01202	Brown
Size 8	TC01203	Brown
Size 9	TC01204	Brown
Size 10	TC01205	Brown
Size 11	TC01206	Brown
Size 12	TC01207	Brown
Size 13	TC01208	Brown
Size 14	TC01209	Brown
Size 15	TC01210	Brown

Ladies

Size	Part No.	Colour
Size 3	TC01301	Brown
Size 4	TC01302	Brown
Size 5	TC01303	Brown
Size 6	TC01304	Brown
Size 7	TC01305	Brown
Size 8	TC01306	Brown

NEW PRODUCT



NEW PRODUCT

Display Stands (Stock not incl.)



Stand 24
115mm Cutting Disc
Holder for pegboard



Stand 25
230mm Cutting Disc
Holder for pegboard



MER 033
50 Slot Rotary Burr
Counter Display
345 x 220 x 145mm - Empty



MER018
TorkCraft Diamond Blade
Counter Top Stand Bulk
2 x 115mm & 1 x 230mm



MER019
Pinnacle Diamond Blade
Counter Top Stand Bulk
2 x 115mm & 1 x 230mm



MER SPECIALS BASKET
Specials Basket
500 x 500 x 900mm
Empty



MER 035
Professional Series
Diamond Blade Stand - Empty
Holds 115mm & 230mm Blades



MER 027
12pc Clip Strip
720 x 350mm
(grey) - Empty



MER 026
Hacksaw Blade Display Stand
Empty, stock not included
Fits counter & stand

MER 040
Eyewear Display 730 x
412 x 70mm - Empty



Display Stands (Stock not incl.)



MER 034
Grinding Counter
Top Display Stand
500 x 155 x 170mm - Empty



MER 300
A-Frame Cutting Disc Floor Display
on castors Black
1860 x 760 x 380mm Empty



MER ABRASIVE STAND
Abrasive Floor Shelf Stand
1820 x 980 x 290mm Empty

**Stands subject to availability.
Headers and pegs not included.
Can take up to 8 to 12 weeks to order.**

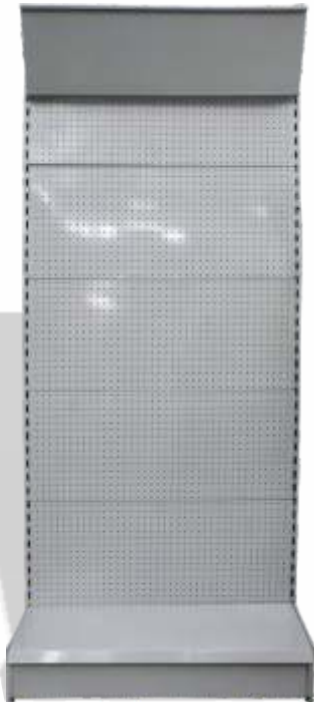

MER003
Flat Stand 1000 x 2200 x 350mm
Imported - Grey - Empty



MER004
Light Box Stand 1000 x 2200 x 350mm
Imported - Grey - Empty



MER 600
Blade Cross Bar System
(2 Bars & 4 Blade Holders)
China Stand / Empty



MER002
Stand 1000 x 1400 x 350mm
Imported - Grey - Empty



MER016
Corner Stand 2200mm

Stand 16
Abrasive Basket
1000mm x 350mm



Stand 17
Abrasive Basket
Divider



Create & Learn Wooden Toys

Part No.	Description
TCTY1002	56 Pce Sidewalk Chalk Art in Bucket
TCTY1052	Wooden Birdhouse
TCTY1053	Wooden Pull-back Sports Car
TCTY1056	Wooden Aeroplane
TCTY4218	Wooden Train Head
TCTY4385	Wooden Picture Frame
TCTY4386	Wooden Pirate Ship

- » Create memories with your children while they learn
- » Each set includes the wood pieces and hardware to complete the project
- » Each set includes stickers to decorate your creation
- » Additional tools required that are not included

- Hammer
- Safety glasses
- Tape measure
- Paint



TCTY1002

- » Create memories with your children while they learn
- » Features sidewalk chalk for your budding urban artist!
- » From hopscotch to graffiti - transform city surfaces into art & fun.
- » Non toxic dies

- » Contents;
 - 44 x Chalk pieces
 - 4 x Chalk holders
 - 1 x Chalk brush
 - 6 x Stencils
 - 1 x Bucket container



TCTY1052



TCTY1053



TCTY1056



TCTY4218



TCTY4385



TCTY4386



What is your dream project?

***Build your dream project
with Tork Craft tools and
power tool accessories***



Vermont Sales

SOUTH AFRICA'S #1 SUPPLIER (Pty) Ltd
of power tool accessories



*Bringing you brands
from around the world...*



*TorkCraft is a registered trademark.
All rights reserved*

YOUR AUTHORISED DEALER

